



### FEATURES

- 1200W output power
- 80 PLUS® Platinum efficiency
- 12V main output
- 3.3V and 5V standby output
- 1U height: 2.15" x 12.65" x 1.57"
- 28 Watts per cubic inch density
- N+1 redundancy capable, including hot plugging (up to 8 in parallel)
- Active current sharing on 12V main output; ORing FET
- Overvoltage, overcurrent, overtemperature protection
- Internal cooling fan (variable speed)
- PMBus™ / I<sup>2</sup>C interface with status indicators
- RoHS compliant

### PRODUCT OVERVIEW

The D1U54P-W-1200-12-HxxxC series are 80 PLUS® Platinum efficiency 1200 watt, power factor corrected front end supplies with a 12V main output and a 3.3V (3A) or 5V (3A) standby. They have active current sharing and up to 8 supplies may be operated in parallel. The supplies may be hot plugged, they recover from overtemperature faults, and have status LEDs on their front panel in addition to logic and PMBus™ status signals. Their low profile 1U package and >28W/cubic inch power density make them ideal for delivering reliable, efficient power to servers, workstations, storage systems and other 12V distributed power systems.

### ORDERING GUIDE

Part Number	Power Output High Line AC	Power Output Low Line AC	Main Output	Standby Output	Airflow
D1U54P-W-1200-12-HC4PC	1200W	1100W	12Vdc	3.3Vdc	Back to front
D1U54P-W-1200-12-HA4PC				5Vdc	
D1U54P-W-1200-12-HC3PC				3.3Vdc	Front to back
D1U54P-W-1200-12-HA3PC				5Vdc	

<sup>1</sup> Refer to page 5 for alternate connector pinout assignment (HxxC).

<sup>2</sup> Refer to page 7 for alternate input connector (HxxxKC).

<sup>3</sup> The HCxxC variants are certified for compliance to 80 PLUS® Platinum efficiency requirements.

### INPUT CHARACTERISTICS

Parameter	Conditions	Min.	Nom.	Max.	Units
Input Voltage Operating Range		90	115/230	264	Vac
Input Frequency		47	50/60	63	Hz
Turn-on Input Voltage	Ramp up	80	85	89	Vac
Turn-off Input Voltage	Ramp down	65	73	78	
Maximum current at Vin = 100Vac	1100W			12	Arms
Inrush Current	Cold start between 0 to 200msec			25	Apk
Power Factor	At 230Vac, full load		0.99		
Efficiency (230Vac) excluding fan load	20% load	90			%
	50% load	94			
	100% load	91			

### OUTPUT VOLTAGE CHARACTERISTICS

Output Voltage	Parameter	Conditions	Min.	Typ.	Max.	Units
12V	Voltage Set Point	50% load		12		Vdc
	Line and Load Regulation		11.64		12.36	
	Ripple Voltage & Noise <sup>4</sup>	20MHz Bandwidth			150	mV p-p
	Output Current (230Vac)		5		100	A
	Output Current (120Vac)		5		90	
	Load Capacitance		0		30,000	µF
3.3VSB	Voltage Set Point			3.3		Vdc
	Line and Load Regulation		3.14		3.46	
	Ripple Voltage & Noise <sup>4</sup>	20MHz Bandwidth			75	mV p-p
	Output Current		0		3	A
	Load Capacitance		0		1000	
	5VSB	Voltage Set Point				
Line and Load Regulation			4.76	5.0	5.24	
Ripple Voltage & Noise <sup>4</sup>		20MHz Bandwidth			75	mV p-p
Output Current			0		3	A
Load Capacitance			0		1000	

<sup>4</sup> Ripple and noise are measured with 0.1 µF of ceramic capacitance and 10 µF of tantalum capacitance on each of the power supply outputs. A short coaxial cable with 50Ω scope termination is used.



Available now at  
[www.murata-ps.com/en/3d/acdc.html](http://www.murata-ps.com/en/3d/acdc.html)



OUTPUT CHARACTERISTICS					
Parameter	Conditions	Min.	Typ.	Max.	Units
Startup Time	AC ramp up			3	s
Transient Response	12V, 50% load step, 1A/μs di/dt			600	mV
	3.3VSB, 50% load step, 1A/μs di/dt			165	
Current sharing accuracy (up to 8 in parallel)	At 100% load			±7	%
Hot Swap Transients	All outputs remain in regulation			5	%
Holdup Time	100% load	12			ms

ENVIRONMENTAL CHARACTERISTICS					
Parameter	Conditions	Min.	Typ.	Max.	Units
Storage Temperature Range		-40		70	°C
Operating Temperature Range		0		60	
Operating Humidity	Noncondensing	5		90	%
Storage Humidity		5		95	
Altitude (without derating at 40°C)		3000			m
Shock	30G non operating				
Operational Vibration	Sine sweep; 5-150Hz, 2G; random vibration, 5-500Hz, 1.11G				
MTBF	Per Telcordia SR-332 M1C1 @40°C	529K			hrs
Safety Approvals	CAN/CSA C22.2 No UL 60950-1-2011, 2nd Ed. UL 60950-1, 2nd Ed. IEC60950-1:2005 (2nd Ed.) w A1:2009, EN 60950-1:2006+A11:2009 +A1:2010 +A12:2011			60950-1-07, 2nd Ed.	Am.1:2011 Ed.
Input Fuse	Power Supply has internal 15A/250V fast blow fuse on the AC line input				
Weight	3.15 lbs (1.43 kg)				

PROTECTION CHARACTERISTICS						
Output Voltage	Parameter	Conditions	Min.	Typ.	Max.	Units
12V	Overtemperature (intake)	Autorestart	60	65	70	°C
	Overvoltage	Latching	13		14	V
	Overcurrent At 220Vac	Hiccup	105		120	A
	Overcurrent At 110Vac	Hiccup	99		117	
3.3VSB	Overvoltage	Latching	3.6		4.0	V
	Overcurrent	Hiccup	3.3		4.5	A
5VSB	Overvoltage	Latching	5.4		6.0	V
	Overcurrent	Hiccup	3.3		4.5	A

ISOLATION CHARACTERISTICS					
Parameter	Conditions	Min.	Typ.	Max.	Units
Insulation Safety Rating / Test Voltage	Input to Output - Reinforced	3000			Vrms
	Input to Chassis - Basic	1500			Vrms
Isolation	Output to Chassis	500			Vdc

STATUS INDICATORS AND CONTROL SIGNALS	GREEN	AMBER
Condition	LED Status (Power)	LED Status (Fault)
Standby - ON; Main output - OFF; AC PRESENT	Blinking green	Off
Standby - ON; Main output - ON	Solid green	Off
Main output overcurrent, undervoltage, overvoltage	Off	On
FAN_FAULT; overtemperature; standby overcurrent, undervoltage	Off	On
No AC Power	Off	Off
Power Supply Warning Event	Off	Blinking

EMISSIONS AND IMMUNITY		
Characteristic	Standard	Compliance
Input Current Harmonics	IEC/EN 61000-3-2	Complies
Voltage Fluctuation and Flicker	IEC/EN 61000-3-3	Complies
Conducted Emissions	FCC 47 CFR Part 15/CISPR 22/EN55022	Class A with 6dB margin
ESD Immunity	IEC/EN 61000-4-2	Level 4 criteria A
Radiated Field Immunity	IEC/EN 61000-4-3	Level 3 criteria B
Electrical Fast Transients/Burst Immunity	IEC/EN 61000-4-4	Level 3 criteria B
Surge Immunity	IEC/EN 61000-4-5	Level 3 criteria A
RF Conducted Immunity	IEC/EN 61000-4-6	Level 3 criteria A
Magnetic Field Immunity	IEC/EN 61000-4-8	3 A/m criteria B
Voltage Dips, Interruptions	IEC/EN 61000-4-11	230Vin, 100% load, Phase 0°, Dip 100% Duration 10ms (A) 230Vin, 50% load, Phase 0°, Dip 100% Duration 20ms (VSB:A, V1:B) 230Vin, 100% load, Phase 0°, Dip 100% Duration > 20ms (VSB, V1:B)

**DERATING CURVES**

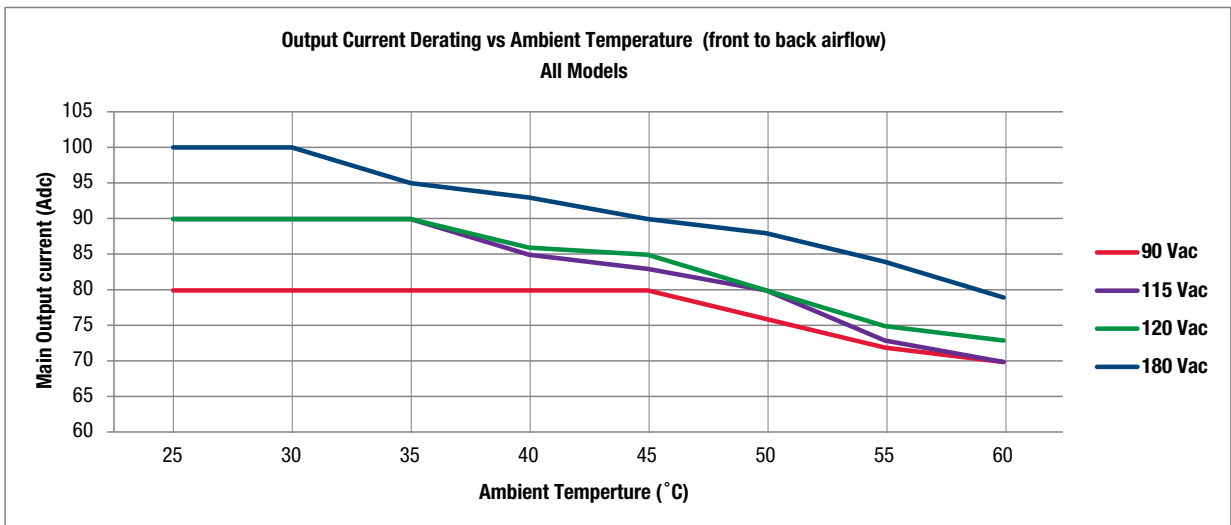
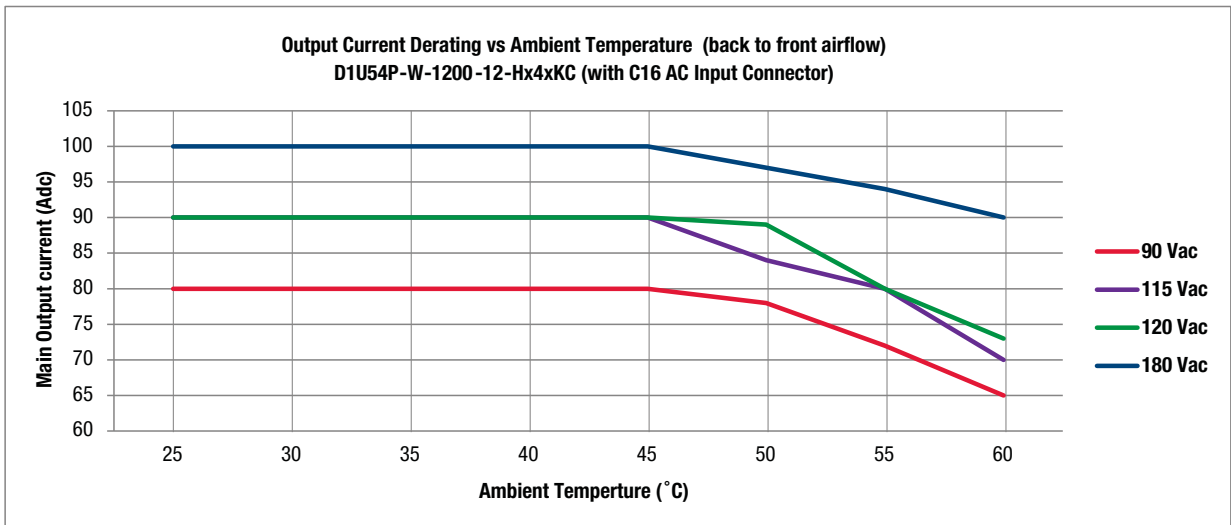
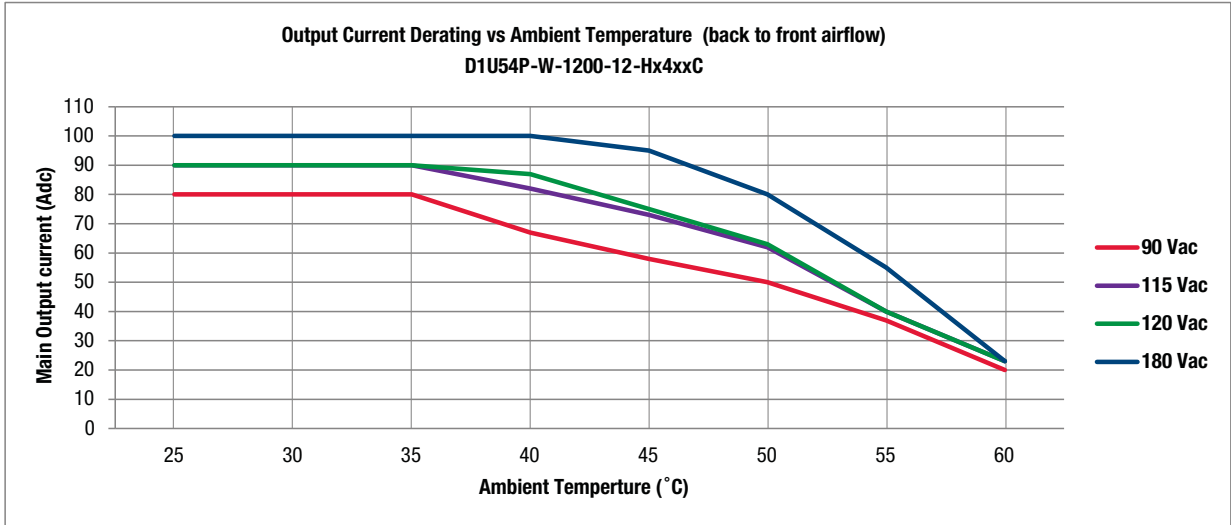

### OUTPUT CONNECTOR AND SIGNAL SPECIFICATION

E1	E2	E3	E4	E5	1	2	3	4	5	6	7	8	9	10
D1	D2	D3	D4	D5										
C1	C2	C3	C4	C5										
B1	B2	B3	B4	B5										
A1	A2	A3	A4	A5										

#### PIN ASSIGNMENTS - D1U54P-W-1200-12-HxxxPC

Tyco PN 1926734-2 (Power Supply)		
Pin	Signal Name	Comments
6, 7, 8, 9, 10	V1	+ 12V main output
1, 2, 3, 4, 5	PGND	+ 12V main output return
A1	VSB	Standby output
B1	VSB	Standby output
C1	VSB	Standby output
D1	VSB	Standby output
E1	VSB	Standby output
A2	VSB_return	Standby return
B2	VSB_return	Standby return
C2	unused	
D2	unused	
E2	unused	
A3	APS	I2C address and protocol selection, (select by a pull down resistor)
B3	unused	
C3	SDA	I2C data signal line
D3	V1_SENSE_R	- Remote Sense return
E3	V1_SENSE	+ Remote Sense
A4	SCL	I2C clock signal line
B4	PS_ON	Remote On/Off
C4	SMB_ALERT	I2C alert signal
D4	unused	
E4	ACOK	AC input OK
A5	PSKILL	Power supply kill, short pin
B5	ISHARE	Current share bus, short pin
C5	PWOK	Power OK, short pin
D5	unused	
E5	PRESENT_L	Power supply present, short pin

#### ALTERNATE PIN ASSIGNMENTS - D1U54P-W-1200-12-HxxxC

Tyco PN 1926734-4 (Power Supply)		
Pin	Signal Name	Comments
6, 7, 8, 9, 10	V1	+ 12V main output
1, 2, 3, 4, 5	PGND	+ 12V main output return
A1	VSB	Standby output
B1	VSB	Standby output
C1	VSB	Standby output
D1	VSB	Standby output
E1	VSB	Standby output
A2	VSB_return	Standby return
B2	VSB_return	Standby return
C2	unused	
D2	unused	
E2	unused	
A3	PS_KILL	Power supply kill, short pin
B3	unused	
C3	SDA	I2C data signal line, short pin
D3	V1_SENSE_R	- Remote Sense return, short pin
E3	V1_SENSE	+ Remote Sense, short pin
A4	SCL	I2C clock signal line
B4	PS_ON	Remote On/Off
C4	SMB_ALERT	I2C alert signal
D4	ISHARE	Current share bus
E4	ACOK	AC input OK
A5	A0	Address 0
B5		
C5	PWOK	Power OK
D5	A1	Address 1
E5	PRESENT_L	Power supply present

Contact Murata Sales for availability of variants with this connector configuration.

#### MATING CONNECTOR

Part Number	Description
Tyco Electronics 1926733-5	Right Angle

**WIRING DIAGRAM FOR OUTPUT**

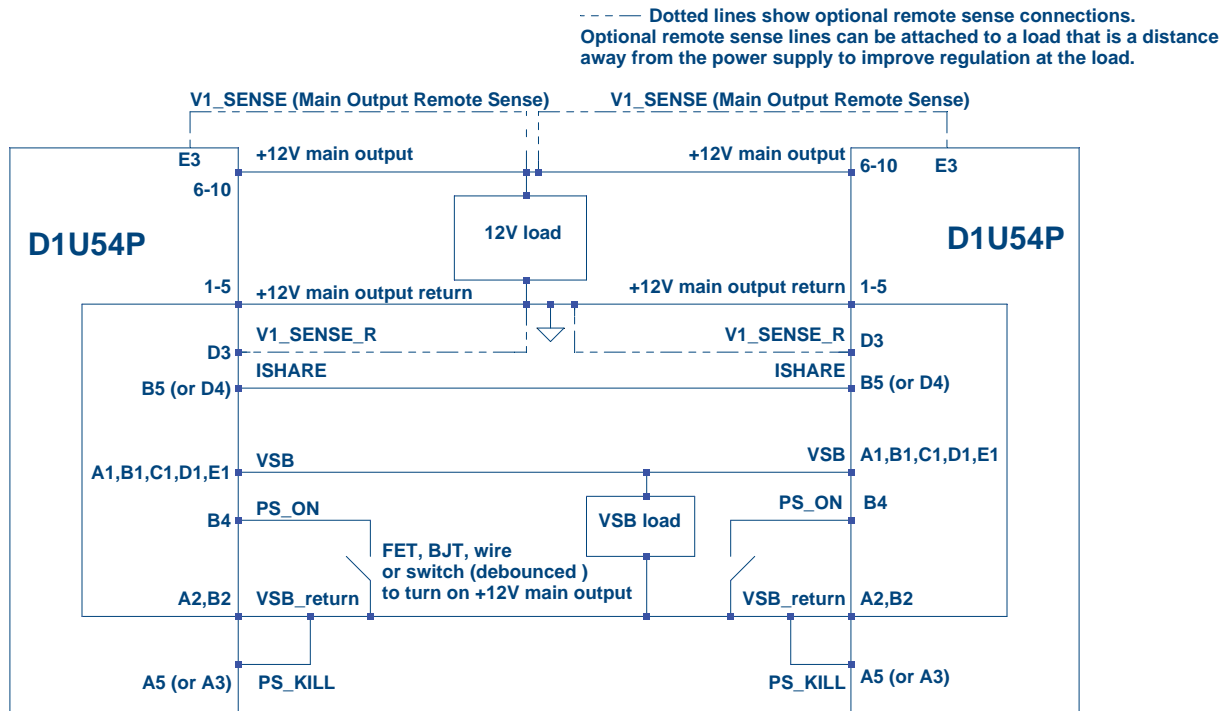

**CURRENT SHARING NOTES**

Main Output: Current sharing is achieved using the active current share method. (See wiring diagram for connection details.)

Current sharing can be achieved with or without remote sense connected to the common load.

+VSB outputs can be tied together for redundancy but total combined output power must not exceed the rated standby power. The +VSB output has internal ORing MOSFET for additional redundancy / internal short protection.

The current share pin B5 (or D4 for alternate pin out model) is a connection between the units. It is input and/or output as the voltage on the line controls the current share. A power supply will respond to a change in this voltage but a power supply can also change the voltage depending on the load drawn from it. On a single unit this would read 8V at 100% load. For two units sharing load then this should read 4V for perfect current sharing.

Up to 8 units can be paralleled together. Please consult your Murata sales representative if operation with more than 8 units in parallel is needed.

### MECHANICAL DIMENSIONS

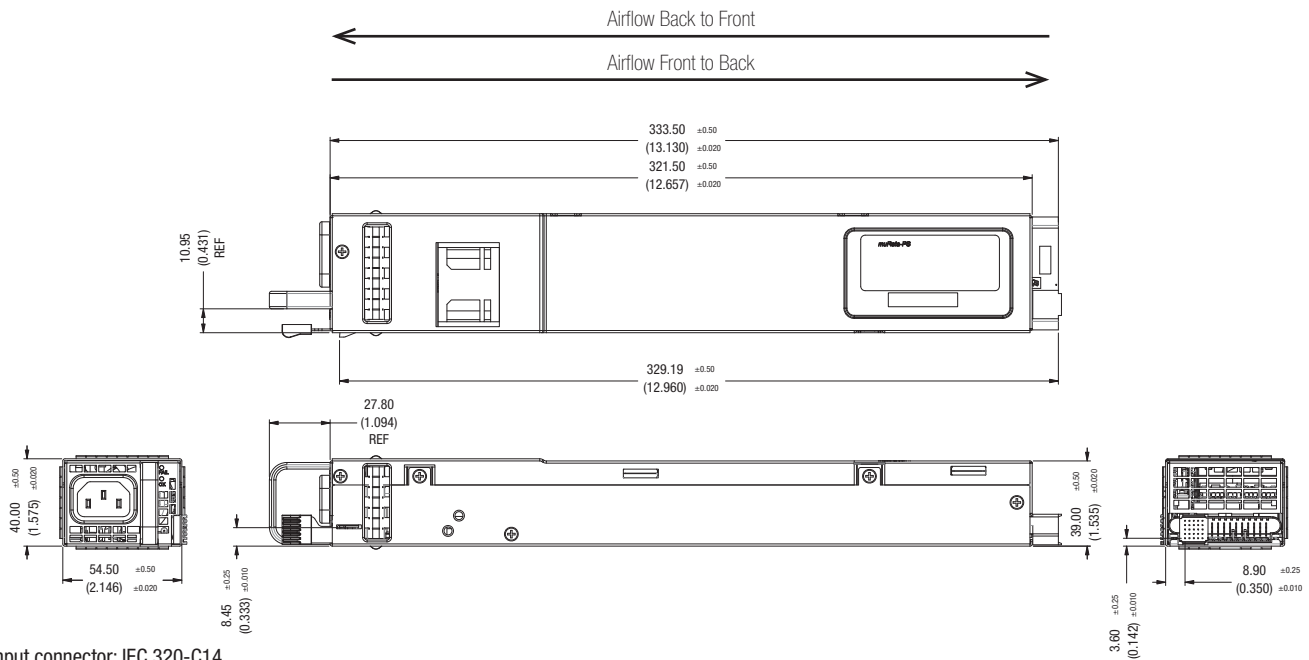

AC input connector: IEC 320-C14  
 Alternate input connector: IEC 320-C16 (for HxxxKC models)  
 Dimensions: 2.15" x 12.657" x 1.575" [54.5mm x 322.0mm x 40.0mm]

### OPTIONAL ACCESSORIES

Description	Part Number
12V D1U54P Output Connector Card	D1U54P-12-CONC

### APPLICATION NOTES

Document Number	Description	Link
ACAN-44	D1U54P Output Connector Card	<a href="http://www.murata-ps.com/data/apnotes/acan-44.pdf">www.murata-ps.com/data/apnotes/acan-44.pdf</a>
ACAN-45	D1U54P-x Communication Protocol	<a href="http://www.murata-ps.com/data/apnotes/acan-45.pdf">www.murata-ps.com/data/apnotes/acan-45.pdf</a>

Murata Power Solutions, Inc.  
 11 Cabot Boulevard, Mansfield, MA 02048-1151 U.S.A.  
 ISO 9001 and 14001 REGISTERED



**This product is subject to the following operating requirements and the Life and Safety Critical Application Sales Policy:**  
 Refer to: <http://www.murata-ps.com/requirements/>

Murata Power Solutions, Inc. makes no representation that the use of its products in the circuits described herein, or the use of other technical information contained herein, will not infringe upon existing or future patent rights. The descriptions contained herein do not imply the granting of licenses to make, use, or sell equipment constructed in accordance therewith. Specifications are subject to change without notice.  
 © 2014 Murata Power Solutions, Inc.