



FEATURES

- RoHS compliant
- Efficiency to 95%
- Industry standard footprint
- Short circuit protection
- Wide input range
- 1.8V, 2.5V, 3.3V & 5V Output
- Operating temperature range -40°C to 85°C
- SMD construction
- Optional shutdown & trim pins (NGA10S15050SEC & NGA10S15050DEC)

DESCRIPTION

The NGA series is a range of low profile DC/DC converters offering a single regulated output over a wide input voltage range. All parts deliver the full output power up to 85°C without the need for external heatsinking while the synchronous rectification design yields excellent efficiencies up to 95%.

SELECTION GUIDE

Order Code	Nominal Input Voltage V	Output Voltage V	Output Current		Nominal Input Current at Full Load			Power Consumption at Shutdown			Nominal Efficiency		Package Style
			Min. Load	Full Load	Min. V _{IN}	Nom. V _{IN}	Max. V _{IN}	Min. V _{IN}	Nom. V _{IN}	Max. V _{IN}	Min. V _{IN}	Max. V _{IN}	
			A		mA			mW			%		
NGA10S15018SC	15	1.8	0	2.0	847	280	160	0.5	4.8	16.1	89	81	SIP
NGA10S15018DC	15	1.8	0	2.0	847	280	160	0.5	4.8	16.1	89	81	DIP
NGA10S15025SC	15	2.5	0	2.0	1142	380	210	0.5	4.8	16.1	92	85	SIP
NGA10S15025DC	15	2.5	0	2.0	1142	380	210	0.5	4.8	16.1	92	85	DIP
NGA10S15033SC	15	3.3	0	2.0	1478	480	269	0.5	4.8	16.1	94	88	SIP
NGA10S15033DC	15	3.3	0	2.0	1478	480	269	0.5	4.8	16.1	94	88	DIP
NGA10S15050SC	15	5.0	0	2.0	1493	705	388	1.0	4.8	16.1	95	92	SIP
NGA10S15050DC	15	5.0	0	2.0	1493	705	388	1.0	4.8	16.1	95	92	DIP
NGA10S15050SEC ¹	15	5.0	0	2.0	1493	705	388	1.0	4.8	16.1	95	92	SIP
NGA10S15050DEC ¹	15	5.0	0	2.0	1493	705	388	1.0	4.8	16.1	95	92	DIP

RECOMMENDED ALTERNATIVES:

Order Code	Recommended Alternative	Order Code	Recommended Alternative
NGA10S15018SC	OKR-T/3-W12-C	NGA10S15033DC	78SRH-3.3/2-C
NGA10S15018DC	OKR-T/3-W12-C	NGA10S15050SC	78SR-5/2-C
NGA10S15025SC	OKR-T/3-W12-C	NGA10S15050DC	78SRH-5/2-C
NGA10S15025DC	OKR-T/3-W12-C	NGA10S15050SEC	OKR-T/3-W12-C
NGA10S15033SC	78SR-3.3/2-C	NGA10S15050DEC	OKR-T/3-W12-C

Note: Also see OKI-78SR series for ≤1.5A models. Click here for the data sheet »

INPUT CHARACTERISTICS

Parameter	Conditions	Min.	Typ.	Max.	Units
Voltage range	Continuous operation, 1.8V, 2.5V & 3.3V output types	4.75	15	28	V
	Continuous operation NGA10S15050SC	7.0	15	28	
	Continuous operation NGA10S15050SEC	Variable ²	15	28	
Reflected ripple current	1.8V output types		29		mA p-p
	2.5V output types		49		
	3.3V output types		48		
	5.0V output types		99		

OUTPUT CHARACTERISTICS

Parameter	Conditions	Min.	Typ.	Max.	Units
Rated power	T _A = -40°C to 85°C			10	W
Voltage set point accuracy			±1.5	±5.0	%
Line regulation	Low line to high line, with external input/output capacitors, refer to test circuit		0.2	0.5	%/%
Load regulation	10% load to 100% load, with external input/output capacitors, refer to test circuit		1.5	2.0	%
Ripple and noise	BW=DC to 20MHz, with external input/output capacitors, refer to test circuit		40	70	mVp-p

TEMPERATURE CHARACTERISTICS

Parameter	Conditions	Min.	Typ.	Max.	Units
Operation		-40		85	°C
Storage		-55		125	
PCB temperature above ambient			40		

1. If optional V_{ADJ} and SD pin are required (as indicated in the mechanical dimensions diagram) include an E in the part number when ordering, i.e. NGA10S15050SEC & NGA10S15050DEC.
2. Supply voltage should exceed output voltage by 1.45V.

All specifications typical at T_A=25°C, nominal input voltage and rated output current unless otherwise specified.



For full details go to www.murata-ps.com/rohs



ABSOLUTE MAXIMUM RATINGS	
Short-circuit protection	Continuous
Lead temperature 1.5mm from case for 10 seconds	300°C
Internal power dissipation	1.1W
Input voltage V_{IN}	28V
Minimum load	0%
Output trim control	0V to +5V relative to COMMON
Shutdown control	-0.3V to +28V relative to COMMON

GENERAL CHARACTERISTICS					
Parameter	Conditions	Min.	Typ.	Max.	Units
Switching frequency		270	300	330	kHz
Transient response Max. over-shoot	50% load change, 1.8V output types		90 (160)		mV (μ s)
	50% load change, 2.5V output types		84 (145)		
	50% load change, 3.3V output types		83 (130)		
	50% load change, 5.0V output types		75 (40)		
Transient response Max. under-shoot	50% load change, 1.8V output types		64 (160)		mV (μ s)
	50% load change, 2.5V output types		86 (145)		
	50% load change, 3.3V output types		84 (120)		
	50% load change, 5.0V output types		74 (80)		
Under voltage lock out	1.8V, 2.5V & 3.3V output types		4.0		V
	5.0V output types		5.0		
Start delay	V_{IN} Min. to V_{IN} Max.		100		ms
ESD	400VDC from 100pF capacitor via 1500 Ω resistance	Meets MIL-STD-883F method 3015.7			

APPLICATION NOTES

External Capacitance

External capacitors are necessary in order to guarantee stability and full parametric performance over the full line and load range. All parts have been tested and characterised using the following values and test circuit.

Value	
C _{IN}	C _{OUT}
100µF, 50V	100µF, 10V

Voltage trimming

The trimming (adjust) input on the device allows output voltage adjustment to within ±5%¹ of the desired V_{OUT} using a resistor with a value determined by the following equations.

When open circuit, the output will be +5V.

A resistor (R_D) between the trim pin and the output pin will adjust the output voltage between +5V to +1.8V.

$$\frac{1}{R_D} = (22 [1.028V_o - 1])^{-1} - 0.011$$

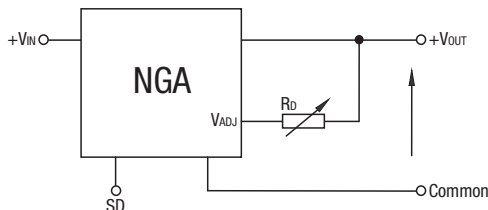

A resistor (R_U) between the trim pin and the Common pin will adjust the device output from +5V to +5.5V.

$$\frac{1}{R_U} = \left(\frac{1.028V_o - 1}{91} \right) - 0.0455$$

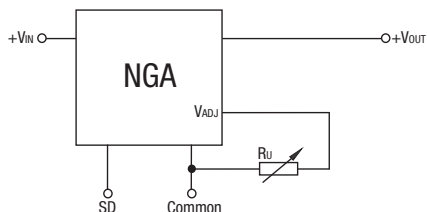

Test Circuit

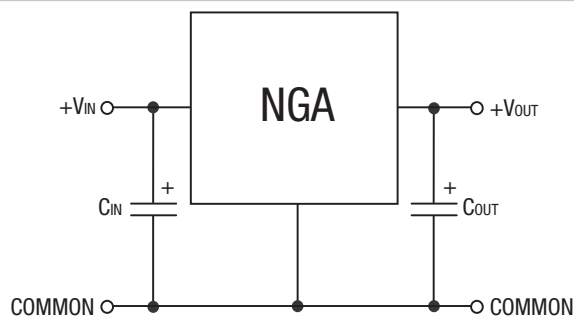

Shutdown

When the shutdown pin is shorted to Common, the device's output will be disabled. To shutdown the device the pin should be taken below 0.8V using either an open collector pull down or by using isolated delay contacts. To enable the device output the shutdown pin should be left floating or taken no lower than +1.5V to a maximum of (+28V).

If the shutdown pin is to be connected to a long wire, it is recommended that a capacitor (10nF) decouples the shutdown pin to Common in order to avoid the risk of injecting noise into the device circuit.

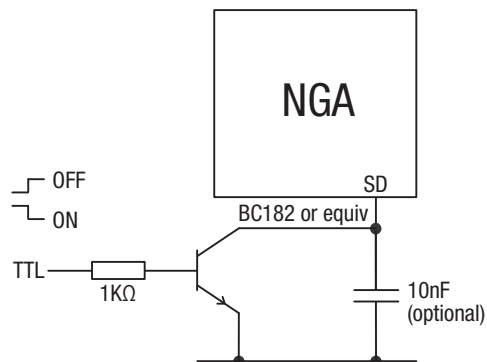

All specifications typical at T_A=25°C, nominal input voltage and rated output current unless otherwise specified.

1. Accuracy of adjustment is subject to tolerance of resistors and initial output accuracy.

MEAN TIME TO FAILURE (MTTF)¹

Part number	25°C	Units
NGA10S15018	1464	KHrs
NGA10S15025	1463	
NGA10S15033	1463	
NGA10S15050	1461	

TERMINOLOGY

Transient Response	Over-Shoot/Under-Shoot	Start Delay
Time for V _{OUT} to be within 1% of V _{NOM} where: $V_{NOM} = \frac{V_{OUT\ 25\%} + V_{OUT\ 75\%}}{2}$	Max. deviation from final steady state output.	Typical rise time (ms) after control pin high with valid input.

PACKAGE SPECIFICATIONS

MECHANICAL DIMENSIONS - SIP PACKAGE

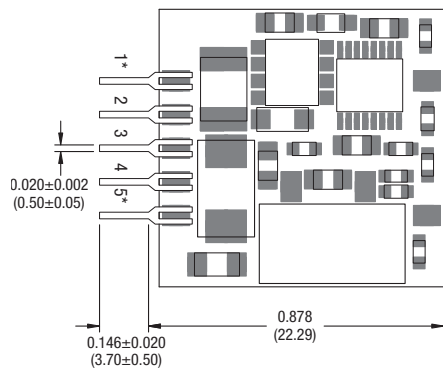
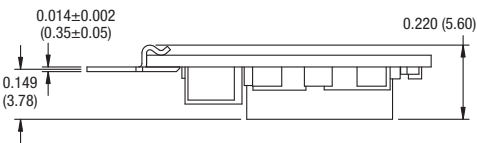
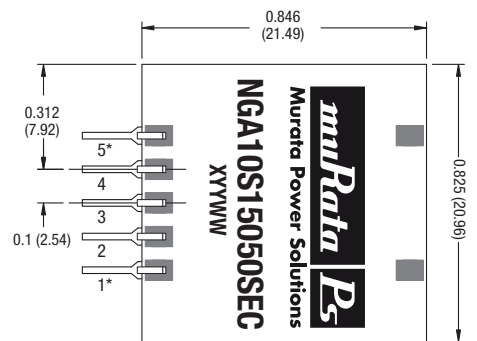

All dimensions in inches ±0.01 (mm ±0.25mm).
All pins on a 0.1 (2.54) pitch and within ±0.01 (0.25) of true position.

RECOMMENDED FOOTPRINT

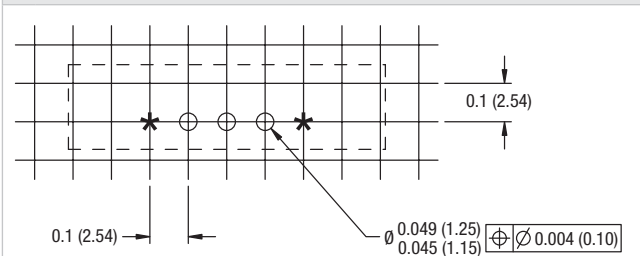

All dimensions in inches ±0.01 (mm ±0.25mm).
All pins on a 0.1 (2.54) pitch and within ±0.01 (0.25) of true position.

PIN CONNECTIONS

Pin	Function
1*	SD
2	+V _{IN}
3	COMMON
4	+V _{OUT}
5*	V _{ADJ}

Weight: 4.0g
* Optional pins available on NGA10S15050SEC only

1. Calculated using MIL-HDBK-217F with nominal input voltage at full load.

PACKAGE SPECIFICATIONS (continued)

MECHANICAL DIMENSIONS - DIP PACKAGE

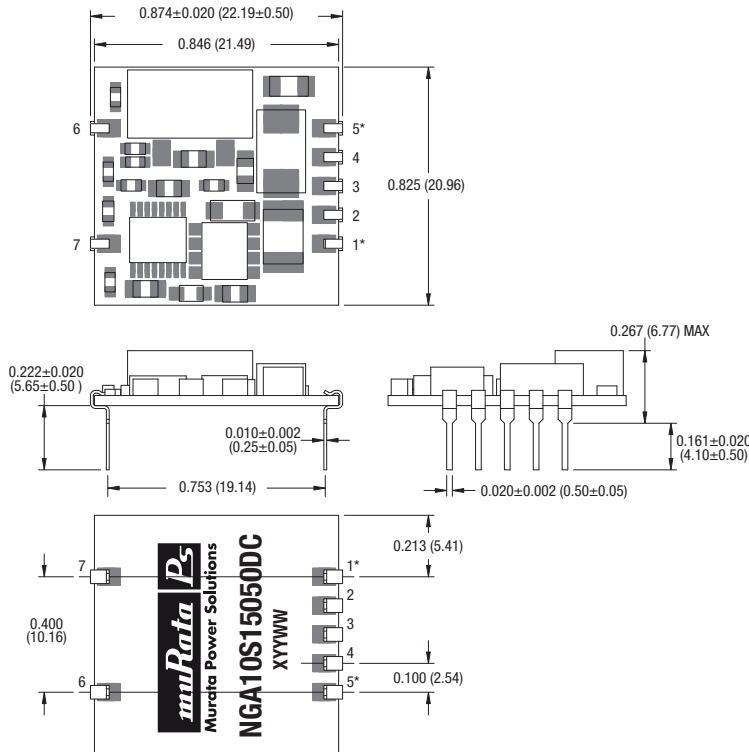

All dimensions in inches ± 0.01 (mm ± 0.25 mm) except where stated otherwise.
All pins on a 0.1 (2.54) pitch and within 0.01 (0.25) of true position.

RECOMMENDED FOOTPRINT

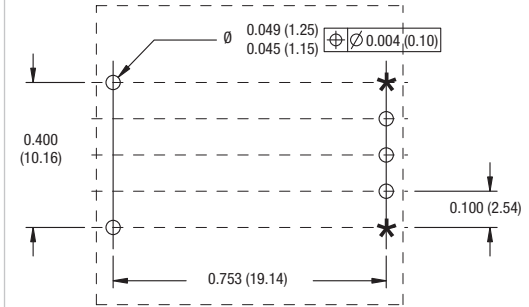

All dimensions in inches ± 0.01 (mm ± 0.25 mm).
All pins on a 0.1 (2.54) pitch and within 0.01 (0.25) of true position.

PIN CONNECTIONS

Pin	Function
1*	SD
2	+VIN
3	COMMON
4	+VOUT
5*	VADJ
6	NC
7	NC

Weight: 4.0g

* Optional pins available on NGA10S15050DEC only

RoHS COMPLIANCE INFORMATION



This series is compatible with RoHS soldering systems with a peak wave solder temperature of 300°C for 10 seconds. The pin termination finish on the SIP package type is Tin Plate, Hot Dipped over Matte Tin with Nickel Preplate and Tin on the DIP types. Both types in this series are backward compatible with Sn/Pb soldering systems.

For further information, please visit www.murata-ps.com/rohs

PACKAGE SPECIFICATIONS (continued)

TRAY DIMENSIONS - SIP PACKAGE

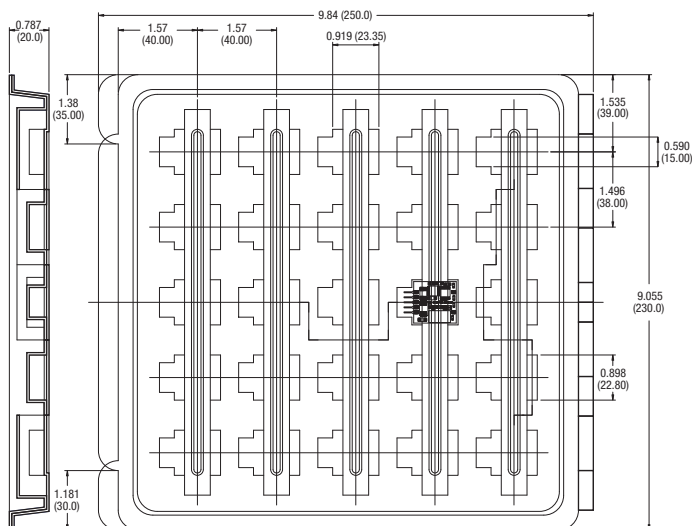

Tray quantity: 25
All dimensions in inches ± 0.01 (mm ± 0.25 mm).

TRAY DIMENSIONS - DIP PACKAGE

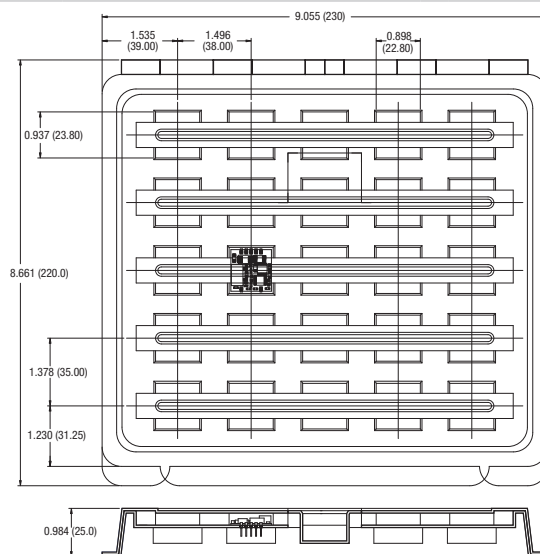

Tray quantity: 25
All dimensions in inches ± 0.01 (mm ± 0.25 mm).

Murata Power Solutions, Inc.
11 Cabot Boulevard, Mansfield, MA 02048-1151 U.S.A.
ISO 9001 and 14001 REGISTERED

Murata Power Solutions, Inc. makes no representation that the use of its products in the circuits described herein, or the use of other technical information contained herein, will not infringe upon existing or future patent rights. The descriptions contained herein do not imply the granting of licenses to make, use, or sell equipment constructed in accordance therewith. Specifications are subject to change without notice.
© 2011 Murata Power Solutions, Inc.