

HALO Electronics has developed this low cost series of 2 watt DC/DC Converters to specifically address the power and isolation requirements of IEEE 802.3 for 10BASE2 applications. Additional output voltages are available for other isolated voltage applications.

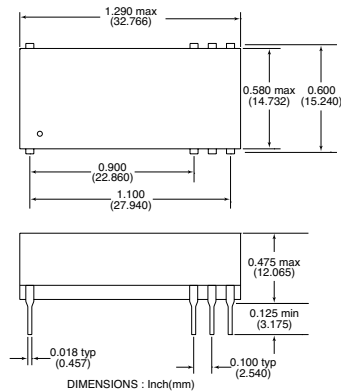

**Package C**



**Package D**

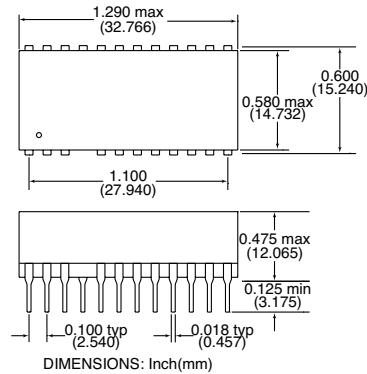

**Package MD**

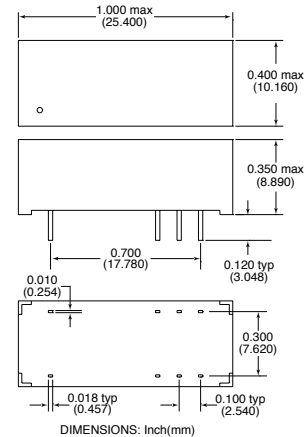

**Electrical Specifications @ 25°C**

Isolation Voltage:	500 Vrms
Output Volt. Accuracy (Nom. Vin / Full Load):	±5%
Output Noise/Ripple (20MHz Bandwidth):	100 mVp-p Max
Line Voltage Regulation @ Full Load:	1.25%/1% of Vin
Load Regulation (No Load to Full Load):	15% Max
Efficiency at Full Load:	70% Min
Operating Temperature:	0° to 70° C
Storage Temperature:	-40° to 125° C

**Pin Connections**

Function	C / D	MD
Input +	1, 24	1, 16
Input -	12, 13	8, 9
Output +	11, 14	7, 10
Output -	10, 15	6, 11

Part Number	Package	Input Voltage / Current (Max.)	Output Voltage / Current (Max.)
DCU0-0509C	C	5 Vdc @ 600 mA	9 Vdc @ 250 mA
DCU0-0509D	D	5 Vdc @ 600 mA	9 Vdc @ 250 mA
DCU0-0509MD	MD	5 Vdc @ 600 mA	9 Vdc @ 225 mA
DCU0-0512C	C	5 Vdc @ 600 mA	12 Vdc @ 185 mA
DCU0-0512D	D	5 Vdc @ 600 mA	12 Vdc @ 185 mA
DCU0-0512MD	MD	5 Vdc @ 600 mA	12 Vdc @ 180 mA
DCU0-1209C	C	12 Vdc @ 250 mA	9 Vdc @ 250 mA
DCU0-1209D	D	12 Vdc @ 250 mA	9 Vdc @ 250 mA
DCU0-1209MD	MD	12 Vdc @ 250 mA	9 Vdc @ 225 mA

# HALO DC/DC Converters with Enable Feature

HALO ELECTRONICS, INC.

HALO Electronics has developed this standard series of Enabled DC/DC Converters to specifically address the power and isolation requirements for 10BASE2 and 10BASE5 applications. For non-standard, application specific, requirements please contact your local Representative.



**Package E**

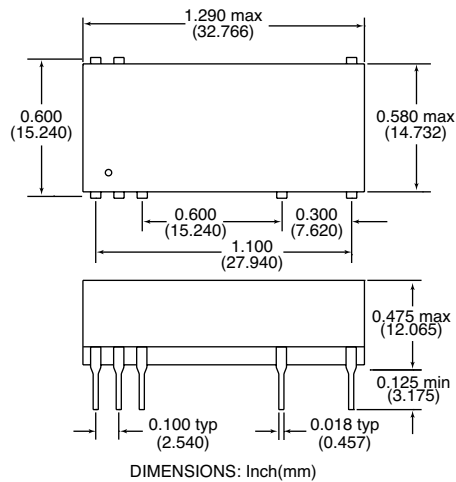

**Package E1**

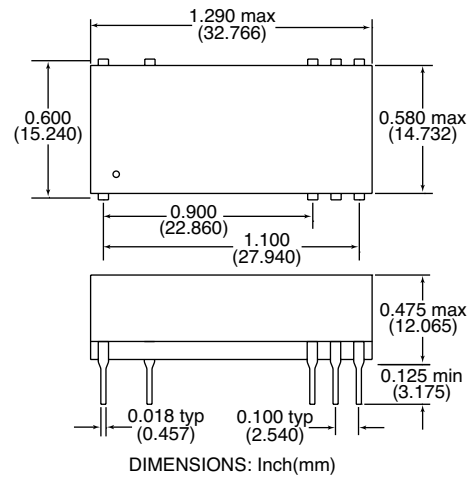

DC/DC Converters with Enable Feature

**Electrical Specifications @ 25°C**

Enable (TTL Compatible):	0.2 mA Max.
Output Voltage Accuracy (Nom. Vin / Full Load):	±5%
Output Noise/Ripple (20MHz Bandwidth):	100mVp-p Max.
Line Voltage Regulation:	1.25% / 1% of Vin
Load Regulation (No Load to Full Load):	15% Max.
Efficiency at Full Load:	70% Min.
Operating Temperature:	0° to 70° C
Storage Temperature:	-40° to 125° C

**Pin Connections**

Function	DCU-E	DCU-E1
Input +	1, 2	1, 24
Input -	23, 24	12, 13
Enable	3	22
Output +	12	11, 14
Output -	9	10, 15
N/C	13	

Part Number	Input (Max.) Voltage/Current	Output (Max.) Voltage/Current	Isolation Vrms	Enable Function
DCU0-0509E	5 Vdc @ 600 mA	9 Vdc @ 250 mA	500	Active Low
DCU0-1209E	12 Vdc @ 250 mA	9 Vdc @ 250 mA	500	Active Low
DCU0-0509E1	5 Vdc @ 600 mA	9 Vdc @ 250 mA	500	Active High
DCU0-1209E1	12 Vdc @ 250 mA	9 Vdc @ 250 mA	500	Active High
DCU2-0509E	5 Vdc @ 600 mA	9 Vdc @ 250 mA	2,000	Active Low
DCU2-1209E	12 Vdc @ 250 mA	9 Vdc @ 250 mA	2,000	Active Low