

HDC140 Series

Low Profile SMD Drum Core Inductors

HALO
ELECTRONICS, INC.



Product Features:

- Low cost series of miniature power inductors
- Ideal for portable equipment such as hand-held PDA's, palmtop computers as well as test equipment
- Available in tape and reel packaging.
- Please contact your representative for custom designs.

Part Number	IND $\pm 20\%$ (μH)	DCR (max) (ohm)	SRF (typ) (MHz)	IDC (max) ¹ (A)
HDC140-100MTR	10	0.11	35	2.4
HDC140-150MTR	15	0.15	33	2.0
HDC140-220MTR	22	0.23	25	1.6
HDC140-330MTR	33	0.30	19	1.4
HDC140-470MTR	47	0.39	14	1.0
HDC140-680MTR	68	0.66	12	0.9
HDC140-101MTR	100	0.84	10	0.7
HDC140-151MTR	150	1.20	8.0	0.6
HDC140-221MTR	220	1.9	6.0	0.5
HDC140-331MTR	330	2.7	5.0	0.4
HDC140-471MTR	470	4.0	4.0	0.3
HDC140-681MTR	680	5.3	3.0	0.2
HDC140-102MTR	1000	8.4	2.5	0.1

Notes:

1. DC current that will cause inductance (L) drop by 10% from nominal value
2. Operating temperature range of -40C to +85C

HDC140 Series

Package Dimensions (mm)

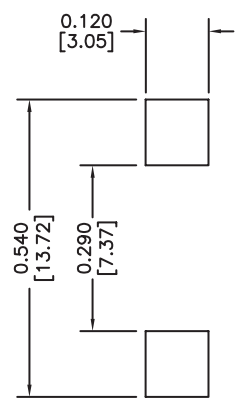
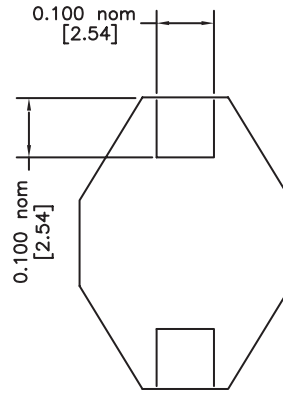
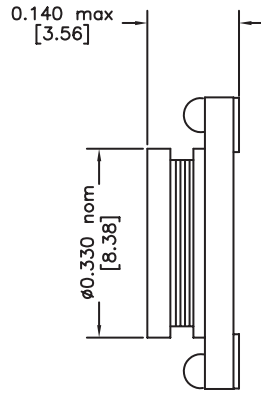
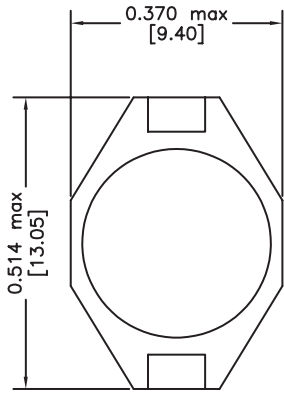

Tape & Reel Specifications

HDC140-

1500 PARTS PER REEL

CARRIER TAPE DIMENSIONS (mm)

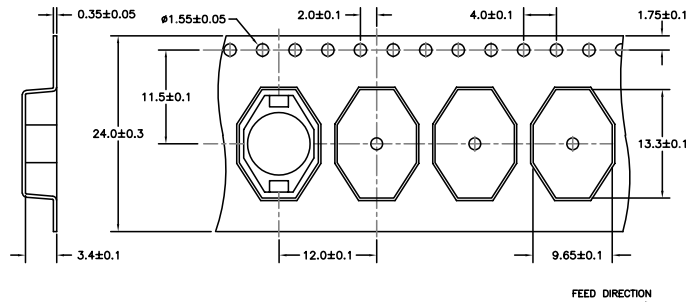

REEL DIMENSIONS (mm)

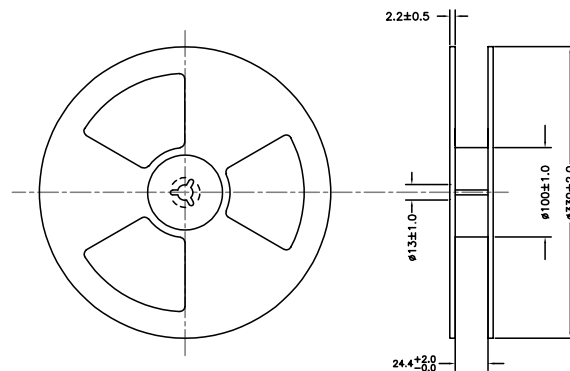

2880 Lakeside Drive #116
 Santa Clara, CA 95054
 (650) 903-3800
www.haloelectronics.com

HALO® Electronics is a leading supplier of high quality communication magnetics including signal transformers, filters, CMR chokes, PoE power transformers, DC/DC converters, and integrated Ethernet connectors. HALO's leading edge technology solutions are manufactured in ISO9001 and ISO14001 factories offering high quality products at a competitive price.

HDC205 Series

SMD Drum Core Inductors

HALO
ELECTRONICS, INC.



Product Features:

- Low cost series of SMD miniature power inductors
- The high energy storage capability makes the HDC205 series ideal for DC-DC conversion in handheld PDA's and notebook computers
- Available in tape and reel packaging.
- Please contact your representative for custom designs.

Part Number	IND $\pm 20\%$ (μH)	DCR (max) (ohm)	SRF (typ) (MHz)	IDC (max) ¹ (A)
HDC205-1R0MTR	1.0	.009	100	9.0
HDC205-1R5MTR	1.5	.010	90	8.0
HDC205-2R2MTR	2.2	.012	80	7.0
HDC205-3R3MTR	3.3	.015	65	6.4
HDC205-4R7MTR	4.7	.018	45	5.4
HDC205-6R8MTR	6.8	.027	38	4.6
HDC205-100MTR	10	.038	30	3.8
HDC205-150MTR	15	.046	27	3.0
HDC205-220MTR	22	.085	19	2.6
HDC205-330MTR	33	0.10	15	2.0
HDC205-470MTR	47	0.14	12	1.6
HDC205-680MTR	68	0.20	10	1.4
HDC205-101MTR	100	0.28	9.0	1.2
HDC205-151MTR	150	0.40	6.0	1.0
HDC205-221MTR	220	0.61	5.0	0.8
HDC205-331MTR	330	1.02	4.5	0.6
HDC205-471MTR	470	1.27	3.5	0.5
HDC205-681MTR	680	2.02	2.5	0.4
HDC205-102MTR	1000	3.00	2.0	0.3

Notes:

1. DC current that will cause inductance (L) drop by 10% from nominal value
2. Operating temperature range of -40C to +85C

HDC205 Series

Package Dimensions (mm)

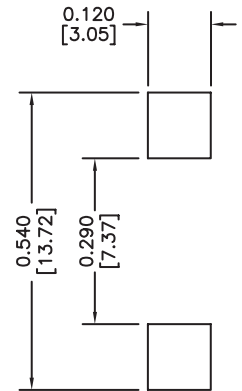
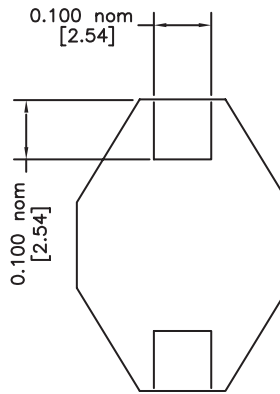
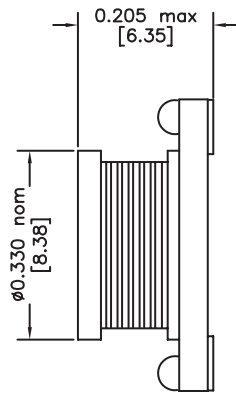
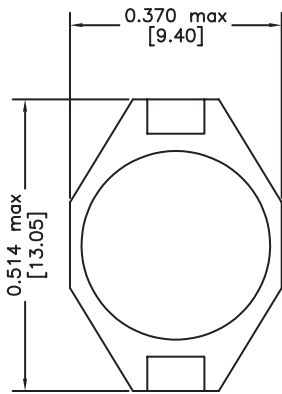

Tape & Reel Specifications

HDC205-

1000 PARTS PER REEL

CARRIER TAPE DIMENSIONS (mm)

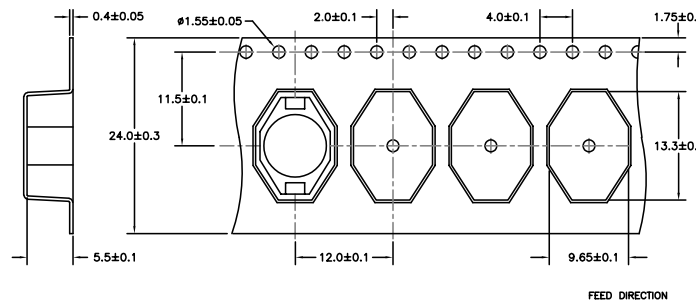

REEL DIMENSIONS (mm)

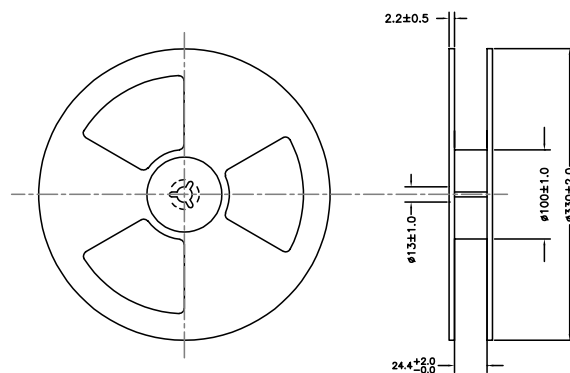

2880 Lakeside Drive #116
Santa Clara, CA 95054
(650) 903-3800
www.haloelectronics.com

HALO® Electronics is a leading supplier of high quality communication magnetics including signal transformers, filters, CMR chokes, PoE power transformers, DC/DC converters, and integrated Ethernet connectors. HALO's leading edge technology solutions are manufactured in ISO9001 and ISO14001 factories offering high quality products at a competitive price.

HDC450 Series

High Profile SMD Drum Core Inductors

HALO
ELECTRONICS, INC.



Product Features:

- High current, low cost series of power inductors provides excellent current handling capabilities
- Available in tape and reel packaging.
- Please contact your representative for custom designs.

Part Number	IND $\pm 20\%$ (μH)	DCR (max) (ohm)	SRF (typ) (MHz)	IDC (max) ¹ (A)
HDC450-100MTR	10	0.04	22	8.0
HDC450-150MTR	15	0.05	18	7.0
HDC450-220MTR	22	0.066	11	5.5
HDC450-330MTR	33	0.08	9.0	4.0
HDC450-470MTR	47	0.11	8.0	3.8
HDC450-680MTR	68	0.17	7.0	3.0
HDC450-101MTR	100	0.22	5.0	2.5
HDC450-151MTR	150	0.34	4.0	2.0
HDC450-221MTR	220	0.44	3.5	1.6
HDC450-331MTR	330	0.70	2.5	1.2
HDC450-471MTR	470	0.95	2.0	1.0
HDC450-681MTR	680	1.20	2.0	1.0
HDC450-102MTR	1000	2.00	1.5	0.8

Notes:

1. DC current that will cause inductance (L) drop by 10% from nominal value
2. Operating temperature range of -40C to +85C

HDC450 Series

Package Dimensions (mm)

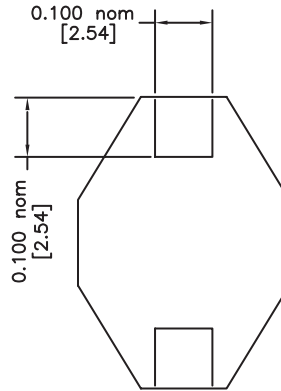
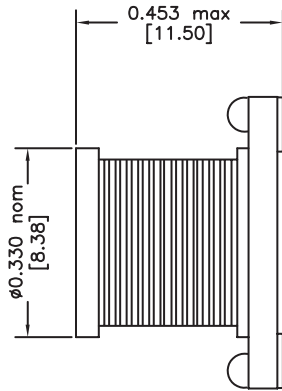
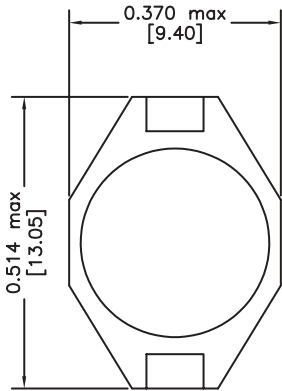

Recommended Solder Pad

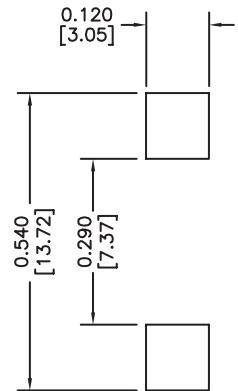

Tape & Reel Specifications

HDC450-

250 PARTS PER REEL

CARRIER TAPE DIMENSIONS (mm)

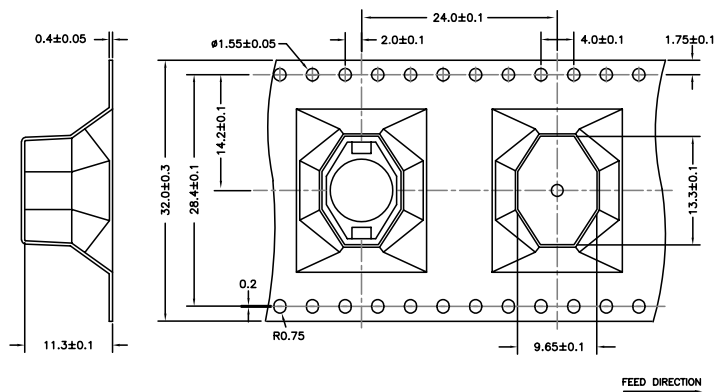

REEL DIMENSIONS (mm)

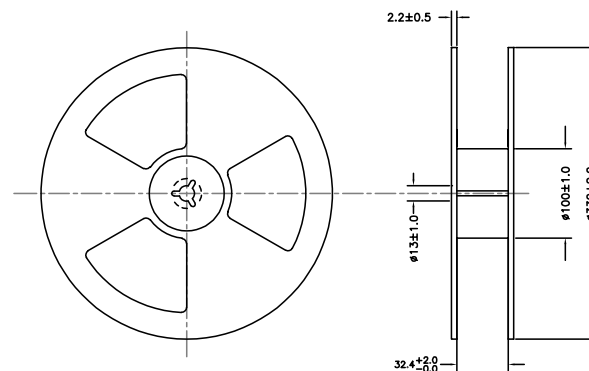

2880 Lakeside Drive #116
Santa Clara, CA 95054
(650) 903-3800
www.haloelectronics.com

HALO® Electronics is a leading supplier of high quality communication magnetics including signal transformers, filters, CMR chokes, PoE power transformers, DC/DC converters, and integrated Ethernet connectors. HALO's leading edge technology solutions are manufactured in ISO9001 and ISO14001 factories offering high quality products at a competitive price.