

The TGAD-NARL series of 6 pin transformers has been designed specifically to work in conjunction with the Analog Devices, Inc. Quad Channel Isolators with integrated transformer drivers. These "Operational" isolation modules are UL/EN60950 recognized for SELV applications. Other series are available with isolation voltages up to 4.5KVrms. Analog Devices is a trademark of Analog Devices Inc. For more information please go to iCoupler_digital_isolation_portfolio.

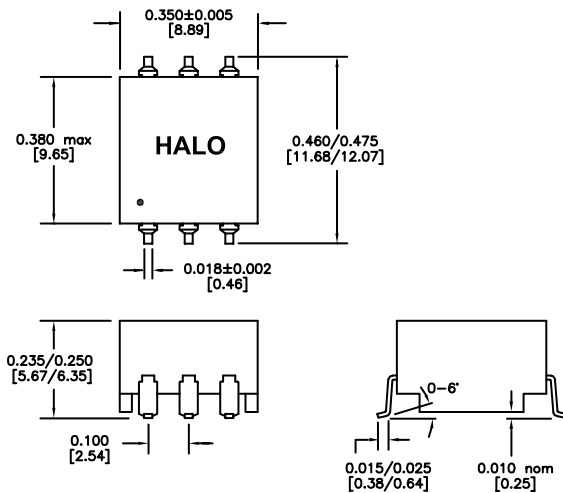

TGAD-NARL Package



DIMENSIONS: Inch(mm)
 CO-PLANARITY: 0.004(0.102)

Circuit Diagram

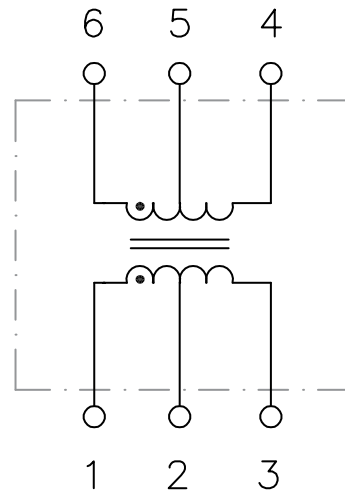

Patented Construction

US Pat Nbrs: 5,656,985 6,297,721 B1
 6,297,720 B1 6,320,489 B1
 6,344,785 B1 6,662,431 B1

Electrical Specifications @ 25°C
 Operating Temp: -40 to +85°C
 PRI Pins: 1-3
 PRI OCL: 389µH typ.
 PRI DCR: 0.8Ω



Part Number	Turns Ratio +/-3%	ET Constant	Isolation
SMD	PRI : SEC	V-us Min*	Vrms
TGAD-260NARL	1CT:2CT	14	1,500
TGAD-290NARL	1CT:3CT	14	1,500
TGAD-292NARL	1CT:5CT	14	1,500

* Minimum ET Constant over operating temperature range