

BLUETECHNIX
Embedding Ideas

NFC Adapter - Programmable

Hardware User Manual

Version 1.3

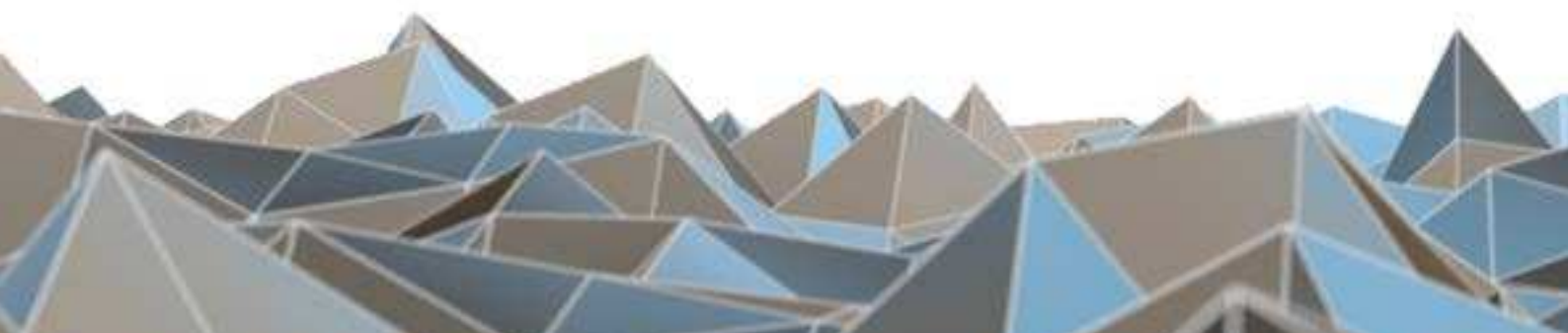



Contact

Bluetechnix Mechatronische Systeme GmbH

Waidhausenstraße 3/19

A-1140 Vienna

AUSTRIA

office@bluetechnix.com

<http://www.bluetechnix.com>

Document No.: 900-306 / A

Date: 2013-05-22



Table of Contents

1	Introduction	4
1.1	Overview	4
1.2	Key Features	4
1.3	Applications.....	4
2	General Description.....	5
2.1	Functional Description	5
2.2	Boot Mode	6
3	Specifications	7
3.1	Electrical Specifications	7
3.1.1	Operating Conditions.....	7
3.1.2	Maximum Ratings	7
3.1.3	ESD Sensitivity.....	7
4	Connector Description	8
4.1	Connector X1 - JTAG.....	8
4.2	Connector X2 – USB-A	8
4.3	Test points Px	8
5	Mechanical Outline.....	9
5.1	Top View	9
5.2	Bottom View.....	9
6	Support.....	10
6.1	General Support.....	10
7	Ordering Information	11
7.1	NFC Adapter - Programmable	11
8	Dependability	12
8.1	MTBF.....	12
9	Product History	13
9.1	Version Information	13
9.1.1	NFC Adapter - Programmable).....	13
9.2	Anomalies.....	13
10	Document Revision History	14
11	List of Abbreviations	15
A	List of Figures and Tables	16

© Bluetechnix GmbH 2013

All Rights Reserved.

The information herein is given to describe certain components and shall not be considered as a guarantee of characteristics.

Terms of delivery and rights of technical change reserved.

We hereby disclaim any warranties, including but not limited to warranties of non-infringement, regarding circuits, descriptions and charts stated herein.

Bluetechnix makes and you receive no warranties or conditions, express, implied, statutory or in any communication with you. Bluetechnix specifically disclaims any implied warranty of merchantability or fitness for a particular purpose.

Bluetechnix takes no liability for any damages and errors causing of the usage of this board. The user of this board is responsible by himself for the functionality of his application. He is allowed to use the board only if he has the qualification. More information is found in the General Terms and Conditions (AGB).

Information

For further information on technology, delivery terms and conditions and prices please contact Bluetechnix (<http://www.bluetechnix.com>).

Warning

Due to technical requirements components may contain dangerous substances.

1 Introduction

The NFC Adapter - Programmable is a development dongle especially designed for contactless general purpose Near-Field-Communications (NFC) applications. This adapter is based on the contactless RFID 13.56 MHz technology and supports NFCIP-1 mode (ISO/IEC 18092), ISO 14443A/Mifare as well as ISO 14443B reader/writer standards. Supported contactless smart cards are MIFARE and FeliCa. For easy usage, it has an onboard JTAG connector and is powered through a USB-A Connector.

1.1 Overview

Figure 1.1 shows the main components of the NFC Adapter - Programmable.

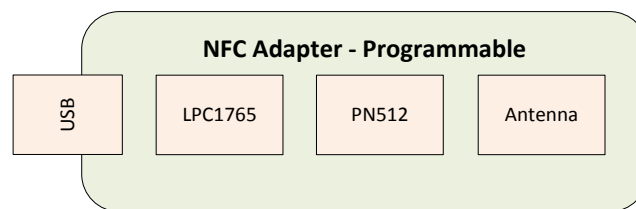

Figure 1.1: Main components of the NFC Adapter - Programmable

1.2 Key Features

- NXP LPC1765 (ARM Cortex M3) Processor
- PN512 RFID chip
 - Reader/Writer mode supporting ISO/IEC 14443A/MIFARE and FeliCa scheme
 - Reader/Writer mode supporting ISO/IEC 14443B
 - Card Operation mode supporting ISO/IEC 14443A/MIFARE and FeliCa scheme
 - NFCIP-1 mode (ISO/IEC 18092)
- Connectors
 - USB-A connector for power supply and host communication
 - JTAG

1.3 Applications

- Access control
- Authentication
- Micro-payment
- NFC mobile tag
- Online purchase
- Customer loyalty
- Time and attendance
- e-payment

2 General Description

2.1 Functional Description

The NFC Adapter - Programmable includes the following components:

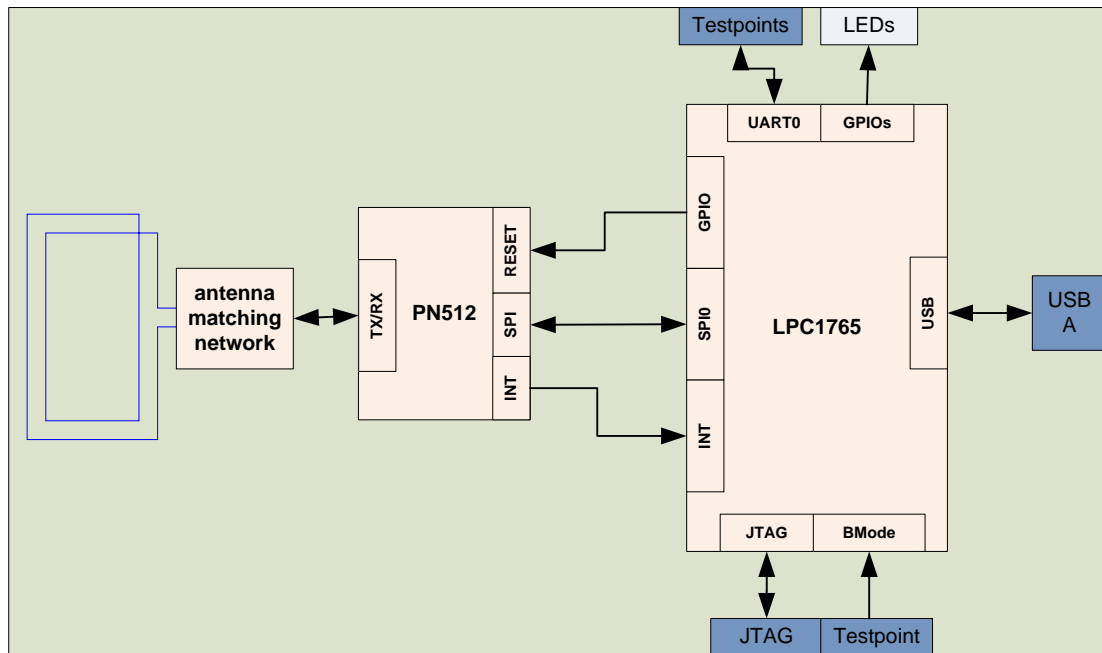

Figure 2.1: Overview of the NFC Adapter - Programmable

- Processor
 - NXP LPC1765FBD100
 - 256KB FLASH
 - 64KB RAM
 - High speed USB 2.0 interface
- RFID chip
 - NXP PN512 connected to LPC1765 via SPI
- JTAG
 - JTAG-Plug that supports the ARM JTAG through a special JTAG adapter
- USB A
 - Standard USB A interface connected to LPC1765
- Power supply
 - 5V power supply through USB A connector
- Antenna matching network
 - Matching of the antenna impedance to the PN512 impedance



- Increasing the antenna bandwidth (at 13,56MHz)
- Reducing electromagnetic emission
- Loop antenna
 - Loop antenna printed on PCB (3R / 3μH at 13,56MHz)
- LEDs
 - Dual color status LED connected to the LPC1765

Pin No.	Signal Name	Type	Function
32	P1.18	I/O	LED red
34	P1.20	I/O	LED green

Table 2.1: Status LEDs

2.2 Boot Mode

- Enable UART Boot mode
 - To enter UART boot, P1 has do be set to GND before powering the board.
 - In UART boot mode, the firmware can be flashed through P5(RX), P6(TX) by using the NXP “Flash magic” or another UART flash programming tool.



3 Specifications

3.1 Electrical Specifications

3.1.1 Operating Conditions

Symbol	Parameter	Min	Typical	Max	Unit
V_{IN}	Input supply voltage	4.5	5	5.5	V

Table 3.1: Electrical characteristics

3.1.2 Maximum Ratings

Stressing the device above the rating listed in the absolute maximum ratings table may cause permanent damage to the device. These are stress ratings only. Operation of the device at these or any other conditions greater than those indicated in the operating sections of this specification is not implied. Exposure to absolute maximum rating conditions for extended periods may affect device reliability.

Symbol	Parameter	Min	Max	Unit
V_{IN}	Input supply voltage	4.3	7	V
T_{STO}	Storage temperature	-40	90	°C
T_{OP}	Operating temperature	-20	70	°C
ϕ_{AMB}	Relative ambient humidity		90	%

Table 3.2: Absolute maximum ratings

3.1.3 ESD Sensitivity



ESD (electrostatic discharge) sensitive device. Charged devices and circuit boards can discharge without detection. Although this product features patented or proprietary protection circuitry, damage may occur on devices subjected to high energy ESD. Therefore, proper ESD precautions should be taken to avoid performance degradation or loss of functionality.



4 Connector Description

4.1 Connector X1 - JTAG

Pin No.	Signal Name	Type	Function
1	TDI	I - 10k pull up	Test Data In
2	RTCK	I/O - 4k7 pull down	JTAG Interface Control
3	TMS	I/O - 10k pull up	Test Mode Select
4	TDO	O - 10k pull up	Test Data Out
5	nTRST	I - 10k pull up	Test Reset
6	NC	-	-
7	TCK	I - 4k7 pull down	Test Clock
8	3V3	Power	
9	nRESET	I - 10k pull up	External Reset
10	GND	Power	

Table 4.1: Connector description X1

4.2 Connector X2 - USB-A

Pin No.	Signal Name	Type	Function
1	VCC	Power	
2	D-	I/O	USB D- line
3	D+	I/O	USB D+ line
4	GND	Power	

Table 4.2: Connector description X2

4.3 Test points Px

Pin No.	Signal Name	Type	Function
P1	P2.10	Power	A LOW level on this pin during reset starts the ISP command handler.
P2	GND	I/O	USB D- line
P3	3V3	I/O	USB D+ line
P4	VUSB	Power	
P5	UART0 RX	I/O	Transmitter output for UART 0
P6	UART0 TX	I/O	Transmitter output for UART 0
P7	USB D+	I/O	USB D+ line
P8	USB D-	I/O	USB D- line
P9	VUSB	Power	

Table 4.3: Test point description



5 Mechanical Outline

5.1 Top View

Figure 5.1 shows the top view of the mechanical outline of the NFC Adapter - Programmable. All dimensions are given in millimeters! Outline dimensions +/- 0,5mm.

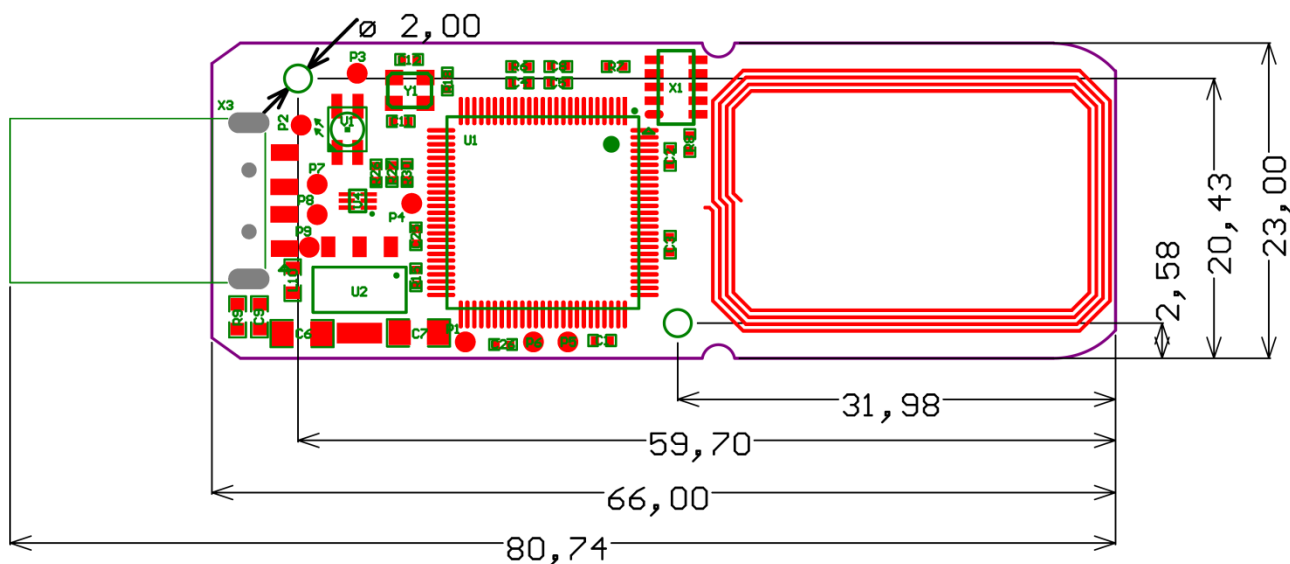

Figure 5.1: Mechanical outline (top view)

5.2 Bottom View

Figure 5-2 shows the bottom of the mechanical outline of the NFC Adapter - Programmable. All dimensions are given in millimeters!

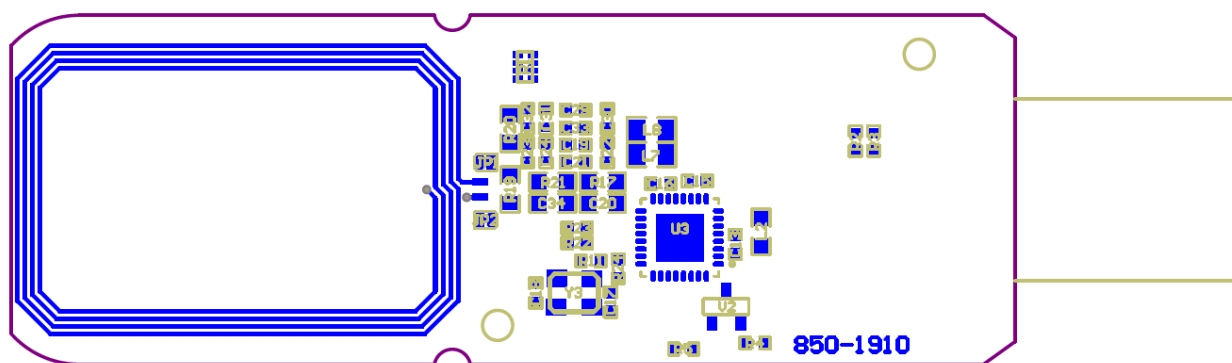

Figure 5-2: Mechanical outline (bottom view)



6 Support

6.1 General Support

General support for products can be found at Bluetechnix' support site <https://support.bluetechnix.at/wiki>



7 Ordering Information

7.1 NFC Adapter - Programmable

Article Number	Name	Temperature Range
100-3600-1	NFC Adapter – Programmable Kit	Commercial

Table 7.1: Ordering information

NOTE: Custom Core Modules are available on request! Please contact Bluetechnix (office@bluetechnix.com) if you are interested in custom Core Modules.



8 Dependability

8.1 MTBF

Please keep in mind that a part stress analysis would be the only way to obtain significant failure rate results, because MTBF numbers just represent a statistical approximation of how long a set of devices should last before failure. Nevertheless, we can calculate an MTBF of the Core Module using the bill of material. We take all the components into account. The PCB and solder connections are excluded from this estimation. For test conditions we assume an ambient temperature of 30°C of all Core Module components except the Blackfin® processor (80°C) and the memories (70°C). We use the MTBF Calculator from ALD (<http://www.aldservice.com/>) and use the reliability prediction MIL-217F2 Part Stress standard. Please get in touch with Bluetechnix (office@bluetechnix.com) if you are interested in the MTBF result.



9 Product History

9.1 Version Information

9.1.1 NFC Adapter - Programmable)

Version	Date	Type
1.2	2011 02 11	First release of the hardware.

Table 9.1: Overview NFC Adapter - Programmable product changes

9.2 Anomalies

Version	Date	Description
1.2	2011 02 11	No anomalies reported yet.

Table 9.2: Product anomalies



10 Document Revision History

Version	Date	Document Revision
1	2012 08 16	First release V1.0 of the Document
2	2013 04 10	Updated Support chapter
3	2013 05 22	Updated ordering information

Table 10.1: Revision history



11 List of Abbreviations

Abbreviation	Description
ADI	Analog Devices Inc.
AI	Analog Input
AMS	Asynchronous Memory Select
AO	Analog Output
CM	Core Module
DC	Direct Current
DSP	Digital Signal Processor
eCM	Enhanced Core Module
EBI	External Bus Interface
ESD	Electrostatic Discharge
GPIO	General Purpose Input Output
I	Input
I²C	Inter-Integrated Circuit
I/O	Input/Output
ISM	Image Sensor Module
LDO	Low Drop-Out regulator
MTBF	Mean Time Between Failure
NC	Not Connected
NFC	NAND Flash Controller
O	Output
OS	Operating System
PPI	Parallel Peripheral Interface
PWR	Power
RTOS	Real-Time Operating System
SADA	Stand Alone Debug Agent
SD	Secure Digital
SoC	System on Chip
SPI	Serial Peripheral Interface
SPM	Speech Processing Module
SPORT	Serial Port
TFT	Thin-Film Transistor
TISM	Tiny Image Sensor Module
TSC	Touch Screen Controller
UART	Universal Asynchronous Receiver Transmitter
USB	Universal Serial Bus
USBOTG	USB On The Go
ZIF	Zero Insertion Force

Table 11.1: List of abbreviations



A List of Figures and Tables

Figures

Figure 1.1: Main components of the NFC Adapter - Programmable	4
Figure 2.1: Overview of the NFC Adapter - Programmable	5
Figure 5.1: Mechanical outline (top view)	9
Figure 5-2: Mechanical outline (bottom view)	9

Tables

Table 2.1: Status LEDs	6
Table 3.1: Electrical characteristics	7
Table 3.2: Absolute maximum ratings	7
Table 4.1: Connector description X1	8
Table 4.2: Connector description X2	8
Table 4.3: Test point description	8
Table 7.1: Ordering information	11
Table 9.1: Overview NFC Adapter - Programmable product changes	13
Table 9.2: Product anomalies	13
Table 10.1: Revision history	14
Table 11.1: List of abbreviations	15