



Series 508 Open Frame Socket w/Collet Contacts & Wire Wrap Pins

FEATURES

- Open Frame allows Efficient Utilization of Board Space with Optimized Cooling
- Available 2- and 3-level Wire Wrap Pins
- Compatible with Automatic Insertion Equipment
- Side-to-side and End-to-end Stackable

GENERAL SPECIFICATIONS

- **BODY MATERIAL:** Black UL 94V-0 Glass-filled 4/6 Nylon
- **PIN BODY:** Brass 360 1/2-hard per UNS C36000 ASTM B16/B16M-05
- **PIN BODY PLATING:** 10 μ [0.25 μ] min. Au per MIL-G-45204 or 200 μ [5.08 μ] min. 93/7 Sn/Pb per ASTM B545 -OR- 200 μ [5.08 μ] min. Sn per ASTM B545 Type 1 over 100 μ [2.54 μ] min. Ni per SAE AMS-QQ-N-290B
- **4-FINGER COLLET CONTACT:** BeCu per UNS C17200 ASTM B194-08
- **CONTACT PLATING:** 30 μ [0.76 μ] min. Au per MIL-G-45204 over 50 μ [1.27 μ] min. Ni per SAE AMS-QQ-N-290B
- **CONTACT CURRENT RATING:** 3 amps
- **OPERATING TEMPERATURE:** -67°F to 221°F [-55°C to 105°C] for Sn; -67°F to 257°F [-55°C to 125°C] for Au
- **INSERTION FORCE:** 180g/pin, based on 0.018 [0.46] dia. test lead
- **WITHDRAWAL FORCE:** 90g/pin, based on 0.018 [0.46] dia. test lead
- **NORMAL FORCE:** 140g/pin, based on 0.018 [0.46] dia. test lead
- **ACCEPTS LEADS:** 0.015-0.025 [0.38-0.64] dia., 0.110-0.160 [2.79-4.06] long

MOUNTING CONSIDERATIONS

- **SUGGESTED PCB HOLE SIZE:** 0.045 \pm 0.002 [1.14 \pm 0.05] dia.

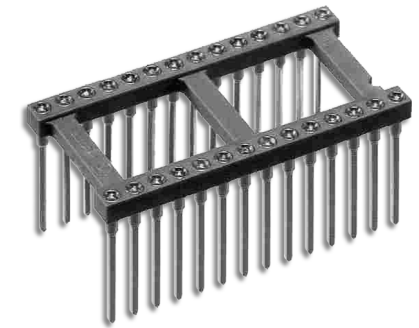
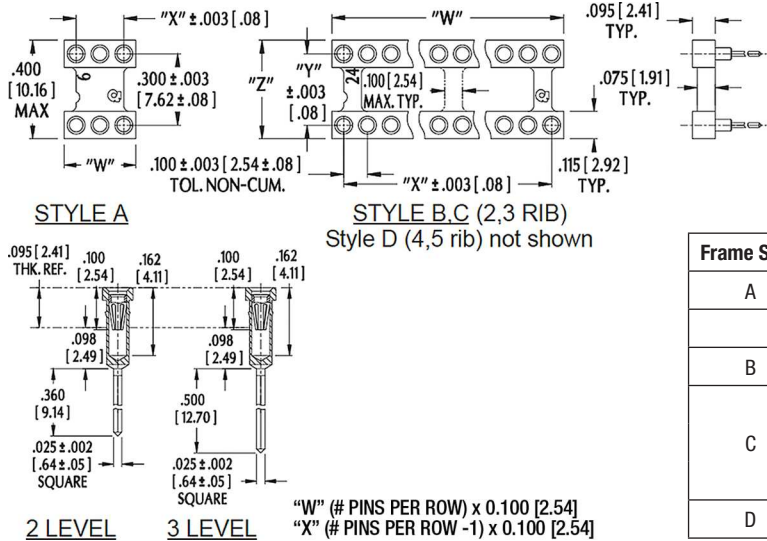

ORDERING INFORMATION

XX-X 508 X XXX

- Plating**
 - 0 = Au Collet, Sn Shell
 - OTL = Au Collet, Sn/Pb Shell
 - 1 = Au Collet & Shell
- Termination**
 - 2 = 2-level Wire Wrap
 - 3 = 3-level Wire Wrap
- Series**
- Row-to-Row Spacing, "Y" Dim.**
 - 3 = 0.300 [7.62]
 - 4 = 0.400 [10.16]
 - 6 = 0.600 [15.24]
 - 9 = 0.900 [22.86]
- No. of Pins**
(See Table)

Frame Style	No. of Ribs	Centers "Y"	Dim. "Z"	No. of Pins
A	1	0.300 [7.62]	0.400 [10.16]	6
		0.300 [7.62]	0.400 [10.16]	8, 14, 16, 18, 20, 24
B	2	0.400 [10.16]	0.500 [12.70]	20, 22
		0.300 [7.62]	0.400 [10.16]	28
C	3	0.400 [10.16]	0.500 [12.70]	24
		0.600 [15.24]	0.700 [17.78]	24, 28, 32, 40, 48
D	4, 5	0.900 [22.86]	1.000 [25.40]	50, 64

ALL DIMENSIONS: INCHES [MILLIMETERS]

ALL TOLERANCES: ± 0.005 [0.13] UNLESS OTHERWISE SPECIFIED

OPEN FRAME COLLET SOCKET w/WIRE WRAP PINS, SEE DATA SHEET 12016

OPEN FRAME SURFACE MOUNT SOCKET, SEE DATA SHEET 12018

OPEN FRAME COLLET CAPACITOR SOCKET w/SOLDER PIN, SEE DATA SHEET 12026

OPEN FRAME COLLET CAPACITOR SOCKET w/WIRE WRAP, SEE DATA SHEET 12027

CONSULT FACTORY FOR OTHER SIZES AND CONFIGURATIONS

CUSTOMIZATION: ARIES SPECIALIZES IN CUSTOM DESIGN AND PRODUCTION. SPECIAL MATERIALS, PLATINGS, SIZES, AND CONFIGURATIONS CAN BE FURNISHED, DEPENDING ON QUANTITY.

ARIES RESERVES THE RIGHT TO CHANGE PRODUCT GENERAL SPECIFICATIONS WITHOUT NOTICE

PRINTOUTS OF THIS DOCUMENT MAY BE OUT-OF-DATE AND SHOULD BE CONSIDERED UNCONTROLLED



ARIES
ELECTRONICS, INC.

2609 Bartram Road • Bristol, PA 19007-6810 USA

TEL 215-781-9956 • FAX 215-781-9845

WWW.ARIESELEC.COM • INFO@ARIESELEC.COM



12017
Rev. 1.2
1 of 1