

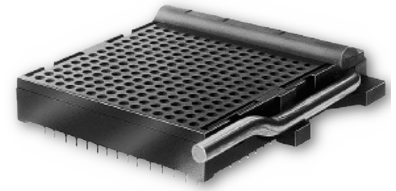

PGA ZIF Test & Burn-in Socket for Any Footprint on Std 8x8 to 21x21 Grid

FEATURES

- Strong Metal Cam Activates Normally-closed Contacts, Preventing Dependency on Plastic for Contact Force
- Handle mounted on Right- or Left-hand Side
- Any Footprint Accepted on Standard 13x13 to 21x21 Grid



GENERAL SPECIFICATIONS

- **SOCKET BODY:** black UL 94V-0 Polyphenylene Sulfide (PPS)
- **CONTACTS:** BeCu 174, 1/2-hard –OR– Spinodal
- **BeCu CONTACT PLATING OPTIONS:** 30μ [0.762μ] min. Au per MIL-G-45204 on contact area, 200μ [5.08μ] min. matte Sn per ASTM B545-97 on solder tail, both over 30μ [0.762μ] min. Ni per QQ-N-290 all over
- **SPINODAL PLATING CONTACT ONLY:** 50μ [1.27μ] min. NiB
- **HANDLE:** Stainless Steel
- **CONTACT CURRENT RATING:** 1 amp
- **OPERATING TEMPERATURES:** -85°F to 257°F [-65°C to 125°C] Au plating, -85°F to 392°F [-65°C to 200°C] NiB (Spinodal)
- **ACCEPTS LEADS:** 0.014-0.026 [0.36-0.66] dia., 0.120-0.290 [3.05-7.37] long

MOUNTING CONSIDERATIONS

- **SUGGESTED PCB HOLE SIZE:** 0.032 ±0.002 [0.81 ±0.05] dia.
- See *PCB FOOTPRINT* below
- Plugs into standard PGA sockets

ORDERING INFORMATION

XXX-PXX XXXXX-1 X

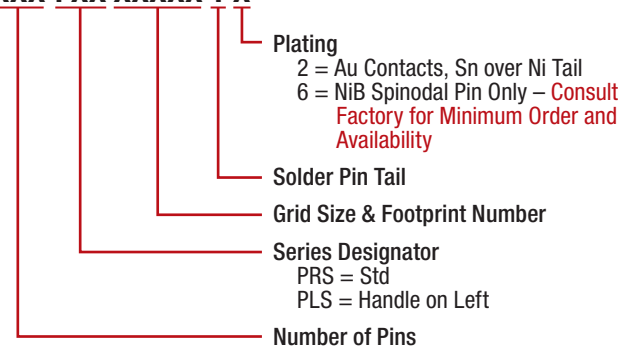

| Grid Size | No. of Pins | Dim. "C" | Dim. "A" | Dim. "B" | Dim. "D" |
|-----------|-------------|---------------|---------------|---------------|---------------|
| 8 x 8 * | 64 | 0.700 [17.78] | 1.695 [43.05] | 1.110 [28.19] | 1.275 [32.39] |
| 9 x 9 | 81 | 0.800 [20.32] | | | |
| 12 x 12 * | 144 | 1.100 [27.94] | 1.894 [48.10] | 1.510 [38.35] | 1.675 [42.55] |
| 13 x 13 | 169 | 1.200 [30.48] | | | |
| 14 x 14 * | 196 | 1.300 [33.02] | 2.094 [53.20] | 1.710 [43.43] | 1.875 [47.63] |
| 15 x 15 | 225 | 1.400 [35.56] | | | |
| 16 x 16 * | 256 | 1.500 [38.10] | 2.294 [58.27] | 1.910 [48.51] | 2.075 [52.71] |
| 17 x 17 | 289 | 1.600 [40.64] | | | |
| 18 x 18 * | 324 | 1.700 [43.18] | 2.494 [63.35] | 2.110 [53.59] | 2.275 [57.79] |
| 19 x 19 | 361 | 1.800 [45.72] | | | |
| 20 x 20 * | 400 | 1.900 [48.26] | 2.694 [68.43] | 2.310 [58.67] | 2.475 [62.87] |
| 21 x 21 | 441 | 2.000 [50.80] | | | |

* Top- and Right-hand Side Rows left out

ALL DIMENSIONS: INCHES [MILLIMETERS]
 ALL TOLERANCES: ±0.005 [0.13] UNLESS OTHERWISE SPECIFIED
 SPECIAL HANDLE REQUIREMENTS: CONSULT FACTORY
 CONSULT FACTORY FOR OTHER SIZES AND CONFIGURATIONS

CUSTOMIZATION: ARIES SPECIALIZES IN CUSTOM DESIGN AND PRODUCTION. SPECIAL MATERIALS, PLATINGS, SIZES, AND CONFIGURATIONS CAN BE FURNISHED, DEPENDING ON QUANTITY.
 ARIES RESERVES THE RIGHT TO CHANGE PRODUCT GENERAL SPECIFICATIONS WITHOUT NOTICE
 PRINTOUTS OF THIS DOCUMENT MAY BE OUT-OF-DATE AND SHOULD BE CONSIDERED UNCONTROLLED



PGA ZIF Test & Burn-in Socket for Any Footprint on Std 8x8 to 21x21 Grid

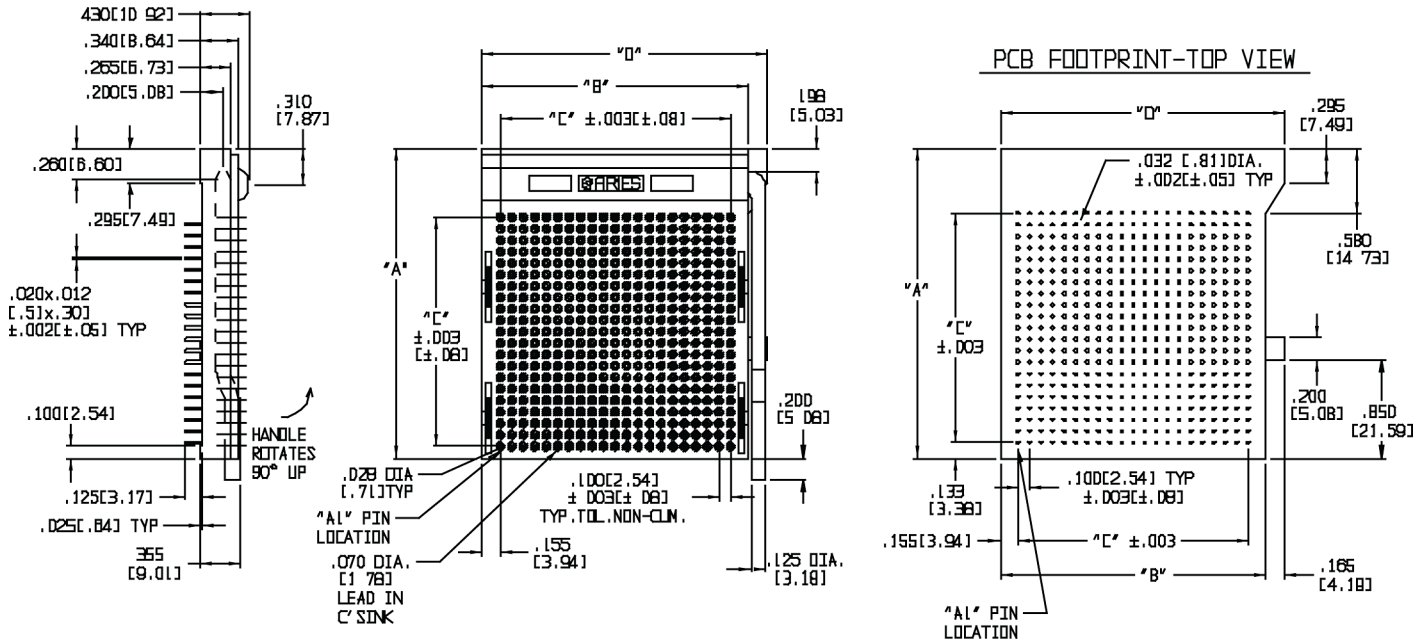

SPECIAL FOOTPRINT INSTRUCTIONS

1. Make a copy of this worksheet
2. Fill-in circles for footprint desired using the key below
3. Fill-in the information below, including Series and Plating options. See Ordering Information above
4. Send worksheet to Aries for prompt quote

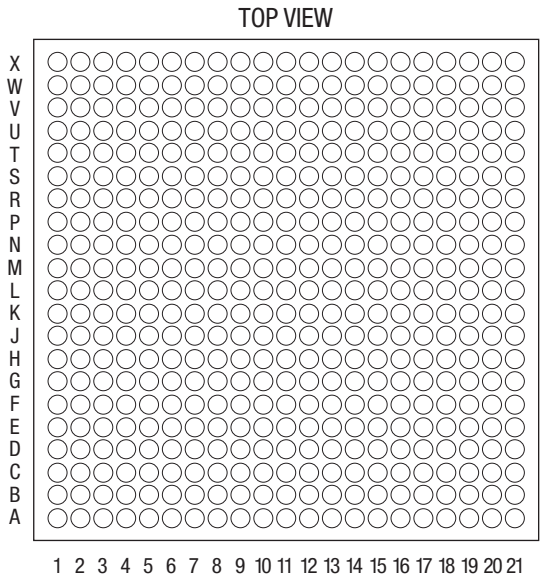

KEY

- = no pin
- = pin
- X = plug hole

COMPANY NAME _____

ADDRESS _____

CITY _____

REQUESTED BY _____

PHONE _____

DATE _____

TOTAL NUMBER OF PINS _____

SERIES (circle one) PRS PLS

PLATING (circle one) 2 6

ALL DIMENSIONS: INCHES [MILLIMETERS]
 ALL TOLERANCES: ±0.005 [0.13] UNLESS OTHERWISE SPECIFIED
 SPECIAL HANDLE REQUIREMENTS: CONSULT FACTORY
 CONSULT FACTORY FOR OTHER SIZES AND CONFIGURATIONS

CUSTOMIZATION: ARIES SPECIALIZES IN CUSTOM DESIGN AND PRODUCTION. SPECIAL MATERIALS, PLATINGS, SIZES, AND CONFIGURATIONS CAN BE FURNISHED, DEPENDING ON QUANTITY.
 ARIES RESERVES THE RIGHT TO CHANGE PRODUCT GENERAL SPECIFICATIONS WITHOUT NOTICE
 PRINTOUTS OF THIS DOCUMENT MAY BE OUT-OF-DATE AND SHOULD BE CONSIDERED UNCONTROLLED



2609 Bartram Road • Bristol, PA 19007-6810 USA
 TEL 215-781-9956 • FAX 215-781-9845
 WWW.ARIESELEC.COM • INFO@ARIESELEC.COM

