

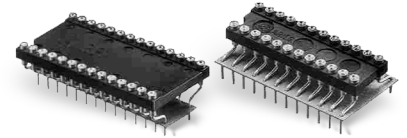

P/Ns 1106396 & 1107254 Row-to-Row DIP Adapter Socket

FEATURES

- Adapter Socket allows the use of 0.300 [7.62] center devices when the PCB is drilled on 0.600 [15.24] centers and vice versa, giving the flexibility of using 0.600 [15.24] or 0.300 [7.62] center devices in the same application.



GENERAL SPECIFICATIONS

- **SOCKET BODY:** Black UL 94V-0 Glass-filled 4/6 Nylon
- **PIN BODY:** Brass 360 1/2-hard per UNS C36000, ASTM B16/B16M
- **PIN BODY PLATING:** 200µ [5.08µ] min. Sn per ASTM B545 Type 1 over 100µ [2.54µ] Ni per SAE AMS-QQ-N-290B
- **4-FINGER COLLET CONTACT:** BeCu per UNS C17200, ASTM B194-08
- **CONTACT PLATING:** 30µ [0.762µ] min. Au per MIL-G-45204 over 50µ [1.27µ] min. Ni per SAE AMS-QQ-N-290
- **CONTACT CURRENT RATING:** 3 amps
- **OPERATING TEMPERATURE:** 221°F [105°C]
- **INSERTION FORCE:** 180g/pin; based on 0.018 [0.46] dia. test lead
- **WITHDRAWAL FORCE:** 90g/pin; based on 0.018 [0.46] dia. test lead
- **NORMAL FORCE:** 140g/pin; based on 0.018 [0.46] dia. test lead
- **ACCEPTS LEADS:** 0.015-0.025 [0.38-0.64] dia., 0.110-0.150 [2.79-3.81] long

ORDERING INFORMATION

**For 0.300 [7.62] DIP to 0.600 [15.24] PCB
1106396-XX**

No. of Pins – (6 thru 40)

**For 0.600 [15.24] DIP to 0.300 [7.62] PCB
1107254-XX**

No. of Pins – (6 thru 40)

MOUNTING CONSIDERATIONS

- **SUGGESTED PCB HOLE SIZE:** 0.035 ±0.002 [0.89 ±0.05] dia.

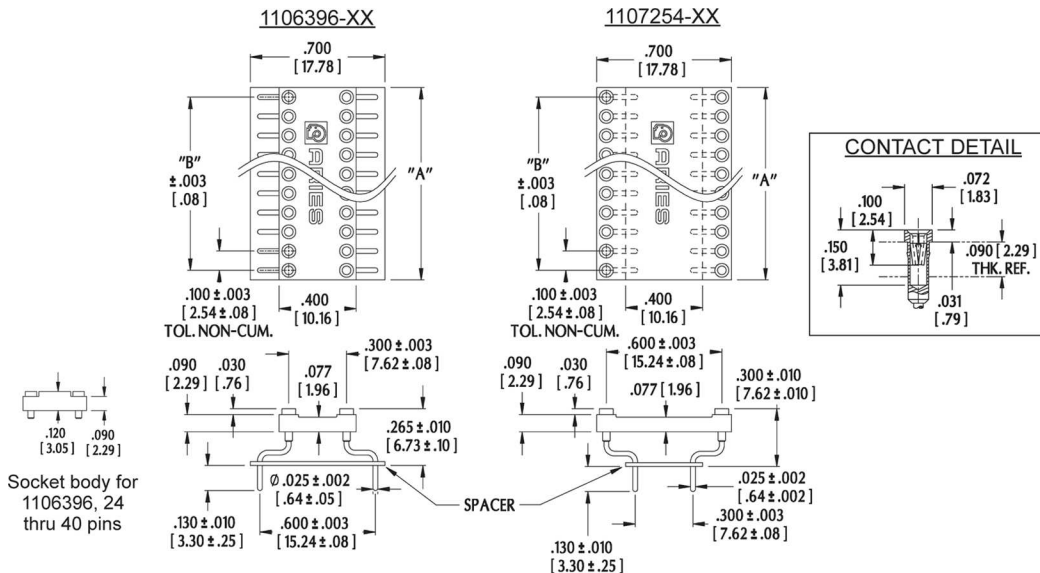

ALL DIMENSIONS: INCHES [MILLIMETERS]

**ALL TOLERANCES: ±0.005 [0.13] UNLESS OTHERWISE SPECIFIED
CONSULT FACTORY FOR OTHER SIZES AND CONFIGURATIONS**

**CUSTOMIZATION: ARIES SPECIALIZES IN CUSTOM DESIGN AND PRODUCTION.
SPECIAL MATERIALS, PLATINGS, SIZES, AND CONFIGURATIONS CAN BE
FURNISHED, DEPENDING ON QUANTITY.**

**ARIES RESERVES THE RIGHT TO CHANGE PRODUCT GENERAL SPECIFICATIONS
WITHOUT NOTICE**

**PRINTOUTS OF THIS DOCUMENT MAY BE OUT-OF-DATE AND SHOULD BE
CONSIDERED UNCONTROLLED**



ARIES
ELECTRONICS, INC.

2609 Bartram Road • Bristol, PA 19007-6810 USA
TEL 215-781-9956 • FAX 215-781-9845
WWW.ARIESELEC.COM • INFO@ARIESELEC.COM



12030
Rev. 2.1
1 of 1