



# Series 501 Strip-Line™ Socket Strip w/Bifurcated Contacts & Wire Wrap Pins

## FEATURES

- Mount Liquid Crystal Displays or Other High Pin-count or Odd-centered Components
- Available in Several Sizes with Bifurcated Contacts in Wire Wrap or Solder Pin Tails Consult Data Sheet 12008 for Solder Pin Tails
- Optional Spacer for Mounting on 0.300 [7.62], 0.600 [15.24], 0.900 [22.86], 1.100 [27.94], and 1.300 [33.02] Centers Consult factory for other sizes.

## GENERAL SPECIFICATIONS

- BODY: black UL 94V-0 glass-filled 4/6 Nylon
- PIN: Grade A Phosphor Bronze per QQ-B-750
- OPTIONAL SPACER: FR-4 0.032 [0.81] thick
- PIN PLATING: "11" 10μ [0.25μ] min. Au per MIL-G-45204 over 50μ [1.27μ] Dim. "L" min. Ni per SAE AMS-QQ-N-290B; "10" 200μ [5.08μ] min. matte Sn per ASTM B545-97(2004)e1 over 50μ [1.27μ] min. Ni per SAE AMS-QQ-N-290B; "10TL" 200μ [5.08μ] min. 90/10 Sn/Pb per MIL-T-10727 Type 1 over 50μ [1.27μ] min. Ni per SAE AMS-QQ-N-290B
- CURRENT RATING: 1 amp
- OPERATING TEMPERATURE: -67°F to 221°F [-55°C to 105°C] Sn & Sn/Pb plating; -67°F to 257°F [-55°C to 125°C] Au
- INSERTION FORCE: 110g/pin average
- WITHDRAWAL FORCE: 75g/pin average
- ACCEPTS: flat leads up to 0.014 x 0.020 wide [0.36-0.51], Round Leads up to 0.020 [0.51] dia.
- SOCKET ACCEPTS: lead lengths from seating plane 0.080-0.160 [2.03-4.06]

## MOUNTING CONSIDERATIONS

- SUGGESTED PCB HOLE SIZE: 0.045 ±0.002 [0.114 ±0.05] dia.

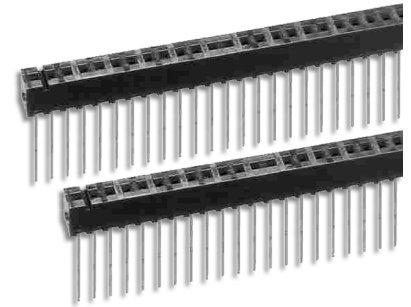

## ORDERING INFORMATION

**XX-0 501-X XXX**

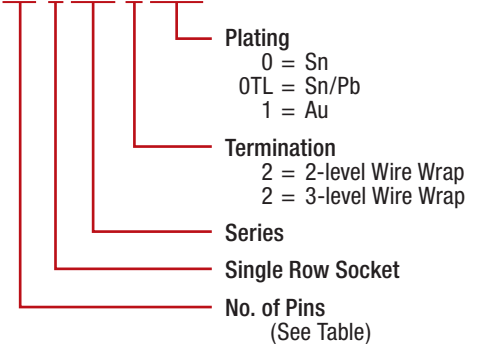

	Dim. "L"
2-level Wire Wrap	0.420 [10.67]
3-level Wire Wrap	0.690 [17.52]

No. of Pins	No. of Grooves
20	2
25	2
30	2
34	2
40	2

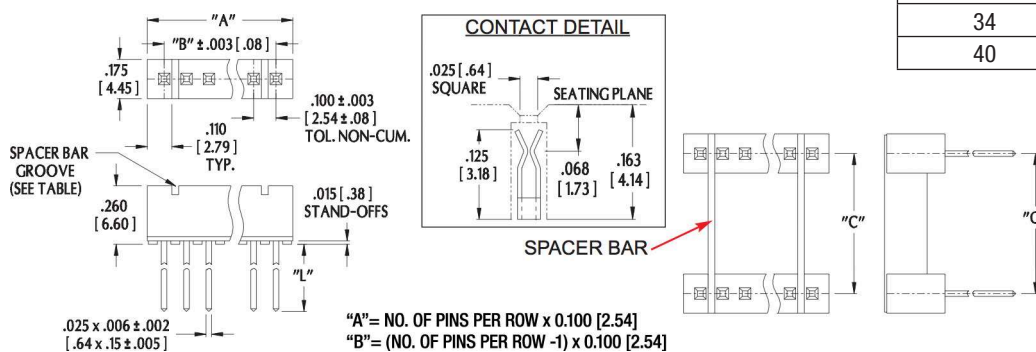

ALL DIMENSIONS: INCHES [MILLIMETERS]  
 ALL TOLERANCES: ±0.005 [0.13] UNLESS OTHERWISE SPECIFIED  
 FOR STRIP-LINE SOCKETS w/SOLDER PIN TAILS, SEE DATA SHEETS 12008  
 CONSULT FACTORY FOR OTHER SIZES AND CONFIGURATIONS

CUSTOMIZATION: ARIES SPECIALIZES IN CUSTOM DESIGN AND PRODUCTION. SPECIAL MATERIALS, PLATINGS, SIZES, AND CONFIGURATIONS CAN BE FURNISHED, DEPENDING ON QUANTITY.  
 ARIES RESERVES THE RIGHT TO CHANGE PRODUCT GENERAL SPECIFICATIONS WITHOUT NOTICE  
 PRINTOUTS OF THIS DOCUMENT MAY BE OUT-OF-DATE AND SHOULD BE CONSIDERED UNCONTROLLED



2609 Bartram Road • Bristol, PA 19007-6810 USA  
 TEL 215-781-9956 • FAX 215-781-9845  
 WWW.ARIESELEC.COM • INFO@ARIESELEC.COM

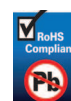

12009  
 Rev. 5.1  
 1 of 1