



# Series 800 Vertisocket™ w/Collet Contacts for Vertical Mounting

## FEATURES

- DIP Packaging of LEDs, Incandescent Lamps, DIP Switches, Test Points, etc.
- Variations of Mounting Positions provide Exceptional Design Freedom
- Accepts Standard LEDs and Incandescent Displays as well as 0.500 [21.70] and 0.600 [15.24] Tall Displays

## GENERAL SPECIFICATIONS

- **BODY MATERIAL:** black UL 94V-0 glass-filled 4/6 Nylon
- **SPACER:** fish paper
- **PIN BODY:** brass 360 1/2-hard per UNS C36000 ASTM B16/B16M-05
- **PIN BODY PLATING:** 200μ [5.08μ] min. 93/7 Sn/Pb per ASTM B545 –OR– 200μ [5.08μ] min. Sn per ASTM B545 Type 1 over 100μ [2.54μ] min. Ni per SAE AMS-QQ-N-290B
- **4-FINGER COLLET CONTACT:** BeCu per UNS C17200 ASTM B194-08
- **CONTACT PLATING:** 30μ [0.76μ] min. Au per MIL-G-45204 over 50μ [1.27μ] min. Ni per SAE AMS-QQ-N-290B
- **CONTACT CURRENT RATING:** 3 amps
- **OPERATING TEMPERATURE:** 221°F [105°C]
- **INSERTION FORCE:** 180g/pin, based on 0.018 [0.46] dia. test lead
- **WITHDRAWAL FORCE:** 90g/pin, based on 0.018 [0.46] dia. test lead
- **NORMAL FORCE:** 140g/pin, based on 0.018 [0.46] dia. test lead
- **ACCEPTS LEADS:** 0.015-0.025 [0.38-0.64] in dia., 0.110-0.150 [2.79-3.81] long

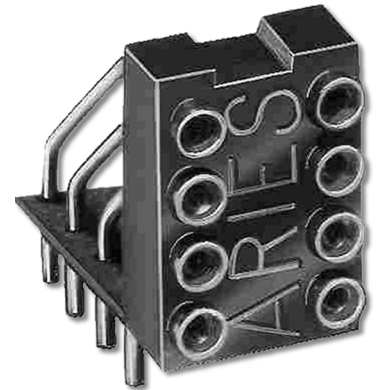

## MOUNTING CONSIDERATIONS

- **SUGGESTED PCB HOLE SIZE:** 0.035 ±0.002 [0.89 ±0.05] dia.

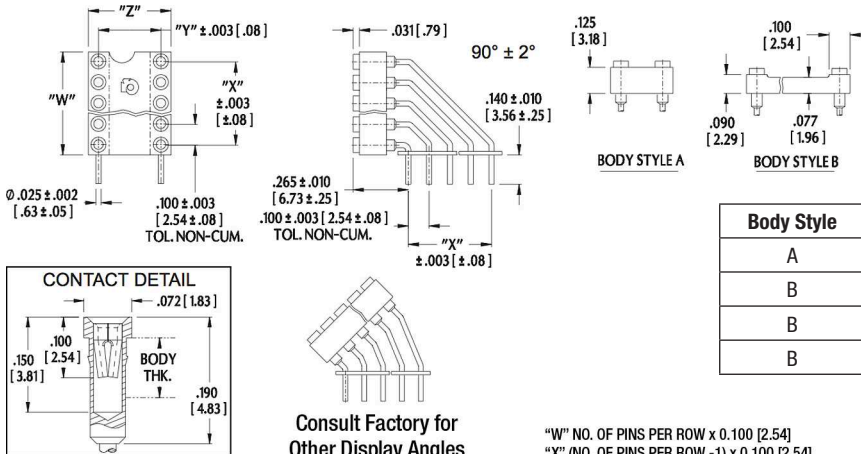

## ORDERING INFORMATION

**XX-X810-90 C XX**

- Optional Pin Body Plating  
TL = Sn/Pb
- Collet Contacts
- 90° Display Angle
- Device Footprint, Dim. "Y"  
2810 = 0.200 [5.08]  
810 = 0.300 [7.62]  
4810 = 0.400 [10.16]  
6810 = 0.600 [15.24]
- Pin Count & Spacing  
(See Table)

Body Style	Centers "Y"	Dim. "Z"	Available Sizes
A	0.200 [5.08]	0.300 [7.62]	8, 10
B	0.300 [7.62]	0.400 [10.16]	8, 10, 12, 14, 16
B	0.400 [10.16]	0.500 [12.70]	8, 10
B	0.600 [15.24]	0.700 [12.78]	8, 10, 12, 14, 16

ALL DIMENSIONS: INCHES [MILLIMETERS]  
ALL TOLERANCES: ±0.005 [0.13] UNLESS OTHERWISE SPECIFIED  
FOR HORIZONTAL MOUNTING, SEE DATA SHEET 13005  
CONSULT FACTORY FOR OTHER SIZES AND CONFIGURATIONS

CUSTOMIZATION: ARIES SPECIALIZES IN CUSTOM DESIGN AND PRODUCTION.  
SPECIAL MATERIALS, PLATINGS, SIZES, AND CONFIGURATIONS CAN BE  
FURNISHED, DEPENDING ON QUANTITY.

ARIES RESERVES THE RIGHT TO CHANGE PRODUCT GENERAL SPECIFICATIONS  
WITHOUT NOTICE

PRINTOUTS OF THIS DOCUMENT MAY BE OUT-OF-DATE AND SHOULD BE  
CONSIDERED UNCONTROLLED



**ARIES**  
ELECTRONICS, INC.

2609 Bartram Road • Bristol, PA 19007-6810 USA  
TEL 215-781-9956 • FAX 215-781-9845  
WWW.ARIESELEC.COM • INFO@ARIESELEC.COM

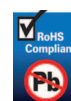

13004  
Rev. 6.1  
1 of 1