

# DATA SHEET

WIRELESS COMPONENTS

Ceramic Chip Antenna

ANTB010L04R2400A

2.4 - 2.5 GHz

8010 Series



FEATURES

- Compact size
- Omni-directional radiation
- Tape & reel automatic mounting
- Reflow process compatible
- RoHS compliant

APPLICATIONS

- 2.4 GHz WiFi device
- Bluetooth gadget
- Zigbee device
- ISM band equipment

ORDERING INFORMATION

All part numbers are identified by the series, packing type, material, size, antenna type, working frequency and packing quantity.

**PART NUMBER**

**ANT 8010 L L04 R 2400A**  
(1) (2) (3) (4) (5) (6)

---

**(1) PRODUCT**

ANT = Antenna

---

**(2) SIZE**

8010=8.0x1.0 mm

---

**(3) ANTENNA TYPE**

L,F,A = Chip Antenna

---

**(4) SERIAL NO.**

L04

---

**(5) PACKING STYLE**

R = Tape and Reel

---

**(6) WORKING FREQUENCY**

2400 = 2.4 - 2.5 GHz

---

**PHYCOMP CTC**

CAN4311781042453K

---

**I2NC**

431178104245

---

**SPECIFICATION**

Table 1

DESCRIPTION	VALUE
Working Frequency	2.4 - 2.5 GHz
Bandwidth	170 MHz (Typ.)
Polarization	Linear
Azimuth Beamwidth	Omni-directional
Peak Gain	5.46 dBi (Typ.)
Impedance	50 ohm
Operating Temperature	- 40~105 °C
Maximum Power	1 W
Termination	Ni / Sn (Environmentally-Friendly Leadless)
Resistance to Soldering Heats	260°C , 10sec.

**NOTE**

1. The specification is defined on Yageo evaluation board

**DIMENSIONS**

Table 2 Machinical Dimension

	DIMENSION
L (mm)	1.00 ±0.10
W (mm)	8.00 ±0.10
T (mm)	1.00 ±0.10
C (mm)	0.90 ±0.15

**OUTLINES**

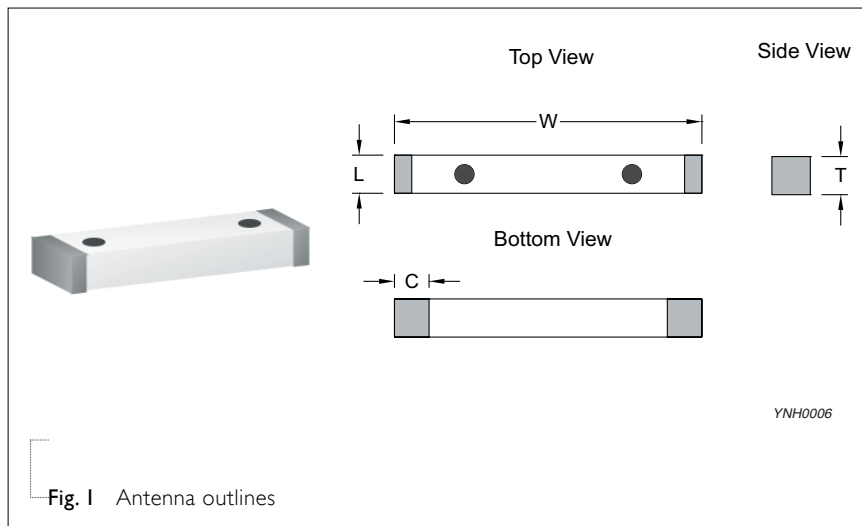

**REFERENCE DESIGN OF EVALUATION BOARD**

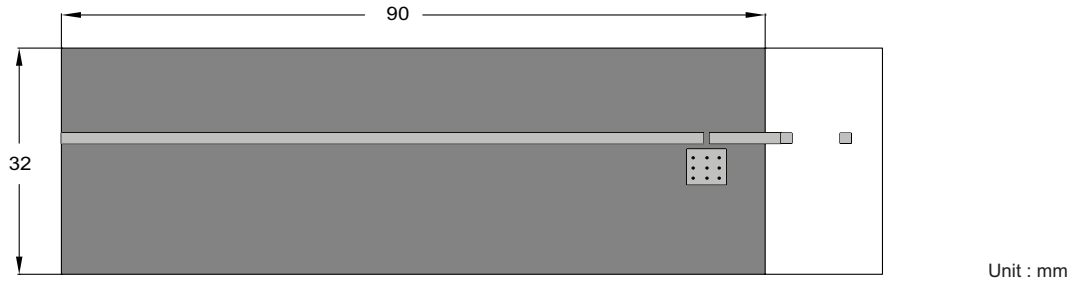

**Fig. 3** Outlook and dimension of evaluation board

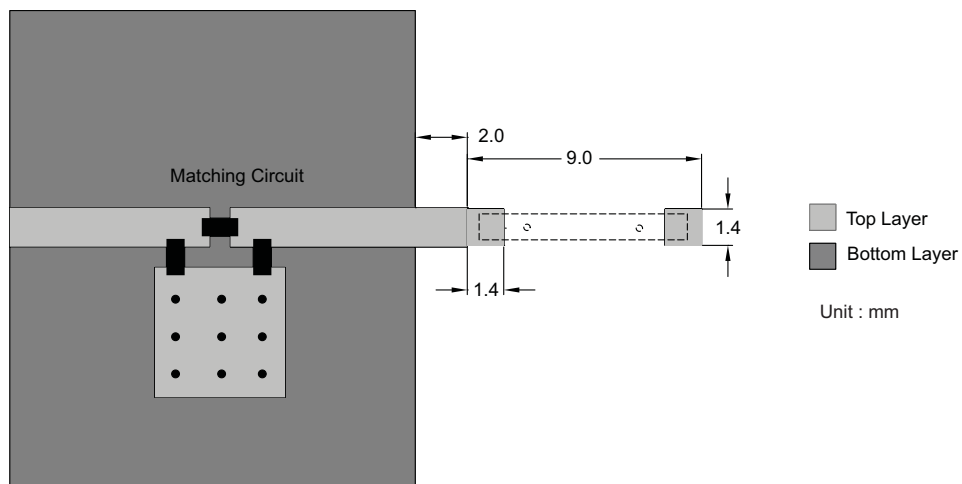

**Fig. 4** Details of soldering pad

YNH0007

**ELECTRICAL PERFORMANCES**

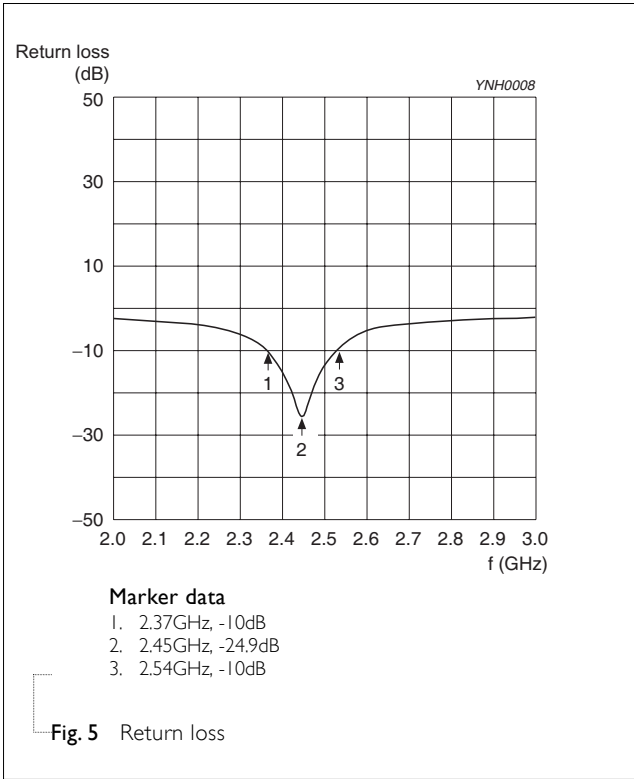

**Fig. 5** Return loss

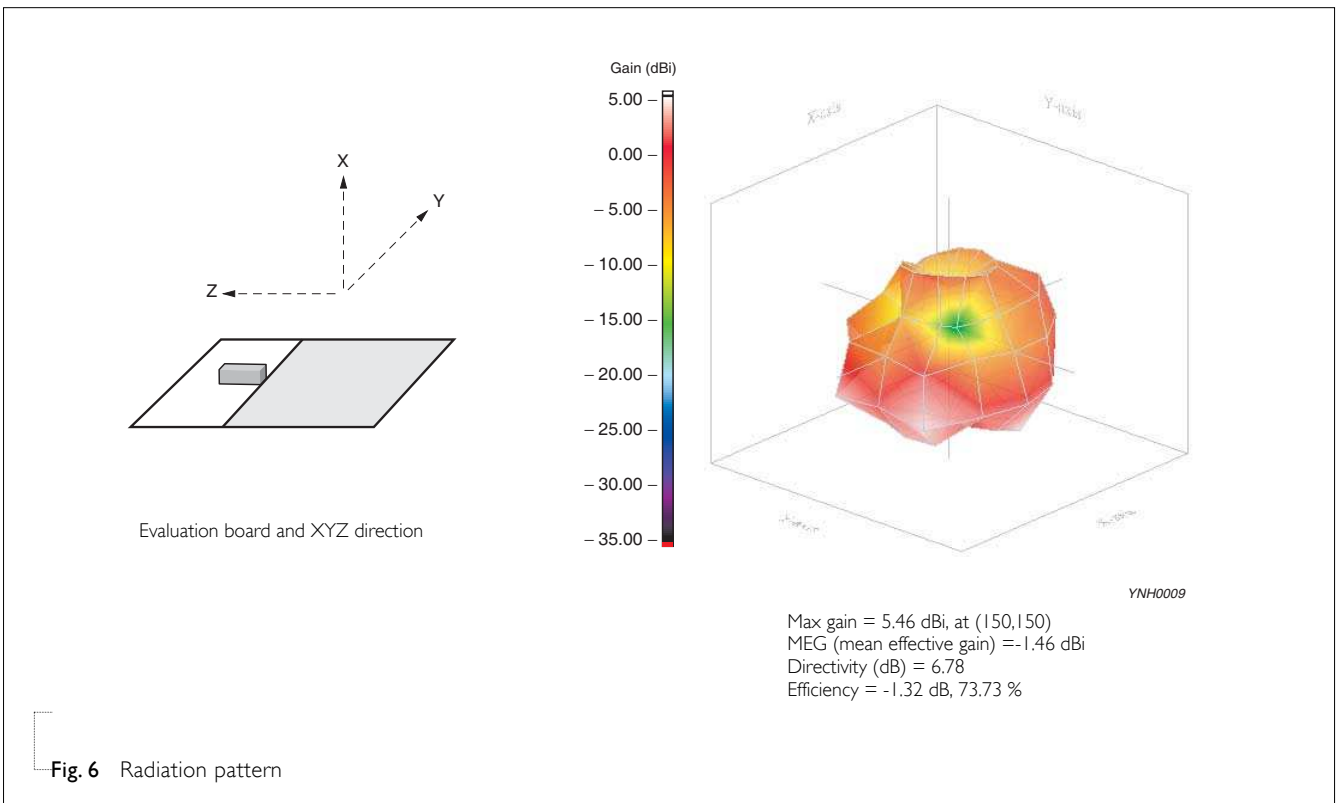

**Fig. 6** Radiation pattern

REVISION HISTORY

REVISION	DATE	CHANGE NOTIFICATION	DESCRIPTION
Version 0	Feb. 04, 2013	-	- New datasheet for SMD type antenna, 2.45 GHz application, 8010 series