

NOTES: UNLESS OTHERWISE SPECIFIED

1. CONSTRUCTION:
 HOUSING & PLUNGER & SLIDE: MOLDED NYLON 6,6.
 AVAILABLE IN TEN COLORS.
 CONTACT NEEDLE: STAINLESS STEEL.
 BANANA SOCKER: 360 1/2 HD. BRASS.
 COMPRESSION SPRING: STAINLESS STEEL.

2. PERFORMANCE:
 MAXIMUM CURRENT: 500 mA
 MAXIMUM VOLTAGE: 300 V
 MAXIMUM TEMPERATURE: 200°F (93°C)

2. FEATURES:
 NEEDLE PIERCES WIRE $\phi 0.050$ [$\phi 1.27$] TO $\phi 0.150$ [$\phi 3.81$].
 DOUBLE BANANA SOCKET.
 ACCEPTS SHROUDED AND UNSHROUDED BANANA PLUGS.

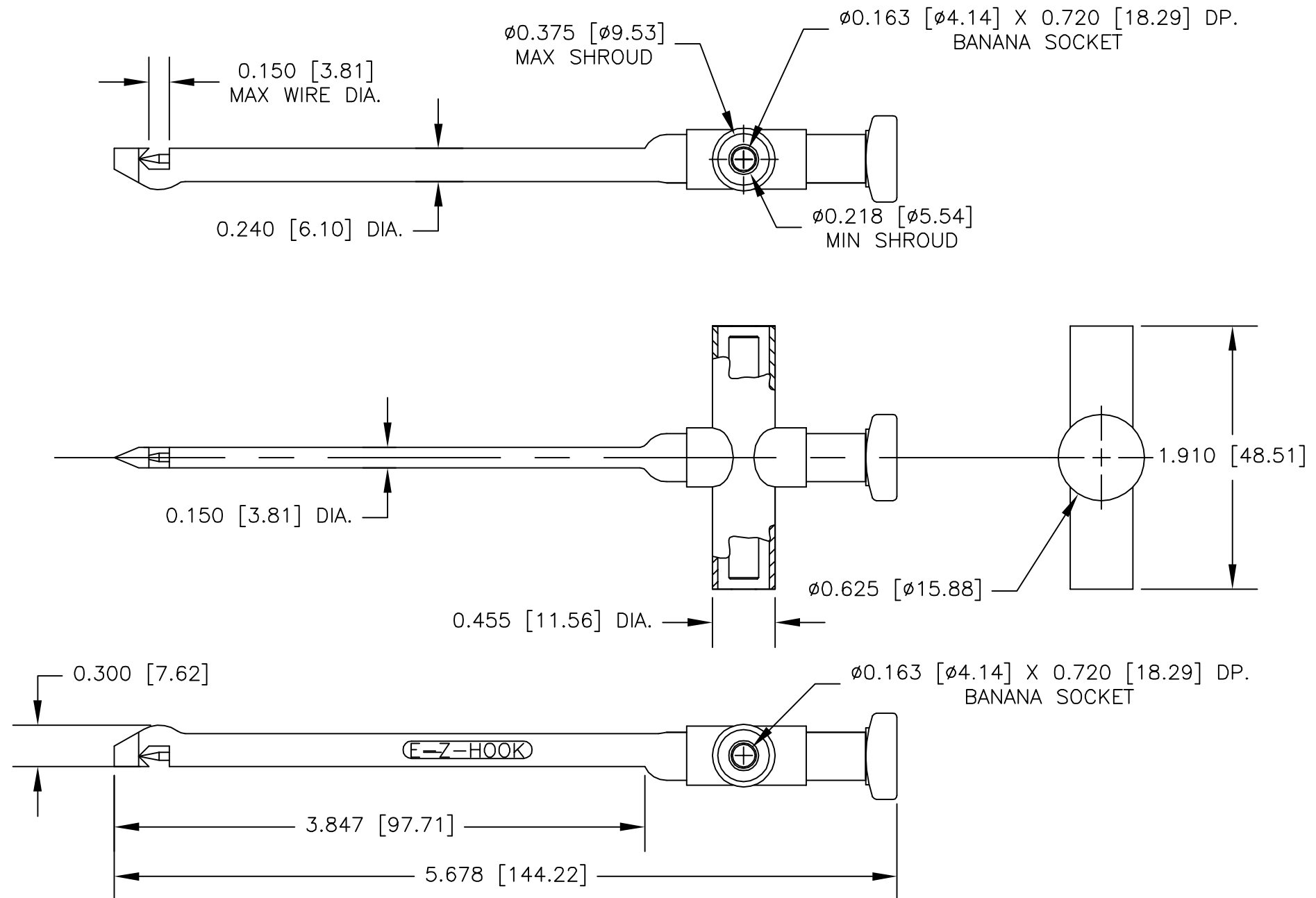

LTR	DESCRIPTION	DATE	APPROVE

UNLESS OTHERWISE SPECIFIED DIMENSIONS ARE IN INCHES TOLERANCES ARE: FRACTIONS DECIMALS ANGLES ± .XX ± ± .XXX ±		CONTRACT NO.		E-Z-HOOK DIVISION OF TEKTEST INC. ARCADIA, CA 91006 U.S.A.	
MATERIAL SEE NOTE.		APPROVALS DRAWN R.L. 6/09			
FINISH SEE NOTE.		APPROVED BY		DESCRIPTION E-Z-MACRO HOOK INSULATION-PIERCING	
NEXT ASSY	USED ON	DO NOT SCALE DRAWING		SIZE B	CODE IDENT NO. 08505
APPLICATION		SCALE 1:1		DRAWING NO. XEL	REV
				SHEET 1 OF 1	