

NOTES: UNLESS OTHERWISE SPECIFIED

1. CONSTRUCTION:  
 HOUSING & PLUNGER: MOLDED NYLON TYPE 6,6. AVAILABLE IN TEN COLORS.  
 CONTACT BLADE: NICKEL SILVER ALLOY CA 770.  
 SPRING: STAINLESS STEEL TYPE 302.

2. PERFORMANCE:  
 MAXIMUM CURRENT: 10.9 AMPS WITH A 76° TEMPERATURE RISE.  
 MAXIMUM VOLTAGE: 2.4 KV  
 MAXIMUM TEMPERATURE: 200°F (93°C)

3. FEATURES:  
 HOOK PIERCES WIRE UP TO  $\phi 0.140$ " [3.56].  
 FIELD SERVICEABLE.

LTR		REVISIONS	DATE	APPROVED

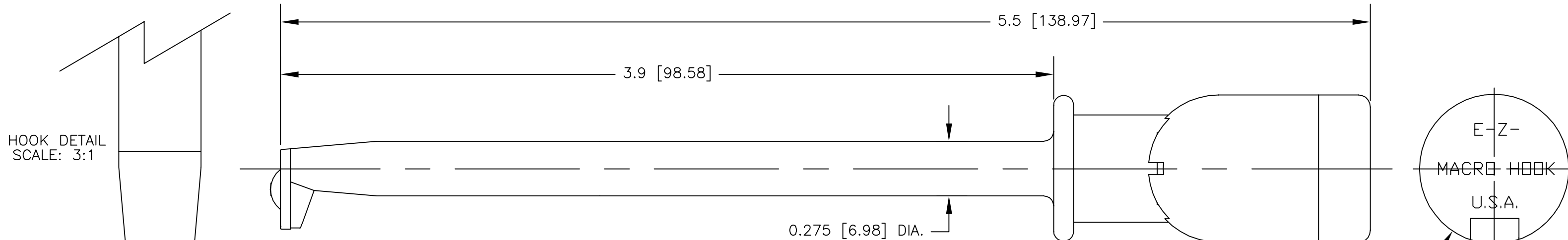
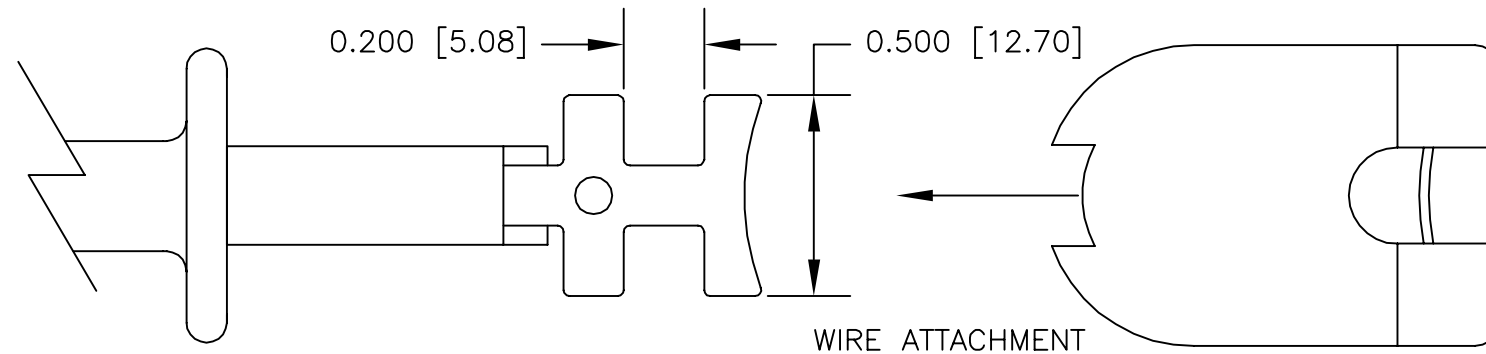

HOOK DETAIL  
 SCALE: 3:1

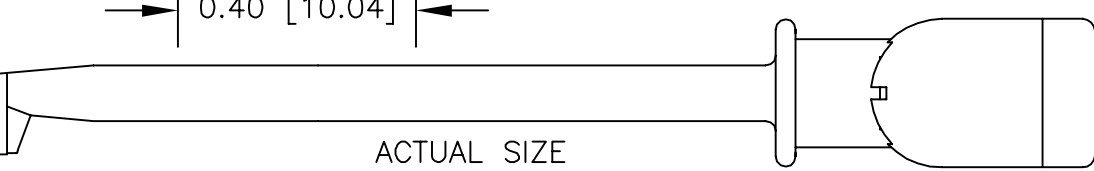
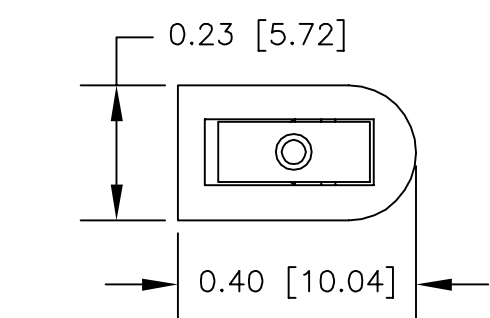
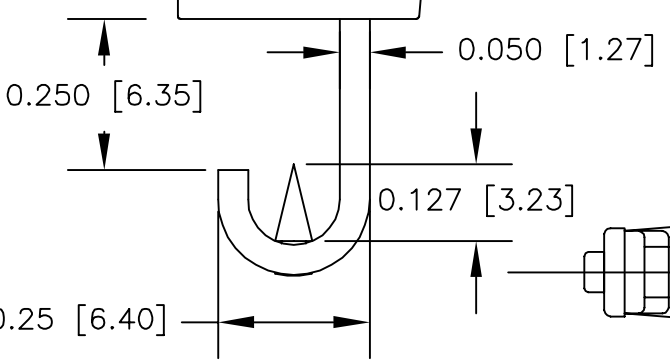

		UNLESS OTHERWISE SPECIFIED DIMENSIONS ARE IN INCHES TOLERANCES ARE: FRACTIONS DECIMALS ANGLES $\pm$ .XX $\pm$ $\pm$ $\pm$ .XXX $\pm$	CONTRACT NO.		<b>E-Z-HOOK</b> DIVISION OF TEKTEST INC. ARCADIA, CA 91006 U.S.A.
			APPROVALS	DATE	
		MATERIAL SEE NOTE.	DRAWN	R.L. 6/09	DESCRIPTION E-Z-MACRO HOOK. INSULATION-PIERCING, LONG
			APPROVED BY		
		FINISH SEE NOTE.			SIZE <b>B</b> CODE IDENT NO. <b>08505</b> DRAWING NO. <b>XJL</b> REV.
NEXT ASSY	USED ON				SCALE 2:1 SHEET 1 OF 1
APPLICATION		DO NOT SCALE DRAWING			