

NOTES: UNLESS OTHERWISE SPECIFIED

LTR	DESCRIPTION	REVISIONS		DATE	APPROVED

- CONSTRUCTION:
 - HOUSING & PLUNGER: MOLDED NYLON DUPONT ZYTEL 101L 10/11% GLASS FILLED. AVAILABLE IN TEN COLORS.
 - CONTACT BLADE: STAINLESS STEEL, 304 FULL HARD. PASSIVATED PER MIL-S-5002 TYPE 1.
 - COMPRESSION SPRING: STAINLESS STEEL 302, .009" DIA. WIRE PASSIVATED.

- PERFORMANCE:
 - MAXIMUM CURRENT: XX
 - MAXIMUM VOLTAGE: XX
 - MAXIMUM TEMPERATURE: XX

- FEATURES:
 - HOOK FITS COMPONENTS UP TO $\phi 0.050$ " [1.27].
 - PINS EXIT PLUNGER ON EITHER SIDE.
 - PINS PERMIT CONNECTION TO 0.025" [0.64] SQ. OR $\phi 0.030$ " [0.76] SOCKETS.

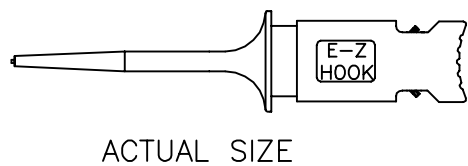
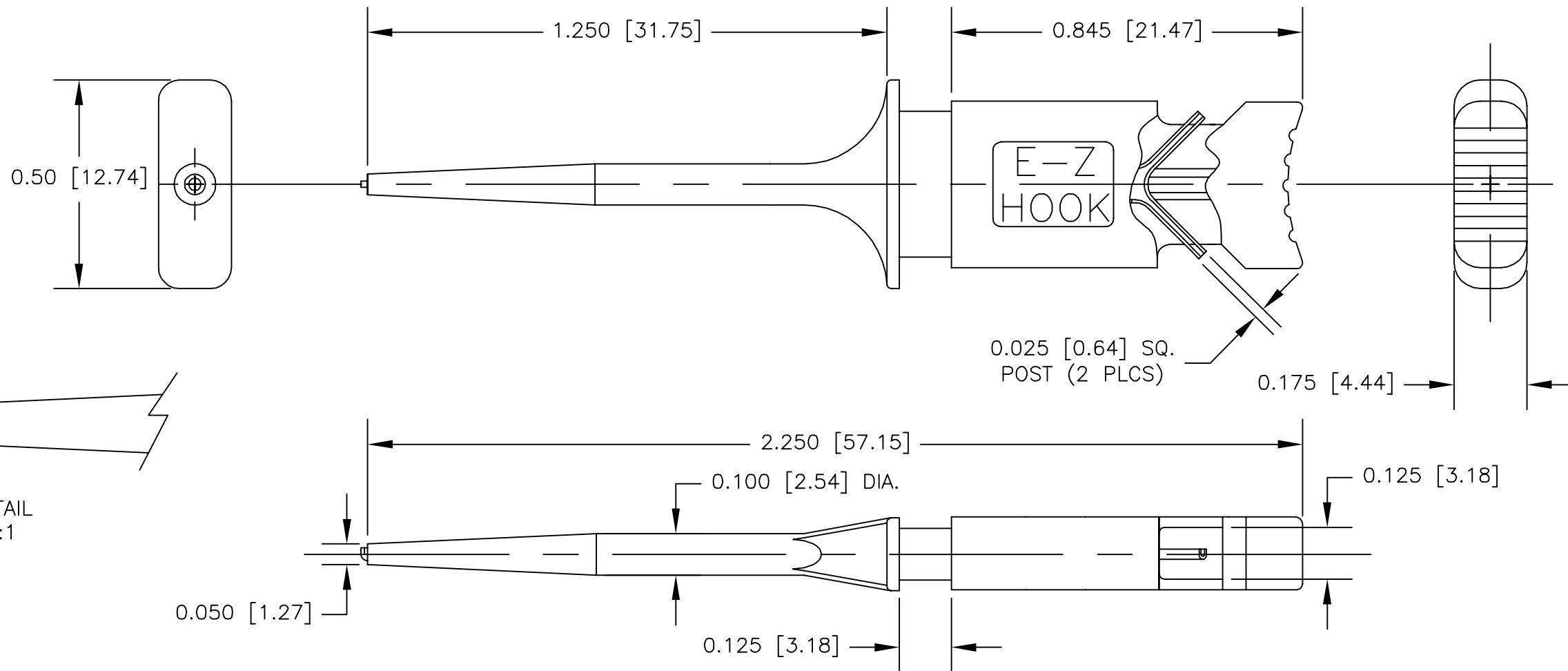

		UNLESS OTHERWISE SPECIFIED DIMENSIONS ARE IN INCHES TOLERANCES ARE: FRACTIONS DECIMALS ANGLES ± .XX ± ± .XXX ±	CONTRACT NO.		E-Z-HOOK DIVISION OF TEKTEST INC. ARCADIA, CA 91006 U.S.A.
			APPROVALS	DATE	
		MATERIAL SEE NOTE.	DRAWN R.L.	6/09	DESCRIPTION E-Z-MICRO HOOK GRIPPER TEST CONNECTOR
		FINISH SEE NOTE.	APPROVED BY		SIZE CODE IDENT NO. DRAWING NO. REV. B 08505 XKM
NEXT ASSY	USED ON				
APPLICATION		DO NOT SCALE DRAWING			SCALE 3:1 SHEET 1 OF 1