

NOTES: UNLESS OTHERWISE SPECIFIED

| LTR | DESCRIPTION | REVISIONS |             | DATE | APPROVED |
|-----|-------------|-----------|-------------|------|----------|
|     |             | NO.       | DESCRIPTION |      |          |
|     |             |           |             |      |          |

- CONSTRUCTION:  
HOUSING & PLUNGER: MOLDED NYLON TYPE 6,6. AVAILABLE IN TEN COLORS.  
CONTACT BLADE: BERYLLIUM COPPER PER QQ-C-533. GOLD PLATED PER MIL-G-45204.4001 0.00001" [0.000254] THICK MINIMUM.  
SPRING: STAINLESS STEEL TYPE 302.
- PERFORMANCE:  
MAXIMUM CURRENT: 6.9 AMPS WITH 76° TEMPERATURE RISE.  
MAXIMUM VOLTAGE: 2.0 KV  
MAXIMUM TEMPERATURE: 175°F (79°C)
- FEATURES:  
HOOK FITS COMPONENTS UP TO  $\phi 0.040$ " [1.01]  
FIELD SERVICEABLE.

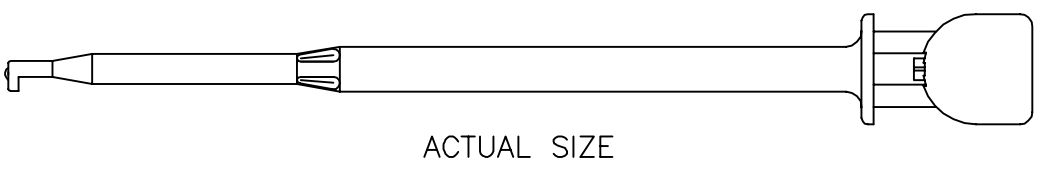
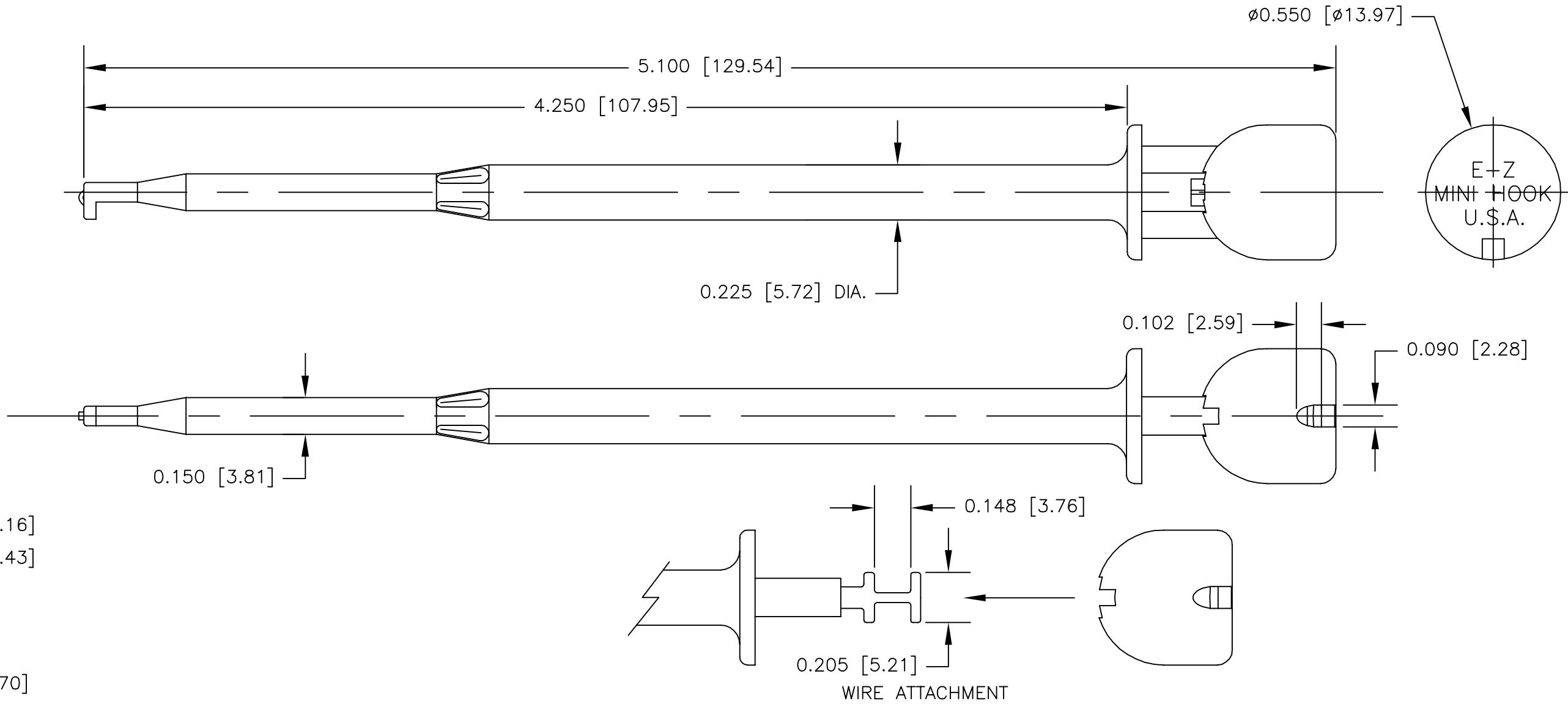
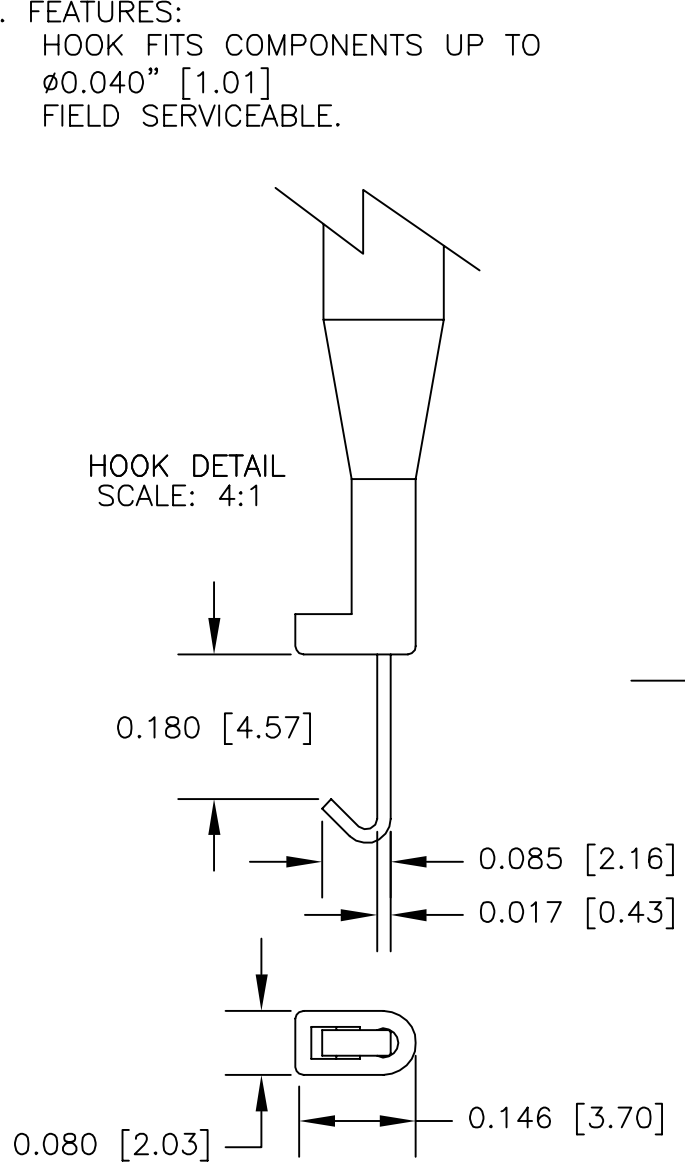

|             |         |   |              |      |  |
|-------------|---------|---|--------------|------|--|
|             |         | UNLESS OTHERWISE SPECIFIED<br>DIMENSIONS ARE IN INCHES<br>TOLERANCES ARE:<br>FRACTIONS DECIMALS ANGLES<br>± .XX ± ±<br>.XXX ± | CONTRACT NO. |      | <b>E-Z-HOOK</b> DIVISION OF TEKTEST INC.<br>ARCADIA, CA 91006 U.S.A. |
|             |         |   | APPROVALS    | DATE |  |
|             |         | MATERIAL<br>SEE NOTE.   | DRAWN R.L.   | 6/09 | DESCRIPTION<br>E-Z-MINI-HOOK TEST<br>CONNECTOR                       |
|             |         | FINISH<br>SEE NOTE.   | APPROVED BY  |      |  |
| NEXT ASSY   | USED ON |   |              |      | SIZE <b>B</b>  |
| APPLICATION |         | DO NOT SCALE DRAWING  |              |      | CODE IDENT NO. <b>08505</b>  |
|             |         |   |              |      | DRAWING NO. XL1  |
|             |         |   |              |      | SCALE 2:1  |
|             |         |   |              |      | SHEET 1 OF 1   |