

NOTES: UNLESS OTHERWISE SPECIFIED

- CONSTRUCTION:
 HOUSING & PLUNGER: MOLDED NYLON TYPE 6,6.
 AVAILABLE IN TEN COLORS.
 CONTACT BLADE: BERYLLIUM COPPER PER QQ-C-533. GOLD PLATED PER MIL-G-45204 B TYPE 1 0.0001" [0.00254] THICK MINIMUM.
 SPRING: STAINLESS STEEL TYPE 302.

- PERFORMANCE:
 MAXIMUM CURRENT: 4.4 AMPS WITH 76° TEMPERATURE RISE.
 MAXIMUM VOLTAGE: 2.4 KV
 MAXIMUM TEMPERATURE: 200°F (93°C)

- FEATURES:
 HOOK FITS COMPONENTS UP TO $\phi 0.045$ " [1.14].
 FIELD SERVICEABLE.

LTR		DESCRIPTION	REVISIONS	DATE	APPROVED
-----	--	-------------	-----------	------	----------

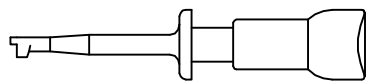
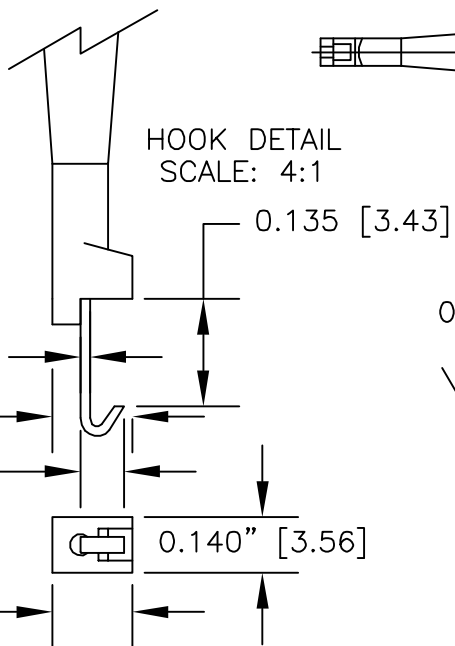
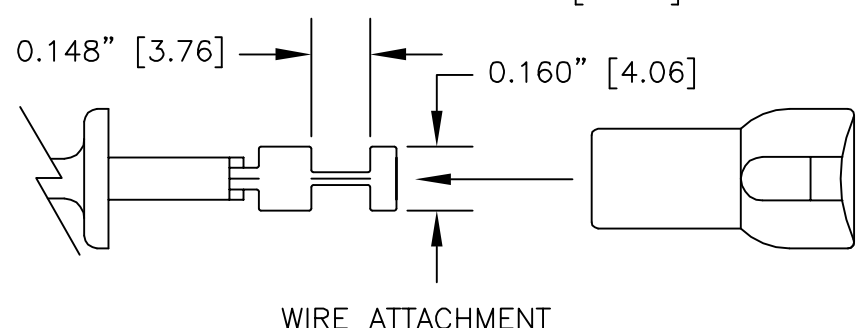
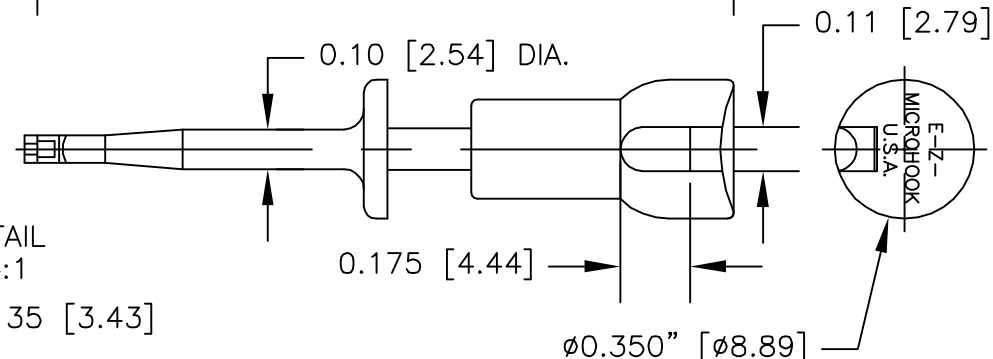
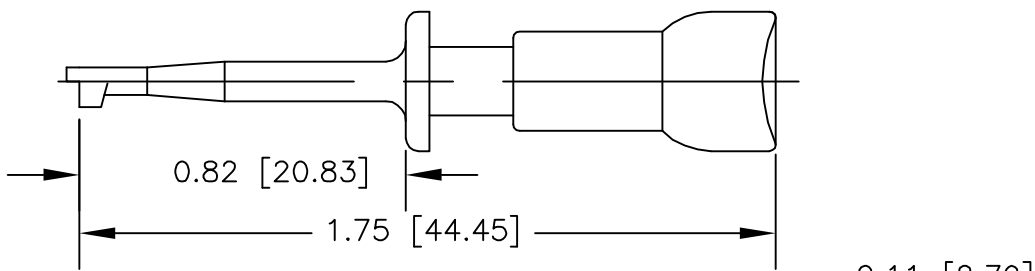

ACTUAL SIZE

		UNLESS OTHERWISE SPECIFIED DIMENSIONS ARE IN INCHES TOLERANCES ARE: FRACTIONS DECIMALS ANGLES ± .XX ± ± .XXX ±	CONTRACT NO.		E-Z-HOOK DIVISION OF TEKTEST INC. ARCADIA, CA 91006 U.S.A.	
			APPROVALS	DATE		
		MATERIAL SEE NOTE.	DRAWN	R.L.	6/09	DESCRIPTION E-Z-MICRO HOOK TEST CONNECTOR
			APPROVED BY			
		FINISH SEE NOTE.	SIZE	CODE IDENT NO.	DRAWING NO.	REV.
NEXT ASSY	USED ON		A	08505	XMCOLOR	
APPLICATION		DO NOT SCALE DRAWING	SCALE	2:1	SHEET 1 OF 1	

THE INFORMATION CONTAINED IN THIS DOCUMENT IS PROPRIETARY TO E-Z-HOOK. THE INFORMATION IS NOT TO BE REPRODUCED WITHOUT PRIOR WRITTEN PERMISSION OF E-Z-HOOK, DIV. OF TEKTEST INC. MAXIMUM TESTED RATINGS IN A HANDS-FREE CONTROLLED ENVIRONMENT. MAXIMUM RATINGS ARE NOT TO BE USED CONCURRENTLY.