

NOTES: UNLESS OTHERWISE SPECIFIED

1. CONSTRUCTION:

HOUSING & PLUNGER: MOLDED NYLON TYPE 6,6.  
 AVAILABLE IN RED & YEL.  
 CONTACT BLADE: BERYLLIUM COPPER PER QQ-C-533. GOLD PLATER PER MIL-G-45204 TYPE 1, 0.00001 [0.000254] THICK MINIMUM.  
 SPRING: STAINLESS STEEL TYPE 302.

2. PERFORMANCE:

MAXIMUM CURRENT: 4.4 AMPS WITH 76° TEMPERATURE RISE.  
 MAXIMUM VOLTAGE: 2.4 KV  
 MAXIMUM TEMPERATURE: 200°F (93°C)

3. FEATURES:

HOOK FITS COMPONENTS UP TO  $\phi 0.040$  [ $\phi 1.01$ ].  
 FIELD SERVICEABLE.

HOOK DETAIL SCALE: 4:1

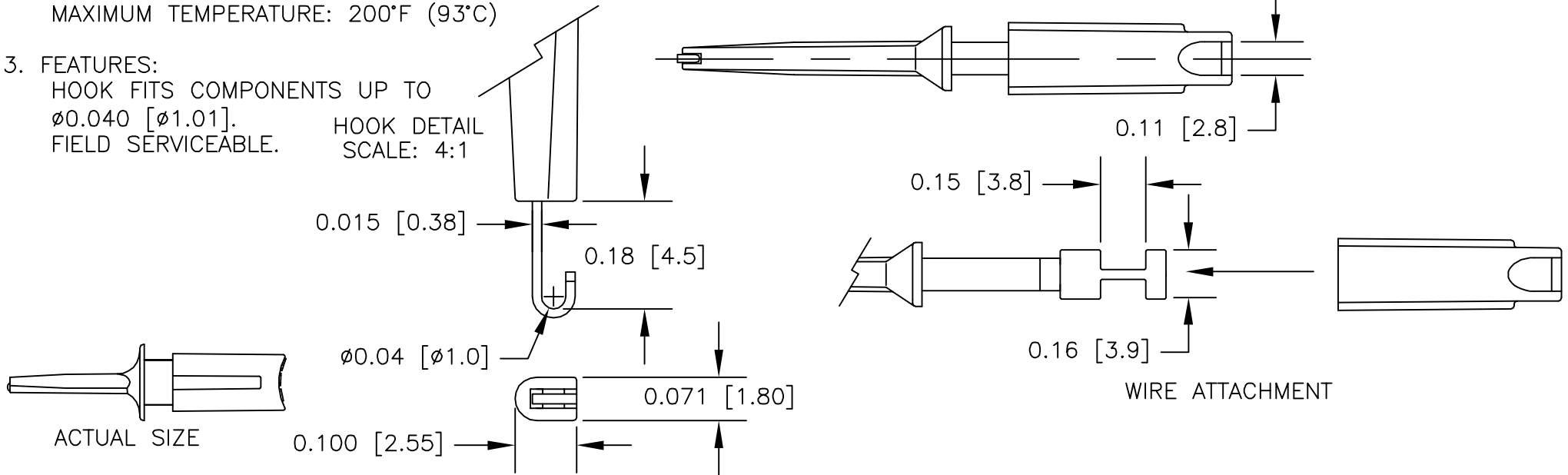

REVISIONS		DATE	APPROVED
LTR	DESCRIPTION		

		UNLESS OTHERWISE SPECIFIED DIMENSIONS ARE IN INCHES TOLERANCES ARE: FRACTIONS DECIMALS ANGLES ± .XX ± ± .XXX ±	CONTRACT NO.		<b>E-Z-HOOK</b> DIVISION OF TEKTEST INC. ARCADIA, CA 91006 U.S.A.  DESCRIPTION E-Z-MICRO HOOK TEST CONNECTOR  SIZE CODE IDENT NO. DRAWING NO. REV. <b>A 08505</b> XMRCOLOR  SCALE 2:1 SHEET 1 OF 1
			APPROVALS	DATE	
		DRAWN	R.L. 6/09		
		APPROVED BY			
		MATERIAL	SEE NOTE.		
		FINISH	SEE NOTE.		
NEXT ASSY	USED ON				
APPLICATION		DO NOT SCALE DRAWING			

THE INFORMATION CONTAINED IN THIS DOCUMENT IS PROPRIETARY TO E-Z-HOOK. THE INFORMATION IS NOT TO BE REPRODUCED WITHOUT PRIOR WRITTEN PERMISSION OF E-Z-HOOK, DIV. OF TEKTEST INC. MAXIMUM TESTED RATINGS IN A HANDS-FREE CONTROLLED ENVIRONMENT. MAXIMUM RATINGS ARE NOT TO BE USED CONCURRENTLY.