

## LPS200-M Series

250 Watts

**Total Power:** 125 - 250 Watts  
**Input Voltage:** 90 - 264 Vac  
**# of Outputs:** Single



### Special Features

- Medical and ITE safeties
- Active power factor correction
- 3" x 5" footprint
- Less than 1U high
- EN61000-3-2 compliant
- Remote sense
- Power fail
- Adjustable main output
- Built-in Class B EMI filter
- Overvoltage protection
- Overload protection
- Thermal overload protection
- Isolated 12V Fan output
- LPX200 enclosure kit available

### Safety

- **TUV** 60950, 60601-1
- **UL** 60950, 60601-1
- **cULus** 60950, 60601-1
- **CB** Certificate & report
- **CE** Mark (LVD)

### Electrical Specifications

Input	
Input range:	90 - 264 Vac; 120 - 300 Vdc
Frequency:	47-63 Hz
Inrush current:	50 A max., cold start @ 25 °C
Efficiency:	86% typical at full load
EMI/RFI:	FCC Class B conducted; CISPR22 Class B conducted; EN55022 Class B conducted; VDE0878PT3 Class B conducted
Power factor:	0.99 typical
Safety ground leakage current:	275 uA @ 50/60 Hz, 264 Vac input
Output	
Maximum power:	125 W for convection (100 W for LPS202-M) ; 250 W (200 W for LPS202-M) with 30CFM forced air
Adjustment range:	±10% minimum on the main outputs
Fan output:	12 V @ 0.5 A convection, @ 1 A forced air isolated, ±10%
Hold-up time:	16 ms @ 250 W load, 120 Vac input
Overload protection:	Short circuit protection on all outputs. Case overload protected @ 110-160% above rating
Overvoltage protection:	15-50% above nominal output
Logical Control	
Power failure:	Open collector logic signal goes high 100-500 msec after main output; it goes low at least 6 msec before loss of regulation
Remote sense:	Compensates for 0.5 V lead drop min. Will operate without remote sense connected. Reverse connection protected.

## Environmental Specifications

Operating temperature:	0° to 50 °C ambient derate each output as 2.5% per degree from 50° to 70 °C. -20 °C start up
Storage temperature:	-40 °C to +85 °C
Electromagnetic susceptibility:	Designed to meet EN61000-4; -2, -3, -4, -5, -6, -8, -11 Level 3
Humidity:	Operating; non-condensing 10% to 95% RH
Vibration:	IEC68-2-6 to the levels of IEC721-3-2
MTBF calculated:	1 million hours at full load and 25 °C ambient conditions. 230 Vac input, Bellcore

## Ordering Information

Model Number	Output Voltage	Minimum Load	Maximum Load with Convection Cooling	Maximum Load with 30CFM Forced Air	Peak Load	Regulation <sup>2</sup>	Ripple P/P (PARD) <sup>3</sup>
LPS202-M	5 V	0 A	20 A	40 A	44 A	±2%	50 mV
LPS203-M	12 V	0 A	10.3 A	20.8 A	22 A	±2%	120 mV
LPS204-M	15 V	0 A	8.3 A	16.6 A	18 A	±2%	150 mV
LPS205-M	24 V	0 A	5.2 A	10.4 A	11.5 A	±2%	240 mV
LPS208-M	48 V	0 A	2.6 A	5.2 A	5.8 A	±2%	480 mV

1. Peak current lasting <30 seconds with a maximum 10% duty cycle.
2. At 25°C including initial tolerance, line voltage, load currents and output voltages adjusted to factory settings.
3. Peak-to-peak with 20 MHz bandwidth and 10 µF (tantalum capacitor) in parallel with a 0.1 µF capacitor at rated line voltage and load ranges.

## Pin Assignments

Connector	LPS200-M	
SK1	Pin 1	Neutral
	Pin 3	Line
SK2	TB-1	Common
	TB-2	Main output
SK3	Pin 1	+V1 Remote sense
	Pin 2	-V1 Remote sense
	Pin 3	N/C
	Pin 4	N/C
	Pin 5	+Power fail
	Pin 6	Common
	Pin 7	N/C
	Pin 8	Common
	Pin 9	+12 V Fan
	Pin 10	+12 Fan Return (isolated)

## Mating Connectors

AC Input (SK1):	Molex 09-50-3031 (connector) PINS: 08-52-0072
AC Ground:	Molex 01-90020001
DC Output (SK2):	Molex 19141-0058/0063 or 19099-0044/0048 Spade lug based on Cable Ampacity/AWG
Control Signals (SK3):	Molex 90142-0010 (USA) PINS: 90119-2110 or Amp: 87977-3 PINS: 87309-8
Emerson Network Power Connector Kit #70-841-020, includes all of the above.	
1. Specifications subject to change without notice.	
2. All dimensions in inches (mm), tolerance is ±0.02" (±0.5mm)	
3. Mounting holes MH1 and MH2 should be grounded for EMI purposes.	
4. Mounting hole MH1 is safety ground connection.	
5. Specifications are for convection rating at factory settings at 115 VAC input, 25 °C unless otherwise stated.	
6. This power supply requires mounting on metal standoffs 0.20" (5m) in height.	
7. Warranty: 2 years	
8. Weight: 0.75 lb/0.34 kg	

Mechanical Drawing

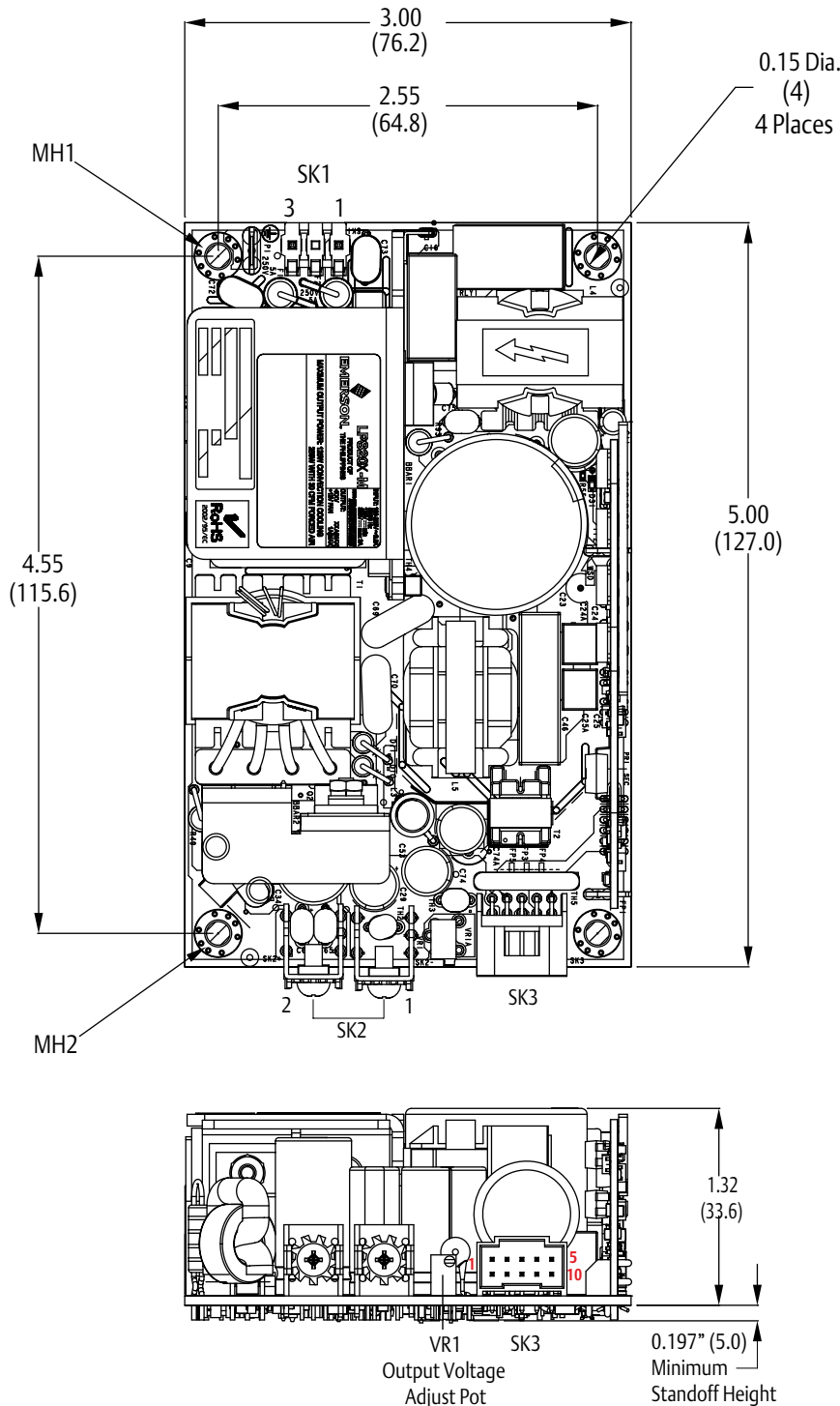

**Americas**

5810 Van Allen Way  
Carlsbad, CA 92008  
USA  
Telephone: +1 760 930 4600  
Facsimile: +1 760 930 0698

**Europe (UK)**

Waterfront Business Park  
Merry Hill, Dudley  
West Midlands, DY5 1LX  
United Kingdom  
Telephone: +44 (0) 1384 842 211  
Facsimile: +44 (0) 1384 843 355

**Asia (HK)**

14/F, Lu Plaza  
2 Wing Yip Street  
Kwun Tong, Kowloon  
Hong Kong  
Telephone: +852 2176 3333  
Facsimile: +852 2176 3888

For global contact, visit:

[www.Emerson.com/EmbeddedPower](http://www.Emerson.com/EmbeddedPower)  
[techsupport.embeddedpower@emerson.com](mailto:techsupport.embeddedpower@emerson.com)

While every precaution has been taken to ensure accuracy and completeness in this literature, Emerson Network Power assumes no responsibility, and disclaims all liability for damages resulting from use of this information or for any errors or omissions.

**Emerson Network Power.**  
The global leader in enabling  
business-critical continuity.

- AC Power
- Connectivity
- DC Power
- Embedded Computing
- **Embedded Power**
- Monitoring
- Outside Plant
- Power Switching & Controls
- Precision Cooling
- Racks & Integrated Cabinets
- Services
- Surge Protection

**EmersonNetworkPower.com**

Emerson Network Power and the Emerson Network Power logo are trademarks and service marks of Emerson Electric Co.  
©2010 Emerson Electric Co.