

SURFACE MOUNT GLASS PASSIVATED BRIDGE RECTIFIERS

REVERSE VOLTAGE - 50 to 1000 Volts
FORWARD CURRENT - 0.8 Ampere

FEATURES

- Rating to 1000V PRV
- Ideal for printed circuit board
- Reliable low cost construction utilizing molded plastic technique results in inexpensive product
- Lead tin plated copper

MECHANICAL DATA

- Polarity: Symbol molded on body
- Mounting position : Any

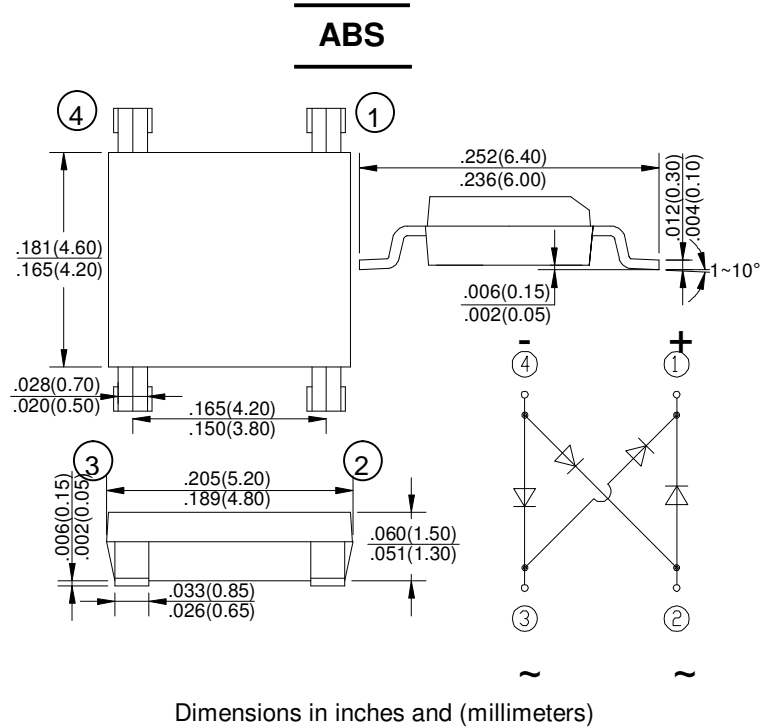

MAXIMUM RATINGS AND ELECTRICAL CHARACTERISTICS

Rating at 25°C ambient temperature unless otherwise specified.

Single phase, half wave ,60Hz, resistive or inductive load.

For capacitive load, derate current by 20%

CHARACTERISTICS	SYMBOL	ABS05	ABS1	ABS2	ABS4	ABS6	ABS8	ABS10	UNIT
Maximum Recurrent Peak Reverse Voltage	V _{RRM}	50	100	200	400	600	800	1000	V
Maximum RMS Voltage	V _{RMS}	35	70	140	280	420	560	700	V
Maximum DC Blocking Voltage	V _{DC}	50	100	200	400	600	800	1000	V
Maximum Average Forward Rectified Current (Note 1) @T _A =40 °C	I _(AV)	0.8							A
Peak Forward Surge Current 8.3ms Single Half Sine-Wave Super Imposed on Rated Load(JEDEC Method)	I _{FSM}	30							A
Peak Forward Voltage at 0.8A DC	V _F	1.1							V
Maximum DC Reverse Current at Rated DC Blocking Voltage @T _J =25°C @T _J =125°C	I _R	5.0 500							μA
Typical Thermal Resistance (Note2)	R _{θJA}	80							°C/W
Operating Temperature Range	T _J	-55 to +150							°C
Storage Temperature Range	T _{STG}	-55 to +150							°C

NOTES:1.Mounted on P.C. board.

2.Thermal resistance junction to ambient.

FIG.1-FORWARD CURRENT DERATING CURVE

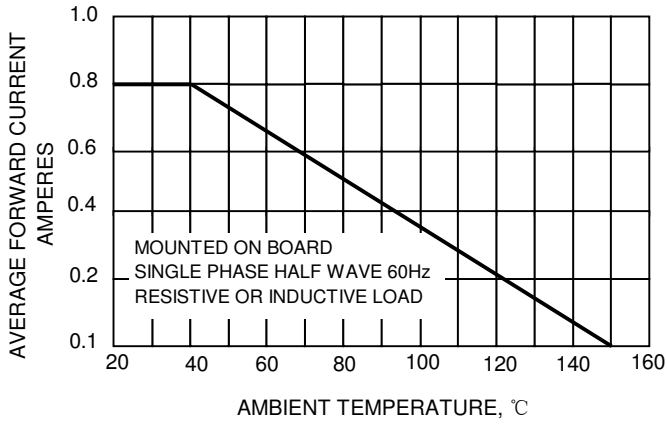

FIG.2 - MAXIMUM NON-REPETITIVE SURGE CURRENT

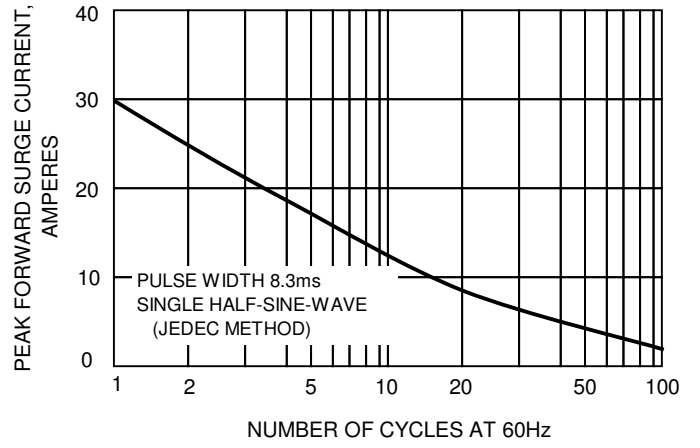

FIG.3-TYPICAL REVERSE CHARACTERISTICS

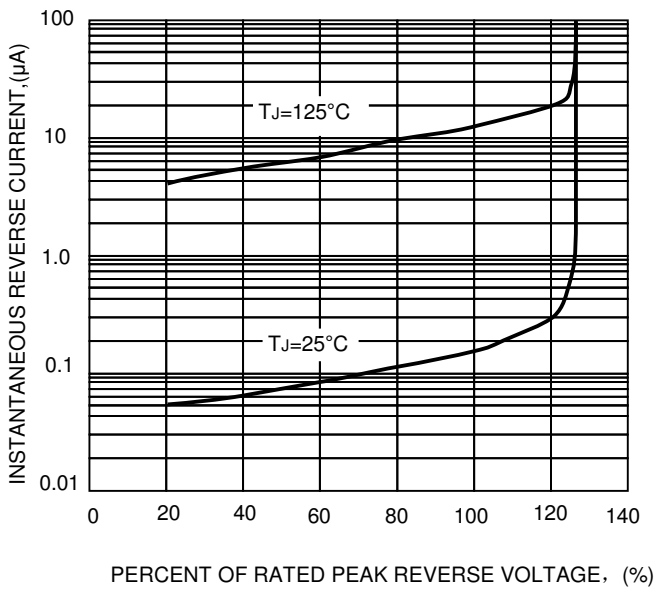

FIG.4-TYPICAL FORWARD CHARACTERISTICS

