

SILICON BRIDGE RECTIFIERS

REVERSE VOLTAGE - 50 to 1000Volts
 FORWARD CURRENT - 3.0 Amperes

FEATURES

- Surge overload rating - 40 amperes peak
- Low forward voltage drop
- Small size; simple installation
- Tinned copper leads
- Mounting position: Any
- Mounting: Thru hole for #6 screw

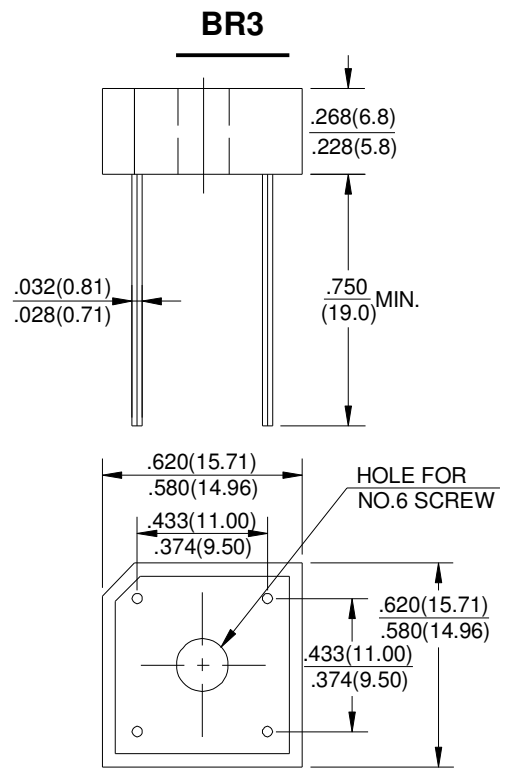

Dimensions in inches and (millimeters)

MAXIMUM RATINGS AND ELECTRICAL CHARACTERISTICS

Rating at 25°C ambient temperature unless otherwise specified.

Single phase, half wave ,60Hz, resistive or inductive load.

For capacitive load, derate current by 20%

CHARACTERISTICS	SYMBOL	BR3005	BR301	BR302	BR304	BR306	BR308	BR310	UNIT
Maximum Recurrent Peak Reverse Voltage	V _{RRM}	50	100	200	400	600	800	1000	v
Maximum RMS Bridge Input Voltage	V _{RMS}	35	70	140	280	420	560	700	v
Maximum Average Forward Rectified Output Current at T _A =50°C	I _(AV)	3.0							A
Peak Forward Surge Current 8.3ms Single Half Sine-Wave Super Imposed on Rated Load	I _{FSM}	40							A
Maximum Forward Voltage Drop Per Bridge Element at 1.5A Peak	V _F	1.1							V
Maximum Reverse Current at Rated T _J =25°C	I _R	10.0							μA
DC Blocking Voltage Per Element T _J =100°C		1.0							mA
Operating Temperature Range	T _J	-55 to +150							°C
Storage Temperature Range	T _{STG}	-55 to +150							°C

FIG.1-MXIMUM NON-REPETITIVE SURGE CURRENT

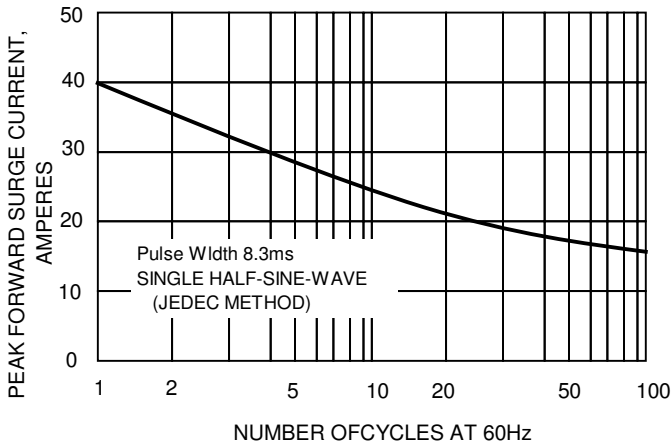

FLG.2-DE RATING CURVE
 OUTPUT RECTIFIED CURRENT

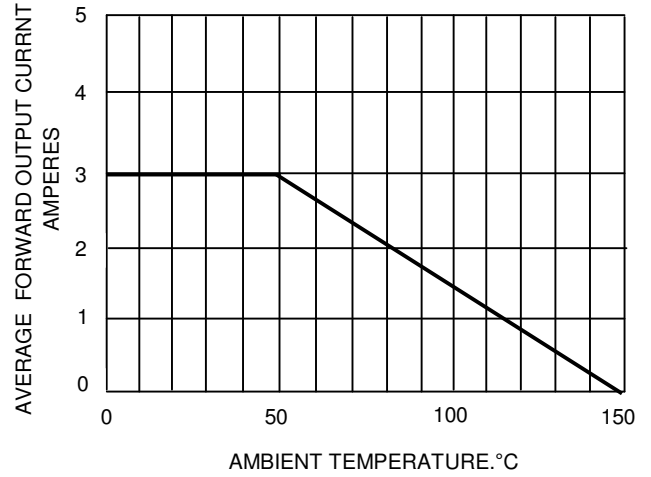

FLG.3-TYPICAL FORWARD CHARACTERISTICS

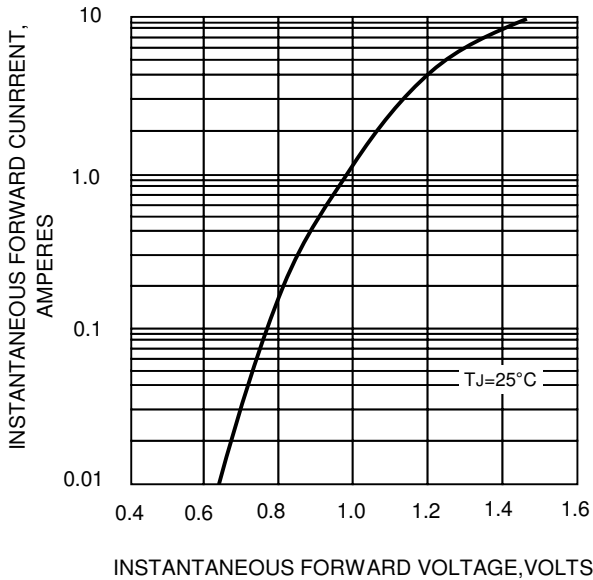

FIG.4-TYPICAL REVERSE CHARACTERISTICS

