

GLASS PASSIVATED BRIDGE RECTIFIERS

REVERSE VOLTAGE - **50** to **1000** Volts
FORWARD CURRENT - **2.0** Amperes

FEATURES

- Surge overload rating -60 amperes peak
- Ideal for printed circuit board
- Reliable low cost construction utilizing molded plastic technique results in expensive product
- Mounting Position :Any
- Lead:sliver plated copper lead.

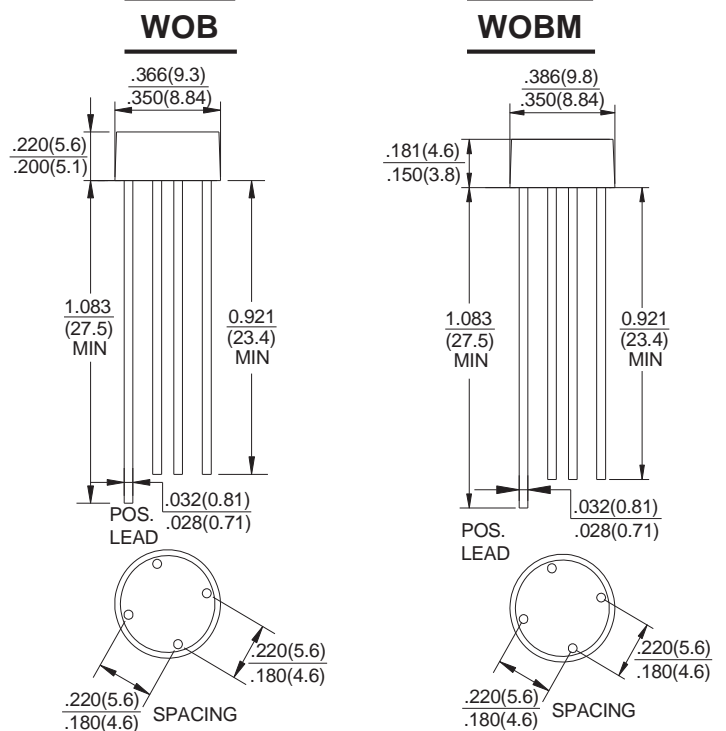

Dimensions in inches and (millimeters)

MAXIMUM RATINGS AND ELECTRICAL CHARACTERISTICS

Rating at 25°C ambient temperature unless otherwise specified.

Single phase, half wave ,60Hz, resistive or inductive load.

For capacitive load, derate current by 20%

CHARACTERISTICS	SYMBOL	2W005G	2W01G	2W02G	2W04G	2W06G	2W08G	2W10G	UNIT
		2W005MG	2W01MG	2W02MG	2W04MG	2W06MG	2W08MG	2W10MG	
Maximum Recurrent Peak Reverse Voltage	V _{RRM}	50	100	200	400	600	800	1000	V
Maximum RMS Bridge Input Voltage	V _{RMS}	35	70	140	280	420	560	700	V
Maximum DC Blocking Voltage	V _{DC}	50	100	200	400	600	800	1000	V
Maximum Average Forward Rectified Current @T _A =25°C	I <sub(av)< sub=""></sub(av)<>	2.0							A
Peak Forward Surge Current , 8.3ms Single Half Sine-Wave Super Imposed on Rated Load	I _{FSM}	60							A
I ² t Rating for Fusing (t<8.3ms)	I ² t	15.0							A ² s
Maximum Forward Voltage Drop per Element at 2.0A Peak	V _F	1.1							V
Maximum Reverse Current at Rated DC Blocking Voltage T _J =25°C	I _R	10.0							µA
Maximum Reverse Current at Rated DC Blocking Voltage T _J =100°C	I _R	1.0							mA
Typical Junction Capacitance Per Element (Note1)	C _J	30							pF
Operating Temperature Range	T _J	-55 to +150							°C
Operating Temperature Range	T _{STG}	-55 to +150							°C

Note:1.Measured at 1.0MHz and applied reverse voltage of 4.0V DC.

FIG.1-FORATING CURVE
 OUTPUT RECTIFIED
 CURRENT

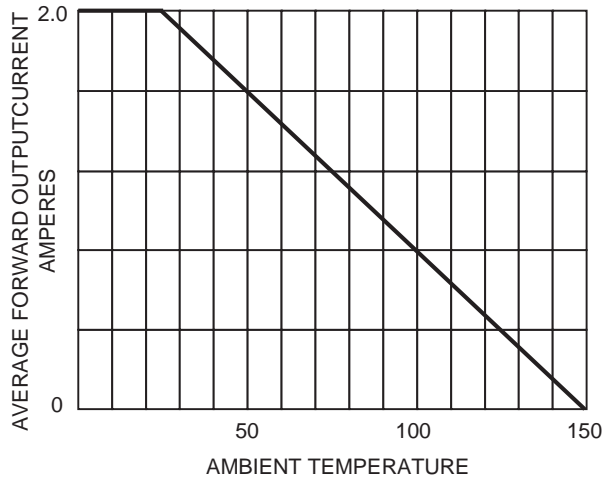

FIG.2-MAXIMUM NON-REPETITIVE PEAK
 FORWARD SURGE CURRENT

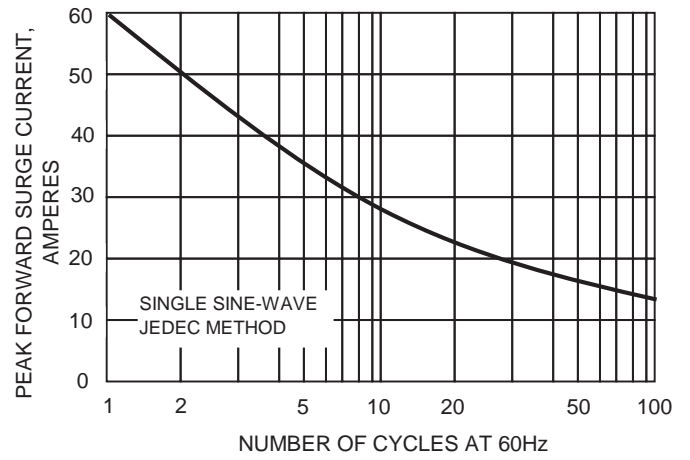

FIG.3-TYPIACL REVERSE CHARACTERISTICS

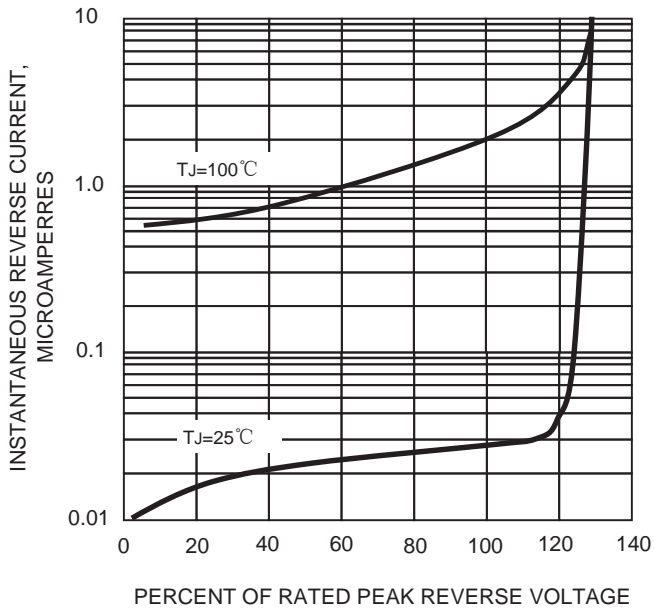

FIG.3-TYPICAL FORWARD CHARACTERISTICS

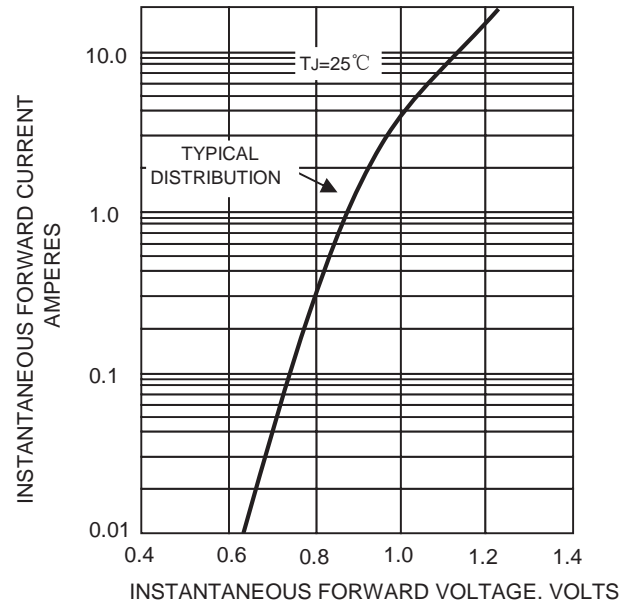

FIG.5-TYPICAL JUNCTION CAPACITANCE PER BRIDGE

