

74AVC16T245

16-bit dual supply translating transceiver with configurable voltage translation; 3-state

Rev. 5 — 9 March 2012

Product data sheet

1. General description

The 74AVC16T245 is a 16-bit transceiver with bidirectional level voltage translation and 3-state outputs. The device can be used as two 8-bit transceivers or as a 16-bit transceiver. It has dual supplies ($V_{CC(A)}$ and $V_{CC(B)}$) for voltage translation and four 8-bit input-output ports (nAn and nBn) each with its own output enable (\overline{nOE}) and send/receive ($nDIR$) input for direction control. $V_{CC(A)}$ and $V_{CC(B)}$ can be independently supplied at any voltage between 0.8 V and 3.6 V making the device suitable for low voltage translation between any of the following voltages: 0.8 V, 1.2 V, 1.5 V, 1.8 V, 2.5 V and 3.3 V. A HIGH on $nDIR$ selects transmission from nAn to nBn while a LOW on $nDIR$ selects transmission from nBn to nAn . A HIGH on \overline{nOE} causes the outputs to assume a high-impedance OFF-state

The device is fully specified for partial power-down applications using I_{OFF} . The I_{OFF} circuitry disables the output, preventing any damaging backflow current through the device when it is powered down. In suspend mode when either $V_{CC(A)}$ or $V_{CC(B)}$ are at GND level, both nAn and nBn are in the high-impedance OFF-state.

2. Features and benefits

- Wide supply voltage range:
 - ◆ $V_{CC(A)}$: 0.8 V to 3.6 V
 - ◆ $V_{CC(B)}$: 0.8 V to 3.6 V
- Complies with JEDEC standards:
 - ◆ JESD8-12 (0.8 V to 1.3 V)
 - ◆ JESD8-11 (0.9 V to 1.65 V)
 - ◆ JESD8-7 (1.2 V to 1.95 V)
 - ◆ JESD8-5 (1.8 V to 2.7 V)
 - ◆ JESD8-B (2.7 V to 3.6 V)
- ESD protection:
 - ◆ HBM JESD22-A114F Class 3B exceeds 8000 V
 - ◆ MM JESD22-A115-A exceeds 200 V
 - ◆ CDM JESD22-C101D exceeds 1000 V
- Maximum data rates:
 - ◆ 380 Mbit/s (\geq 1.8 V to 3.3 V translation)
 - ◆ 200 Mbit/s (\geq 1.1 V to 3.3 V translation)
 - ◆ 200 Mbit/s (\geq 1.1 V to 2.5 V translation)
 - ◆ 200 Mbit/s (\geq 1.1 V to 1.8 V translation)
 - ◆ 150 Mbit/s (\geq 1.1 V to 1.5 V translation)



- ◆ 100 Mbit/s (≥ 1.1 V to 1.2 V translation)
- Suspend mode
- Latch-up performance exceeds 100 mA per JESD 78 Class II
- Inputs accept voltages up to 3.6 V
- I_{OFF} circuitry provides partial Power-down mode operation
- Multiple package options
- Specified from -40 °C to $+85$ °C and -40 °C to $+125$ °C

3. Ordering information

Table 1. Ordering information

Type number	Package			Version
	Temperature range	Name	Description	
74AVC16T245DGG	-40 °C to $+125$ °C	TSSOP48	plastic thin shrink small outline package; 48 leads; body width 6.1 mm	SOT362-1
74AVC16T245DGV	-40 °C to $+125$ °C	TSSOP48 ^[1]	plastic thin shrink small outline package; 48 leads; body width 4.4 mm; lead pitch 0.4 mm	SOT480-1
74AVC16T245EV	-40 °C to $+125$ °C	VFBGA56	plastic very thin fine-pitch ball grid array package; 56 balls; body $4.5 \times 7 \times 0.65$ mm	SOT702-1
74AVC16T245BX	-40 °C to $+125$ °C	HXQFN60	plastic compatible thermal enhanced extremely thin quad flat package; no leads; 60 terminals; body $4 \times 6 \times 0.5$ mm	SOT1134-2

[1] Also known as TVSOP48.

4. Functional diagram

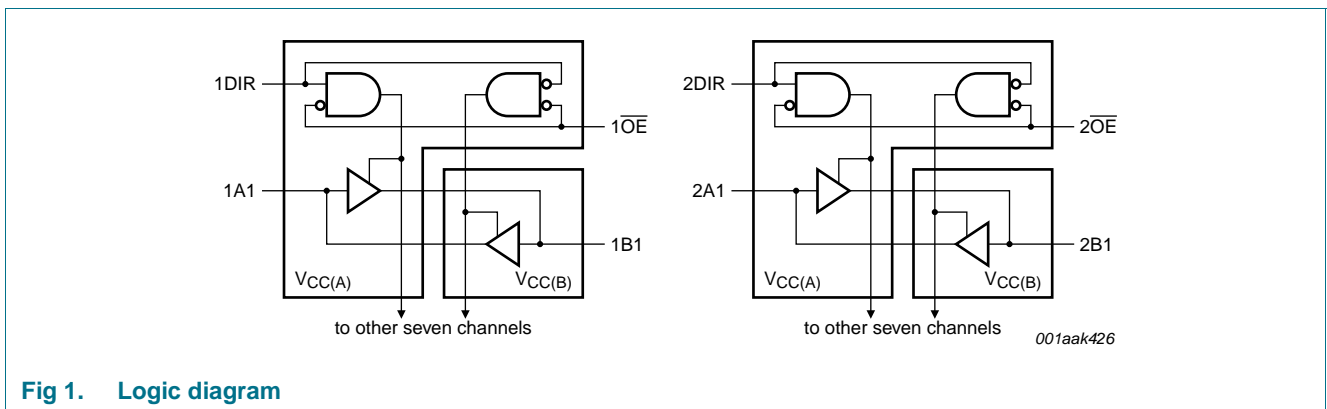

Fig 1. Logic diagram

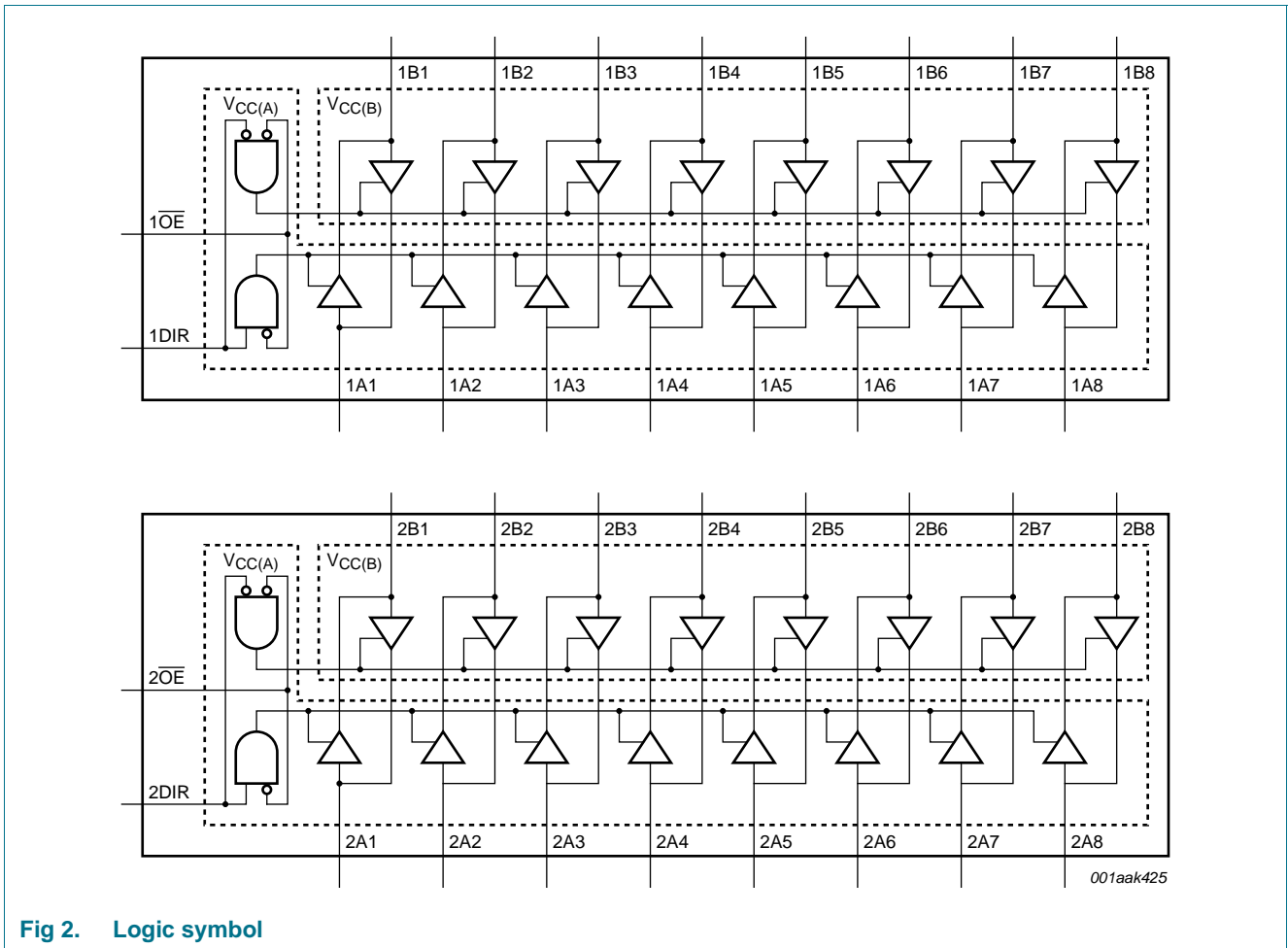

Fig 2. Logic symbol

5. Pinning information

5.1 Pinning

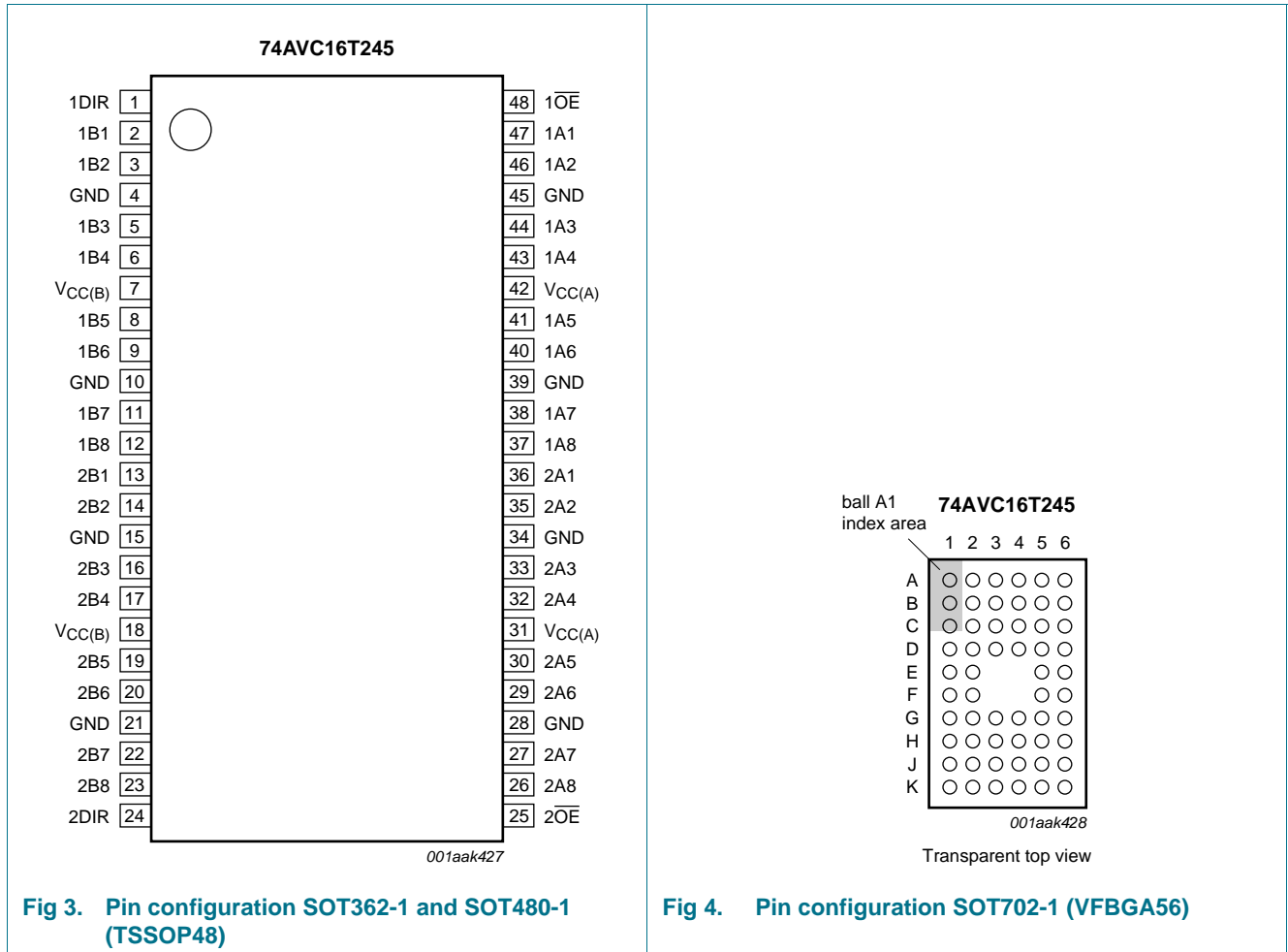
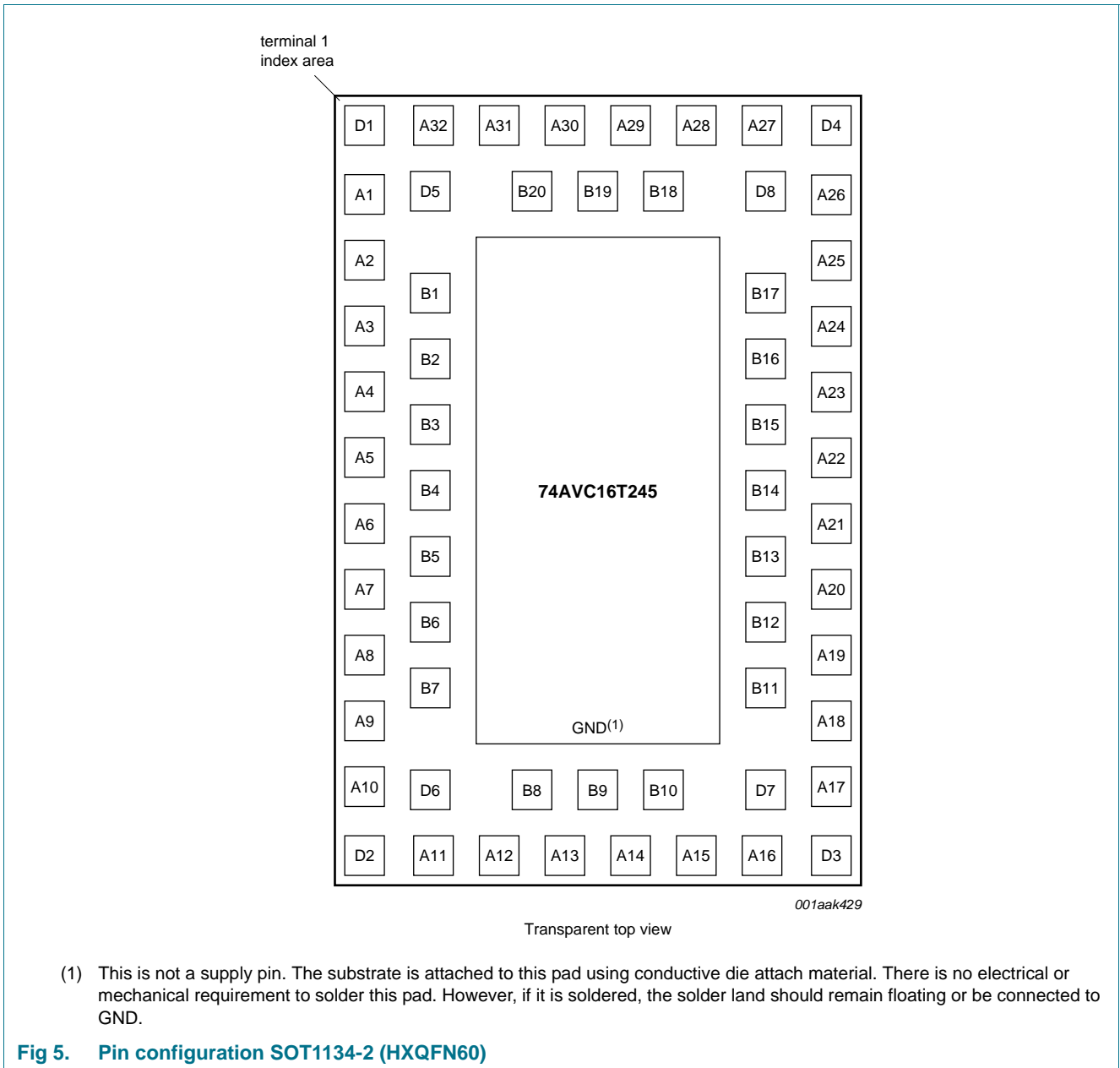

Fig 3. Pin configuration SOT362-1 and SOT480-1 (TSSOP48)

Fig 4. Pin configuration SOT702-1 (VFBGA56)



5.2 Pin description

Table 2. Pin description

Symbol	Pin			Description
	SOT362-1 and SOT480-1	SOT702-1	SOT1134-2	
1DIR, 2DIR	1, 24	A1, K1	A30, A13	direction control
1B1 to 1B8	2, 3, 5, 6, 8, 9, 11, 12	B2, B1, C2, C1, D2, D1, E2, E1	B20, A31, D5, D1, A2, B2, B3, A5	data input or output
2B1 to 2B8	13, 14, 16, 17, 19, 20, 22, 23	F1, F2, G1, G2, H1, H2, J1, J2	A6, B5, B6, A9, D2, D6, A12, B8	data input or output
GND ^[1]	4, 10, 15, 21, 28, 34, 39, 45	B3, D3, G3, J3, J4, G4, D4, B4	A32, A3, A8, A11, A16, A19, A24, A27	ground (0 V)
V _{CC(B)}	7, 18	C3, H3	A1, A10	supply voltage B (nBn inputs are referenced to V _{CC(B)})
$\overline{1OE}$, $\overline{2OE}$	48, 25	A6, K6	A29, A14	output enable input (active LOW)
1A1 to 1A8	47, 46, 44, 43, 41, 40, 38, 37	B5, B6, C5, C6, D5, D6, E5, E6	B18, A28, D8, D4, A25, B16, B15, A22	data input or output
2A1 to 2A8	36, 35, 33, 32, 30, 29, 27, 26	F6, F5, G6, G5, H6, H5, J6, J5	A21, B13, B12, A18, D3, D7, A15, B10	data input or output
V _{CC(A)}	31, 42	C4, H4	A17, A26	supply voltage A (nAn, \overline{nOE} and nDIR inputs are referenced to V _{CC(A)})
n.c.	-	A2, A3, A4, A5, K2, K3, K4, K5	A4, A7, A20, A23, B1, B4, B7, B9, B11, B14, B17, B19	not connected

[1] All GND pins must be connected to ground (0 V).

6. Functional description

Table 3. Function table^[1]

Supply voltage	Input		Input/output ^[3]	
	\overline{nOE} ^[2]	nDIR ^[2]	nAn ^[2]	nBn ^[2]
0.8 V to 3.6 V	L	L	nAn = nBn	input
0.8 V to 3.6 V	L	H	input	nBn = nAn
0.8 V to 3.6 V	H	X	Z	Z
GND ^[3]	X	X	Z	Z

[1] H = HIGH voltage level; L = LOW voltage level; X = don't care; Z = high-impedance OFF-state.

[2] The nAn, nDIR and \overline{nOE} input circuit is referenced to V_{CC(A)}; The nBn input circuit is referenced to V_{CC(B)}.

[3] If at least one of V_{CC(A)} or V_{CC(B)} is at GND level, the device goes into suspend mode.

7. Limiting values

Table 4. Limiting values

In accordance with the Absolute Maximum Rating System (IEC 60134). Voltages are referenced to GND (ground = 0 V).

Symbol	Parameter	Conditions	Min	Max	Unit
$V_{CC(A)}$	supply voltage A		-0.5	+4.6	V
$V_{CC(B)}$	supply voltage B		-0.5	+4.6	V
I_{IK}	input clamping current	$V_I < 0$ V	-50	-	mA
V_I	input voltage		[1] -0.5	+4.6	V
I_{OK}	output clamping current	$V_O < 0$ V	-50	-	mA
V_O	output voltage	Active mode	[1][2][3] -0.5	$V_{CCO} + 0.5$	V
		Suspend or 3-state mode	[1] -0.5	+4.6	V
I_O	output current	$V_O = 0$ V to V_{CCO}	[2] -	± 50	mA
I_{CC}	supply current	$I_{CC(A)}$ or $I_{CC(B)}$	-	100	mA
I_{GND}	ground current		-100	-	mA
T_{stg}	storage temperature		-65	+150	°C
P_{tot}	total power dissipation	$T_{amb} = -40$ °C to +125 °C;			
		TSSOP48 package	[4] -	500	mW
		VFBGA56 package	[5] -	1000	mW
		HXQFN60 package	[5] -	1000	mW

- [1] The minimum input voltage ratings and output voltage ratings may be exceeded if the input and output current ratings are observed.
- [2] V_{CCO} is the supply voltage associated with the output port.
- [3] $V_{CCO} + 0.5$ V should not exceed 4.6 V.
- [4] Above 60 °C the value of P_{tot} derates linearly with 5.5 mW/K.
- [5] Above 70 °C the value of P_{tot} derates linearly with 1.8 mW/K.

8. Recommended operating conditions

Table 5. Recommended operating conditions

Symbol	Parameter	Conditions	Min	Max	Unit
$V_{CC(A)}$	supply voltage A		0.8	3.6	V
$V_{CC(B)}$	supply voltage B		0.8	3.6	V
V_I	input voltage		0	3.6	V
V_O	output voltage	Active mode	[1] 0	V_{CCO}	V
		Suspend or 3-state mode	0	3.6	V
T_{amb}	ambient temperature		-40	+125	°C
$\Delta t/\Delta V$	input transition rise and fall rate	$V_{CCI} = 0.8$ V to 3.6 V	[2] -	5	ns/V

- [1] V_{CCO} is the supply voltage associated with the output port.
- [2] V_{CCI} is the supply voltage associated with the input port.

9. Static characteristics

Table 6. Typical static characteristics at $T_{amb} = 25\text{ °C}$ [1][2]

At recommended operating conditions; voltages are referenced to GND (ground = 0 V).

Symbol	Parameter	Conditions	Min	Typ	Max	Unit	
V_{OH}	HIGH-level output voltage	$V_I = V_{IH}$ or V_{IL} $I_O = -1.5\text{ mA}$; $V_{CC(A)} = V_{CC(B)} = 0.8\text{ V}$	-	0.69	-	V	
V_{OL}	LOW-level output voltage	$V_I = V_{IH}$ or V_{IL} $I_O = 1.5\text{ mA}$; $V_{CC(A)} = V_{CC(B)} = 0.8\text{ V}$	-	0.07	-	V	
I_I	input leakage current	nDIR, \overline{nOE} input; $V_I = 0\text{ V}$ or 3.6 V ; $V_{CC(A)} = V_{CC(B)} = 0.8\text{ V}$ to 3.6 V	-	± 0.025	± 0.25	μA	
I_{OZ}	OFF-state output current	A or B port; $V_O = 0\text{ V}$ or V_{CCO} ; $V_{CC(A)} = V_{CC(B)} = 3.6\text{ V}$	[3]	-	± 0.5	± 2.5	μA
		suspend mode A port; $V_O = 0\text{ V}$ or V_{CCO} ; $V_{CC(A)} = 3.6\text{ V}$; $V_{CC(B)} = 0\text{ V}$	[3]	-	± 0.5	± 2.5	μA
		suspend mode B port; $V_O = 0\text{ V}$ or V_{CCO} ; $V_{CC(A)} = 0\text{ V}$; $V_{CC(B)} = 3.6\text{ V}$	[3]	-	± 0.5	± 2.5	μA
I_{OFF}	power-off leakage current	A port; V_I or $V_O = 0\text{ V}$ to 3.6 V ; $V_{CC(A)} = 0\text{ V}$; $V_{CC(B)} = 0.8\text{ V}$ to 3.6 V	-	± 0.1	± 1	μA	
		B port; V_I or $V_O = 0\text{ V}$ to 3.6 V ; $V_{CC(B)} = 0\text{ V}$; $V_{CC(A)} = 0.8\text{ V}$ to 3.6 V	-	± 0.1	± 1	μA	
C_I	input capacitance	nDIR, \overline{nOE} input; $V_I = 0\text{ V}$ or 3.3 V ; $V_{CC(A)} = V_{CC(B)} = 3.3\text{ V}$	-	2.0	-	pF	
$C_{I/O}$	input/output capacitance	A and B port; $V_O = 3.3\text{ V}$ or 0 V ; $V_{CC(A)} = V_{CC(B)} = 3.3\text{ V}$	-	4.5	-	pF	

- [1] V_{CCO} is the supply voltage associated with the output port.
- [2] V_{CCI} is the supply voltage associated with the data input port.
- [3] For I/O ports, the parameter I_{OZ} includes the input leakage current.

Table 7. Static characteristics [1][2]

At recommended operating conditions; voltages are referenced to GND (ground = 0 V).

Symbol	Parameter	Conditions	-40 °C to +85 °C		-40 °C to +125 °C		Unit
			Min	Max	Min	Max	
V_{IH}	HIGH-level input voltage	data input					
		$V_{CCI} = 0.8\text{ V}$	$0.70V_{CCI}$	-	$0.70V_{CCI}$	-	V
		$V_{CCI} = 1.1\text{ V}$ to 1.95 V	$0.65V_{CCI}$	-	$0.65V_{CCI}$	-	V
		$V_{CCI} = 2.3\text{ V}$ to 2.7 V	1.6	-	1.6	-	V
		$V_{CCI} = 3.0\text{ V}$ to 3.6 V	2	-	2	-	V
		nDIR, \overline{nOE} input					
		$V_{CC(A)} = 0.8\text{ V}$	$0.70V_{CC(A)}$	-	$0.70V_{CC(A)}$	-	V
		$V_{CC(A)} = 1.1\text{ V}$ to 1.95 V	$0.65V_{CC(A)}$	-	$0.65V_{CC(A)}$	-	V
		$V_{CC(A)} = 2.3\text{ V}$ to 2.7 V	1.6	-	1.6	-	V
		$V_{CC(A)} = 3.0\text{ V}$ to 3.6 V	2	-	2	-	V

Table 7. Static characteristics ...continued [1][2]

At recommended operating conditions; voltages are referenced to GND (ground = 0 V).

Symbol	Parameter	Conditions	-40 °C to +85 °C		-40 °C to +125 °C		Unit	
			Min	Max	Min	Max		
V _{IL}	LOW-level input voltage	data input						
		V _{CCI} = 0.8 V	-	0.30V _{CCI}	-	0.30V _{CCI}	V	
		V _{CCI} = 1.1 V to 1.95 V	-	0.35V _{CCI}	-	0.35V _{CCI}	V	
		V _{CCI} = 2.3 V to 2.7 V	-	0.7	-	0.7	V	
		V _{CCI} = 3.0 V to 3.6 V	-	0.8	-	0.8	V	
		nDIR, n $\overline{\text{OE}}$ input						
		V _{CC(A)} = 0.8 V	-	0.30V _{CC(A)}	-	0.30V _{CC(A)}	V	
		V _{CC(A)} = 1.1 V to 1.95 V	-	0.35V _{CC(A)}	-	0.35V _{CC(A)}	V	
V _{OH}	HIGH-level output voltage	V _I = V _{IH} or V _{IL}						
		I _O = -100 μ A; V _{CC(A)} = V _{CC(B)} = 0.8 V to 3.6 V	V _{CCO} - 0.1	-	V _{CCO} - 0.1	-	V	
		I _O = -3 mA; V _{CC(A)} = V _{CC(B)} = 1.1 V	0.85	-	0.85	-	V	
		I _O = -6 mA; V _{CC(A)} = V _{CC(B)} = 1.4 V	1.05	-	1.05	-	V	
		I _O = -8 mA; V _{CC(A)} = V _{CC(B)} = 1.65 V	1.2	-	1.2	-	V	
		I _O = -9 mA; V _{CC(A)} = V _{CC(B)} = 2.3 V	1.75	-	1.75	-	V	
		I _O = -12 mA; V _{CC(A)} = V _{CC(B)} = 3.0 V	2.3	-	2.3	-	V	
V _{OL}	LOW-level output voltage	V _I = V _{IH} or V _{IL}						
		I _O = 100 μ A; V _{CC(A)} = V _{CC(B)} = 0.8 V to 3.6 V	-	0.1	-	0.1	V	
		I _O = 3 mA; V _{CC(A)} = V _{CC(B)} = 1.1 V	-	0.25	-	0.25	V	
		I _O = 6 mA; V _{CC(A)} = V _{CC(B)} = 1.4 V	-	0.35	-	0.35	V	
		I _O = 8 mA; V _{CC(A)} = V _{CC(B)} = 1.65 V	-	0.45	-	0.45	V	
		I _O = 9 mA; V _{CC(A)} = V _{CC(B)} = 2.3 V	-	0.55	-	0.55	V	
		I _O = 12 mA; V _{CC(A)} = V _{CC(B)} = 3.0 V	-	0.7	-	0.7	V	
I _I	input leakage current	nDIR, n $\overline{\text{OE}}$ input; V _I = 0 V or 3.6 V; V _{CC(A)} = V _{CC(B)} = 0.8 V to 3.6 V	-	± 1	-	± 5	μ A	
I _{OZ}	OFF-state output current	A or B port; V _O = 0 V or V _{CCO} ; V _{CC(A)} = V _{CC(B)} = 3.6 V	[3]	-	± 5	-	± 30	μ A
		suspend mode A port; V _O = 0 V or V _{CCO} ; V _{CC(A)} = 3.6 V; V _{CC(B)} = 0 V	[3]	-	± 5	-	± 30	μ A
		suspend mode B port; V _O = 0 V or V _{CCO} ; V _{CC(A)} = 0 V; V _{CC(B)} = 3.6 V	[3]	-	± 5	-	± 30	μ A

Table 7. Static characteristics ...continued [1][2]

At recommended operating conditions; voltages are referenced to GND (ground = 0 V).

Symbol	Parameter	Conditions	-40 °C to +85 °C		-40 °C to +125 °C		Unit
			Min	Max	Min	Max	
I _{OFF}	power-off leakage current	A port; V _I or V _O = 0 V to 3.6 V; V _{CC(A)} = 0 V; V _{CC(B)} = 0.8 V to 3.6 V	-	±5	-	±30	μA
		B port; V _I or V _O = 0 V to 3.6 V; V _{CC(B)} = 0 V; V _{CC(A)} = 0.8 V to 3.6 V	-	±5	-	±30	μA
I _{CC}	supply current	A port; V _I = 0 V or V _{CCI} ; I _O = 0 A					
		V _{CC(A)} = 0.8 V to 3.6 V; V _{CC(B)} = 0.8 V to 3.6 V	-	30	-	125	μA
		V _{CC(A)} = 1.1 V to 3.6 V; V _{CC(B)} = 1.1 V to 3.6 V	-	25	-	100	μA
		V _{CC(A)} = 3.6 V; V _{CC(B)} = 0 V	-	25	-	100	μA
		V _{CC(A)} = 0 V; V _{CC(B)} = 3.6 V	-5	-	-20	-	μA
		B port; V _I = 0 V or V _{CCI} ; I _O = 0 A					
		V _{CC(A)} = 0.8 V to 3.6 V; V _{CC(B)} = 0.8 V to 3.6 V	-	30	-	125	μA
		V _{CC(A)} = 1.1 V to 3.6 V; V _{CC(B)} = 1.1 V to 3.6 V	-	25	-	100	μA
		V _{CC(A)} = 3.6 V; V _{CC(B)} = 0 V	-5	-	-20	-	μA
		V _{CC(A)} = 0 V; V _{CC(B)} = 3.6 V	-	25	-	100	μA
A plus B port (I _{CC(A)} + I _{CC(B)}); I _O = 0 A; V _I = 0 V or V _{CCI} ; V _{CC(A)} = 0.8 V to 3.6 V; V _{CC(B)} = 0.8 V to 3.6 V	-	55	-	185	μA		
A plus B port (I _{CC(A)} + I _{CC(B)}); I _O = 0 A; V _I = 0 V or V _{CCI} ; V _{CC(A)} = 1.1 V to 3.6 V; V _{CC(B)} = 1.1 V to 3.6 V	-	45	-	150	μA		

- [1] V_{CCO} is the supply voltage associated with the output port.
- [2] V_{CCI} is the supply voltage associated with the data input port.
- [3] For I/O ports, the parameter I_{OZ} includes the input leakage current.

Table 8. Typical total supply current (I_{CC(A)} + I_{CC(B)})

V _{CC(A)}	V _{CC(B)}							Unit
	0 V	0.8 V	1.2 V	1.5 V	1.8 V	2.5 V	3.3 V	
0 V	0	0.1	0.1	0.1	0.1	0.1	0.1	μA
0.8 V	0.1	0.1	0.1	0.1	0.1	0.3	1.6	μA
1.2 V	0.1	0.1	0.1	0.1	0.1	0.1	0.8	μA
1.5 V	0.1	0.1	0.1	0.1	0.1	0.1	0.4	μA
1.8 V	0.1	0.1	0.1	0.1	0.1	0.1	0.2	μA
2.5 V	0.1	0.3	0.1	0.1	0.1	0.1	0.1	μA
3.3 V	0.1	1.6	0.8	0.4	0.2	0.1	0.1	μA

10. Dynamic characteristics

Table 9. Typical power dissipation capacitance at $V_{CC(A)} = V_{CC(B)}$ and $T_{amb} = 25\text{ °C}$ [1][2]

Voltages are referenced to GND (ground = 0 V).

Symbol	Parameter	Conditions	$V_{CC(A)} = V_{CC(B)}$						Unit
			0.8 V	1.2 V	1.5 V	1.8 V	2.5 V	3.3 V	
C_{PD}	power dissipation capacitance	A port: (direction nAn to nBn); output enabled	0.2	0.2	0.2	0.2	0.3	0.4	pF
		A port: (direction nAn to nBn); output disabled	0.2	0.2	0.2	0.2	0.3	0.4	pF
		A port: (direction nBn to nAn); output enabled	9	9.7	9.8	10.3	11.7	13.7	pF
		A port: (direction nBn to nAn); output disabled	0.6	0.6	0.6	0.7	0.7	0.7	pF
		B port: (direction nAn to nBn); output enabled	9	9.7	9.8	10.3	11.7	13.7	pF
		B port: (direction nAn to nBn); output disabled	0.6	0.6	0.6	0.7	0.7	0.7	pF
		B port: (direction nBn to nAn); output enabled	0.2	0.2	0.2	0.2	0.3	0.4	pF
		B port: (direction nBn to nAn); output disabled	0.2	0.2	0.2	0.2	0.3	0.4	pF

[1] C_{PD} is used to determine the dynamic power dissipation (P_D in μW).

$$P_D = C_{PD} \times V_{CC}^2 \times f_i \times N + \Sigma(C_L \times V_{CC}^2 \times f_o) \text{ where:}$$

f_i = input frequency in MHz;

f_o = output frequency in MHz;

C_L = load capacitance in pF;

V_{CC} = supply voltage in V;

N = number of inputs switching;

$\Sigma(C_L \times V_{CC}^2 \times f_o)$ = sum of the outputs.

[2] $f_i = 10\text{ MHz}$; $V_i = \text{GND to } V_{CC}$; $t_r = t_f = 1\text{ ns}$; $C_L = 0\text{ pF}$; $R_L = \infty\ \Omega$.

Table 10. Typical dynamic characteristics at $V_{CC(A)} = 0.8\text{ V}$ and $T_{amb} = 25\text{ °C}$

Voltages are referenced to GND (ground = 0 V); for test circuit see [Figure 8](#); for wave forms see [Figure 6](#) and [Figure 7](#)

Symbol	Parameter	Conditions	$V_{CC(B)}$						Unit
			0.8 V	1.2 V	1.5 V	1.8 V	2.5 V	3.3 V	
t_{pd}	propagation delay	nAn to nBn	14.4	7.0	6.2	6.0	5.9	6.0	ns
		nBn to nAn	14.4	12.4	12.1	11.9	11.8	11.8	ns
t_{dis}	disable time	\overline{nOE} to nAn	16.2	16.2	16.2	16.2	16.2	16.2	ns
		\overline{nOE} to nBn	17.6	10.0	9.0	9.1	8.7	9.3	ns
t_{en}	enable time	\overline{nOE} to nAn	21.9	21.9	21.9	21.9	21.9	21.9	ns
		\overline{nOE} to nBn	22.2	11.1	9.8	9.4	9.4	9.6	ns

[1] t_{pd} is the same as t_{PLH} and t_{PHL} ; t_{dis} is the same as t_{PLZ} and t_{PHZ} ; t_{en} is the same as t_{PZL} and t_{PZH} .

Table 11. Typical dynamic characteristics at $V_{CC(B)} = 0.8\text{ V}$ and $T_{amb} = 25\text{ °C}$

Voltages are referenced to GND (ground = 0 V); for test circuit see [Figure 8](#); for wave forms see [Figure 6](#) and [Figure 7](#)

Symbol	Parameter	Conditions	$V_{CC(A)}$						Unit
			0.8 V	1.2 V	1.5 V	1.8 V	2.5 V	3.3 V	
t_{pd}	propagation delay	nAn to nBn	14.4	12.4	12.1	11.9	11.8	11.8	ns
		nBn to nAn	14.4	7.0	6.2	6.0	5.9	6.0	ns
t_{dis}	disable time	\overline{nOE} to nAn	16.2	5.9	4.4	4.2	3.1	3.5	ns
		\overline{nOE} to nBn	17.6	14.2	13.7	13.6	13.3	13.1	ns
t_{en}	enable time	\overline{nOE} to nAn	21.9	6.4	4.4	3.5	2.6	2.3	ns
		\overline{nOE} to nBn	22.2	17.7	17.2	17.0	16.8	16.7	ns

[1] t_{pd} is the same as t_{PLH} and t_{PHL} ; t_{dis} is the same as t_{PLZ} and t_{PHZ} ; t_{en} is the same as t_{PZL} and t_{PZH} .

Table 12. Dynamic characteristics for temperature range –40 °C to +85 °C [1]

Voltages are referenced to GND (ground = 0 V); for test circuit see [Figure 8](#); for wave forms see [Figure 6](#) and [Figure 7](#).

Symbol	Parameter	Conditions	V _{CC(B)}										Unit
			1.2 V ± 0.1 V		1.5 V ± 0.1 V		1.8 V ± 0.15 V		2.5 V ± 0.2 V		3.3 V ± 0.3 V		
			Min	Max	Min	Max	Min	Max	Min	Max	Min	Max	
V_{CC(A)} = 1.1 V to 1.3 V													
t _{pd}	propagation delay	nAn to nBn	0.5	9.2	0.5	6.9	0.5	6.0	0.5	5.1	0.5	4.9	ns
		nBn to nAn	0.5	9.2	0.5	8.7	0.5	8.5	0.5	8.2	0.5	8.0	ns
t _{dis}	disable time	n $\overline{\text{OE}}$ to nAn	1.5	11.6	1.5	11.6	1.5	11.6	1.5	11.6	1.5	11.6	ns
		n $\overline{\text{OE}}$ to nBn	1.5	12.5	1.5	9.7	1.5	9.5	1.0	8.1	1.0	8.9	ns
t _{en}	enable time	n $\overline{\text{OE}}$ to nAn	1.0	14.5	1.0	14.5	1.0	14.5	1.0	14.5	1.0	14.5	ns
		n $\overline{\text{OE}}$ to nBn	1.1	14.9	1.1	11.0	1.1	9.6	1.0	8.1	1.0	7.7	ns
V_{CC(A)} = 1.4 V to 1.6 V													
t _{pd}	propagation delay	nAn to nBn	0.5	8.7	0.5	6.2	0.5	5.2	0.5	4.1	0.5	3.7	ns
		nBn to nAn	0.5	6.9	0.5	6.2	0.5	5.9	0.5	5.6	0.5	5.5	ns
t _{dis}	disable time	n $\overline{\text{OE}}$ to nAn	1.5	9.1	1.5	9.1	1.5	9.1	1.5	9.1	1.5	9.1	ns
		n $\overline{\text{OE}}$ to nBn	1.5	11.4	1.5	8.7	1.5	7.5	1.0	6.5	1.0	6.3	ns
t _{en}	enable time	n $\overline{\text{OE}}$ to nAn	1.0	10.1	1.0	10.1	1.0	10.1	1.0	10.1	1.0	10.1	ns
		n $\overline{\text{OE}}$ to nBn	1.0	13.5	1.0	10.1	0.5	8.1	0.5	5.9	0.5	5.2	ns
V_{CC(A)} = 1.65 V to 1.95 V													
t _{pd}	propagation delay	nAn to nBn	0.5	8.5	0.5	5.9	0.5	4.8	0.5	3.7	0.5	3.3	ns
		nBn to nAn	0.5	6.0	0.5	5.2	0.5	4.8	0.5	4.5	0.5	4.4	ns
t _{dis}	disable time	n $\overline{\text{OE}}$ to nAn	1.5	7.7	1.5	7.7	1.5	7.7	1.5	7.7	1.5	7.7	ns
		n $\overline{\text{OE}}$ to nBn	1.5	11.1	1.5	8.4	1.5	7.1	1.0	5.9	1.0	5.7	ns
t _{en}	enable time	n $\overline{\text{OE}}$ to nAn	1.0	7.8	1.0	7.8	1.0	7.8	1.0	7.8	1.0	7.8	ns
		n $\overline{\text{OE}}$ to nBn	1.0	13.0	1.0	9.2	0.5	7.4	0.5	5.3	0.5	4.5	ns
V_{CC(A)} = 2.3 V to 2.7 V													
t _{pd}	propagation delay	nAn to nBn	0.5	8.2	0.5	5.6	0.5	4.6	0.5	3.3	0.5	2.8	ns
		nBn to nAn	0.5	5.1	0.5	4.1	0.5	3.7	0.5	3.4	0.5	3.2	ns
t _{dis}	disable time	n $\overline{\text{OE}}$ to nAn	1.0	6.1	1.0	6.1	1.0	6.1	1.0	6.1	1.0	6.1	ns
		n $\overline{\text{OE}}$ to nBn	1.0	10.6	1.0	7.9	1.0	6.6	1.0	6.1	1.0	5.2	ns
t _{en}	enable time	n $\overline{\text{OE}}$ to nAn	0.5	5.3	0.5	5.3	0.5	5.3	0.5	5.3	0.5	5.3	ns
		n $\overline{\text{OE}}$ to nBn	0.5	12.5	0.5	9.4	0.5	7.3	0.5	5.1	0.5	4.5	ns
V_{CC(A)} = 3.0 V to 3.6 V													
t _{pd}	propagation delay	nAn to nBn	0.5	8.0	0.5	5.5	0.5	4.4	0.5	3.2	0.5	2.7	ns
		nBn to nAn	0.5	4.9	0.5	3.7	0.5	3.3	0.5	2.9	0.5	2.7	ns
t _{dis}	disable time	n $\overline{\text{OE}}$ to nAn	0.5	5.0	0.5	5.0	0.5	5.0	0.5	5.0	0.5	5.0	ns
		n $\overline{\text{OE}}$ to nBn	1.0	10.3	1.0	7.7	1.0	6.5	1.0	5.2	0.5	5.0	ns
t _{en}	enable time	n $\overline{\text{OE}}$ to nAn	0.5	4.3	0.5	4.3	0.5	4.2	0.5	4.1	0.5	4.0	ns
		n $\overline{\text{OE}}$ to nBn	0.5	12.4	0.5	9.3	0.5	7.2	0.5	4.9	0.5	4.0	ns

[1] t_{pd} is the same as t_{PLH} and t_{PHL}; t_{dis} is the same as t_{PLZ} and t_{PHZ}; t_{en} is the same as t_{PZL} and t_{PZH}.

Table 13. Dynamic characteristics for temperature range –40 °C to +125 °C [1]

Voltages are referenced to GND (ground = 0 V); for test circuit see [Figure 8](#); for wave forms see [Figure 6](#) and [Figure 7](#)

Symbol	Parameter	Conditions	V _{CC(B)}										Unit
			1.2 V ± 0.1 V		1.5 V ± 0.1 V		1.8 V ± 0.15 V		2.5 V ± 0.2 V		3.3 V ± 0.3 V		
			Min	Max	Min	Max	Min	Max	Min	Max	Min	Max	
V_{CC(A)} = 1.1 V to 1.3 V													
t _{pd}	propagation delay	nAn to nBn	0.5	10.2	0.5	7.6	0.5	6.6	0.5	5.7	0.5	5.4	ns
		nBn to nAn	0.5	10.2	0.5	9.6	0.5	9.4	0.5	9.1	0.5	8.8	ns
t _{dis}	disable time	n $\overline{\text{OE}}$ to nAn	1.5	12.8	1.5	12.8	1.5	12.8	1.5	12.8	1.5	12.8	ns
		n $\overline{\text{OE}}$ to nBn	1.5	13.8	1.5	10.7	1.5	10.5	1.0	9.0	1.5	9.8	ns
t _{en}	enable time	n $\overline{\text{OE}}$ to nAn	1.0	16.0	1.0	16.0	1.0	16.0	1.0	16.0	1.0	16.0	ns
		n $\overline{\text{OE}}$ to nBn	1.1	16.4	1.1	12.1	1.1	10.6	1.0	9.0	1.0	8.5	ns
V_{CC(A)} = 1.4 V to 1.6 V													
t _{pd}	propagation delay	nAn to nBn	0.5	9.6	0.5	6.9	0.5	5.8	0.5	4.6	0.5	4.1	ns
		nBn to nAn	0.5	7.6	0.5	6.9	0.5	6.5	0.5	6.2	0.5	6.1	ns
t _{dis}	disable time	n $\overline{\text{OE}}$ to nAn	1.5	10.1	1.5	10.1	1.5	10.1	1.5	10.1	1.5	10.1	ns
		n $\overline{\text{OE}}$ to nBn	1.5	12.6	1.5	9.6	1.5	8.3	1.0	7.2	1.0	7.0	ns
t _{en}	enable time	n $\overline{\text{OE}}$ to nAn	1.0	11.2	1.0	11.2	1.0	11.2	1.0	11.2	1.0	11.2	ns
		n $\overline{\text{OE}}$ to nBn	1.0	14.9	1.0	11.2	0.5	9.0	0.5	6.5	0.5	5.8	ns
V_{CC(A)} = 1.65 V to 1.95 V													
t _{pd}	propagation delay	nAn to nBn	0.5	9.4	0.5	6.5	0.5	5.3	0.5	4.1	0.5	3.7	ns
		nBn to nAn	0.5	6.6	0.5	5.8	0.5	5.3	0.5	5.0	0.5	4.9	ns
t _{dis}	disable time	n $\overline{\text{OE}}$ to nAn	1.5	8.5	1.5	8.5	1.5	8.5	1.5	8.5	1.5	8.5	ns
		n $\overline{\text{OE}}$ to nBn	1.5	12.3	1.5	9.3	1.5	7.9	1.0	6.5	1.0	6.3	ns
t _{en}	enable time	n $\overline{\text{OE}}$ to nAn	1.0	8.6	1.0	8.6	1.0	8.6	1.0	8.6	1.0	8.6	ns
		n $\overline{\text{OE}}$ to nBn	1.0	14.3	1.0	10.2	0.5	8.2	0.5	5.9	0.5	5.0	ns
V_{CC(A)} = 2.3 V to 2.7 V													
t _{pd}	propagation delay	nAn to nBn	0.5	9.1	0.5	6.2	0.5	5.1	0.5	3.7	0.5	3.1	ns
		nBn to nAn	0.5	5.7	0.5	4.6	0.5	4.1	0.5	3.8	0.5	3.6	ns
t _{dis}	disable time	n $\overline{\text{OE}}$ to nAn	1.0	6.8	1.0	6.8	1.0	6.8	1.0	6.8	1.0	6.8	ns
		n $\overline{\text{OE}}$ to nBn	1.0	11.7	1.0	8.7	1.0	7.3	1.0	6.8	1.0	5.8	ns
t _{en}	enable time	n $\overline{\text{OE}}$ to nAn	0.5	5.9	0.5	5.9	0.5	5.9	0.5	5.9	0.5	5.9	ns
		n $\overline{\text{OE}}$ to nBn	0.5	13.8	0.5	10.4	0.5	8.1	0.5	5.7	0.5	5.0	ns
V_{CC(A)} = 3.0 V to 3.6 V													
t _{pd}	propagation delay	nAn to nBn	0.5	8.8	0.5	6.1	0.5	4.9	0.5	3.6	0.5	3.0	ns
		nBn to nAn	0.5	5.4	0.5	4.1	0.5	3.7	0.5	3.2	0.5	3.0	ns
t _{dis}	disable time	n $\overline{\text{OE}}$ to nAn	0.5	5.5	0.5	5.5	0.5	5.5	0.5	5.5	0.5	5.5	ns
		n $\overline{\text{OE}}$ to nBn	1.0	11.4	1.0	8.5	1.0	7.2	1.0	5.8	0.5	5.5	ns
t _{en}	enable time	n $\overline{\text{OE}}$ to nAn	0.5	4.8	0.5	4.8	0.5	4.7	0.5	4.6	0.5	4.4	ns
		n $\overline{\text{OE}}$ to nBn	0.5	13.7	0.5	10.3	0.5	8.0	0.5	5.4	0.5	4.4	ns

[1] t_{pd} is the same as t_{PLH} and t_{PHL}; t_{dis} is the same as t_{PLZ} and t_{PHZ}; t_{en} is the same as t_{PZL} and t_{PZH}.

11. Waveforms

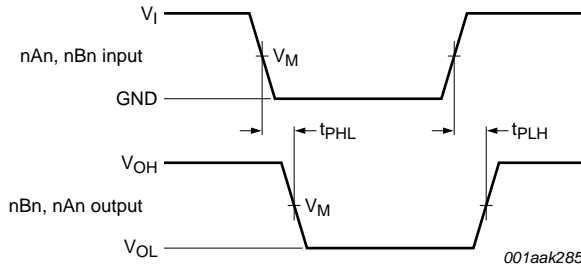

Measurement points are given in [Table 14](#).
 VOL and VOH are typical output voltage levels that occur with the output load.

Fig 6. The data input (nAn, nBn) to output (nBn, nAn) propagation delay times

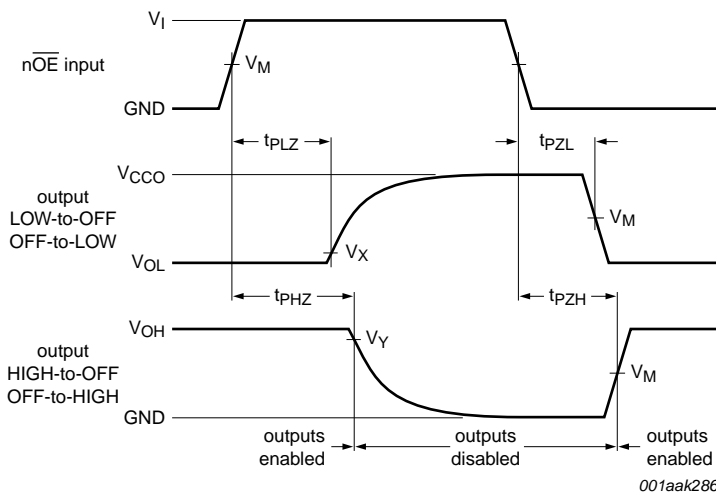

Measurement points are given in [Table 14](#).
 VOL and VOH are typical output voltage levels that occur with the output load.

Fig 7. Enable and disable times

Table 14. Measurement points

Supply voltage	Input ^[1]	Output ^[2]		
V _{CC(A)} , V _{CC(B)}	V _M	V _M	V _X	V _Y
0.8 V to 1.6 V	0.5V _{CCI}	0.5V _{CCO}	V _{OL} + 0.1 V	V _{OH} - 0.1 V
1.65 V to 2.7 V	0.5V _{CCI}	0.5V _{CCO}	V _{OL} + 0.15 V	V _{OH} - 0.15 V
3.0 V to 3.6 V	0.5V _{CCI}	0.5V _{CCO}	V _{OL} + 0.3 V	V _{OH} - 0.3 V

[1] V_{CCI} is the supply voltage associated with the data input port.
 [2] V_{CCO} is the supply voltage associated with the output port.

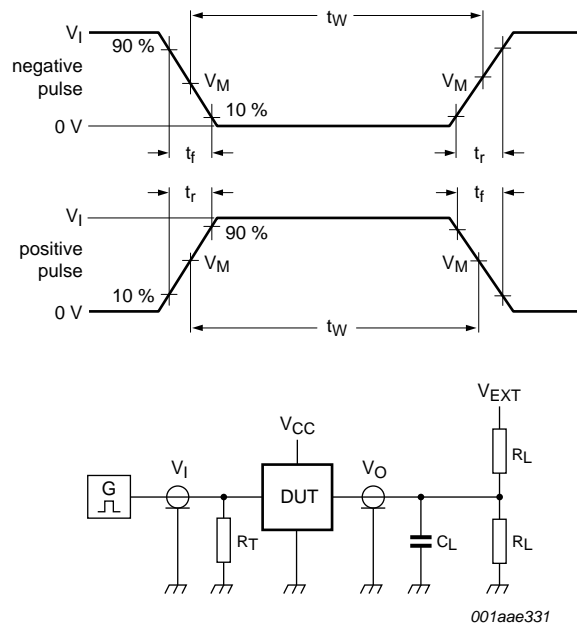

Test data is given in [Table 15](#).
 R_L = Load resistance.
 C_L = Load capacitance including jig and probe capacitance.
 R_T = Termination resistance.
 V_{EXT} = External voltage for measuring switching times.

Fig 8. Test circuit for measuring switching times

Table 15. Test data

Supply voltage	Input		Load		V_{EXT}		
	$V_{CC(A)}$, $V_{CC(B)}$	V_I ^[1]	$\Delta t/\Delta V$ ^[2]	C_L	R_L	t_{PLH} , t_{PHL}	t_{PZH} , t_{PHZ}
0.8 V to 1.6 V	V_{CCI}	≤ 1.0 ns/V	15 pF	2 k Ω	open	GND	$2V_{CCO}$
1.65 V to 2.7 V	V_{CCI}	≤ 1.0 ns/V	15 pF	2 k Ω	open	GND	$2V_{CCO}$
3.0 V to 3.6 V	V_{CCI}	≤ 1.0 ns/V	15 pF	2 k Ω	open	GND	$2V_{CCO}$

- [1] V_{CCI} is the supply voltage associated with the data input port.
- [2] $dV/dt \geq 1.0$ V/ns
- [3] V_{CCO} is the supply voltage associated with the output port.

12. Typical propagation delay characteristics

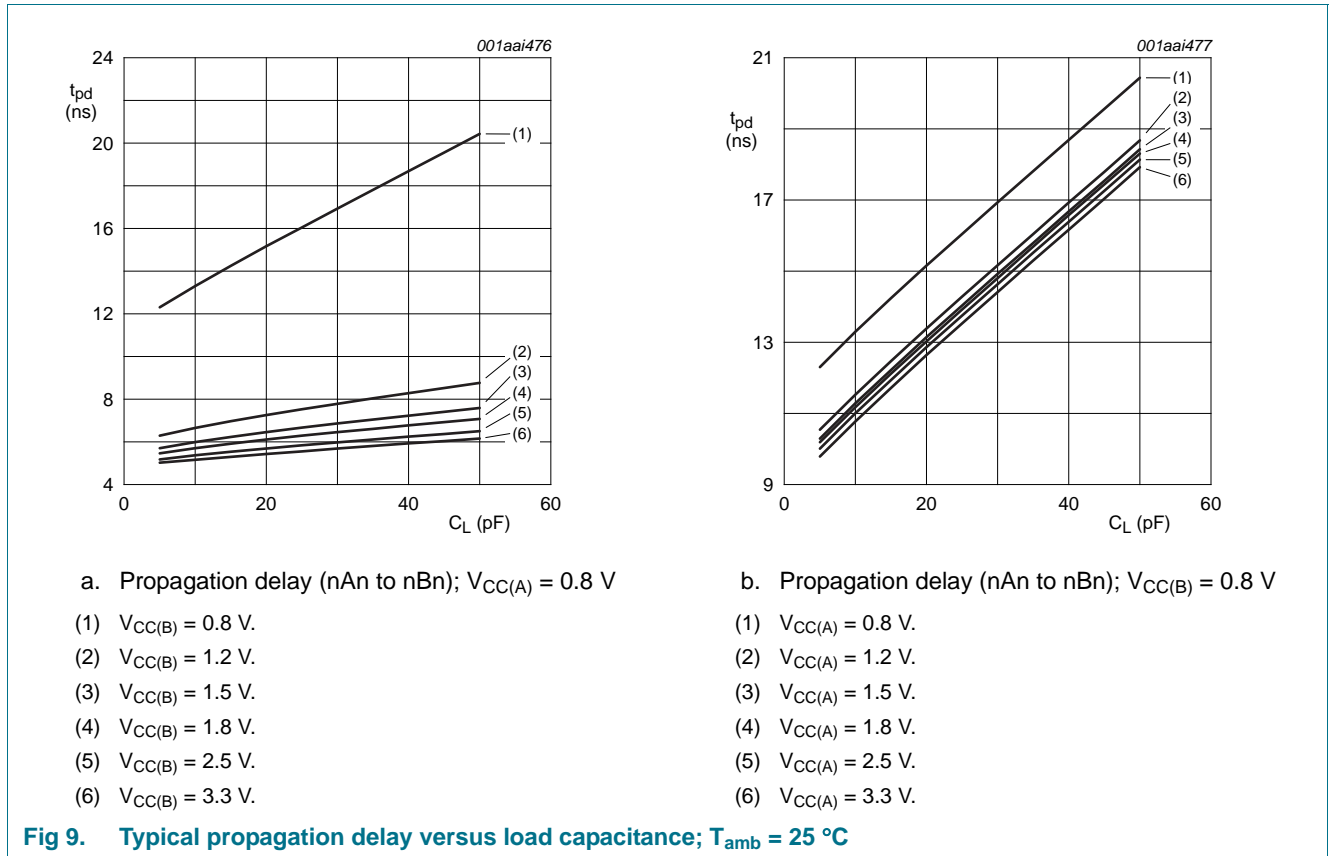

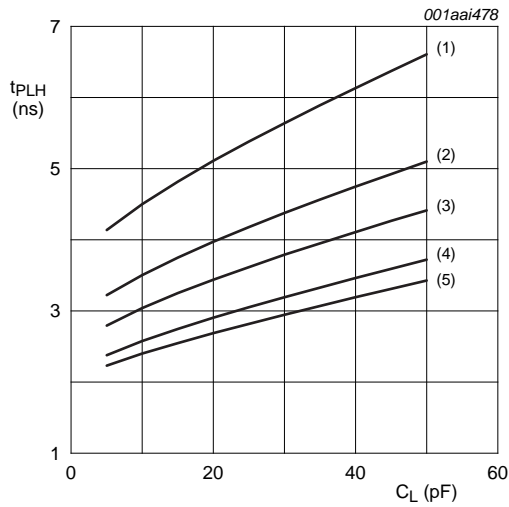

a. LOW to HIGH propagation delay (nAn to nBn);
 $V_{CC(A)} = 1.2\text{ V}$

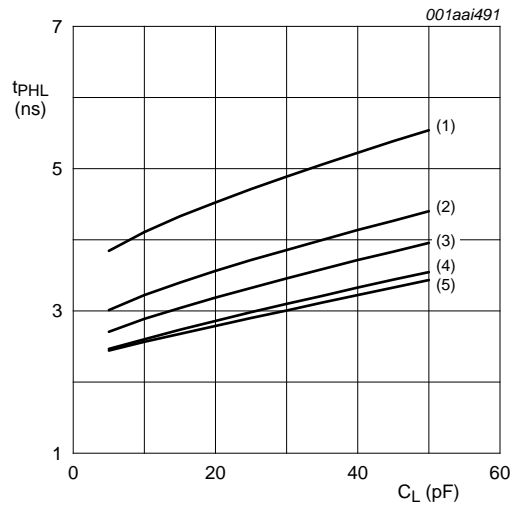

b. HIGH to LOW propagation delay (nAn to nBn);
 $V_{CC(A)} = 1.2\text{ V}$

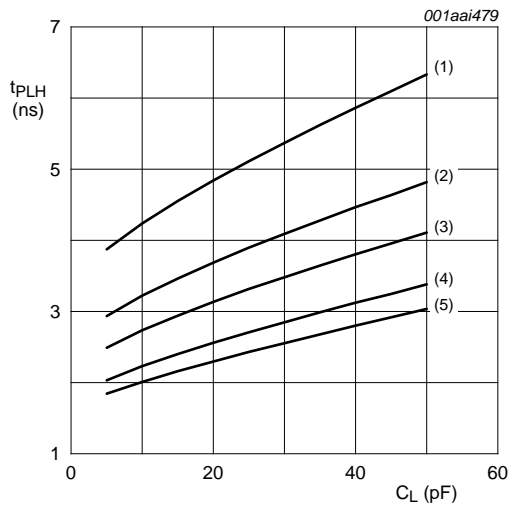

c. LOW to HIGH propagation delay (nAn to nBn);
 $V_{CC(A)} = 1.5\text{ V}$

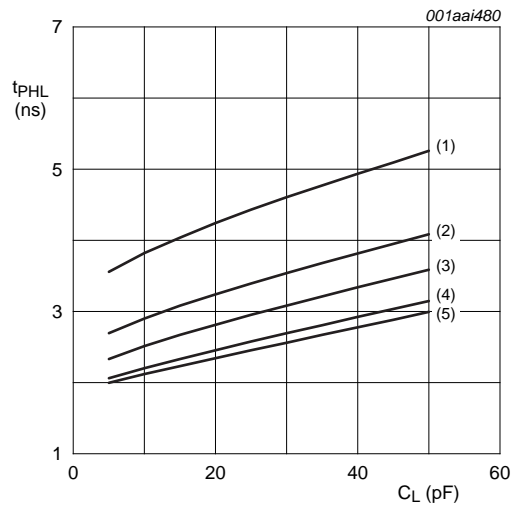

d. HIGH to LOW propagation delay (nAn to nBn);
 $V_{CC(A)} = 1.5\text{ V}$

- (1) $V_{CC(B)} = 1.2\text{ V}$.
- (2) $V_{CC(B)} = 1.5\text{ V}$.
- (3) $V_{CC(B)} = 1.8\text{ V}$.
- (4) $V_{CC(B)} = 2.5\text{ V}$.
- (5) $V_{CC(B)} = 3.3\text{ V}$.

Fig 10. Typical propagation delay versus load capacitance; $T_{amb} = 25\text{ }^\circ\text{C}$

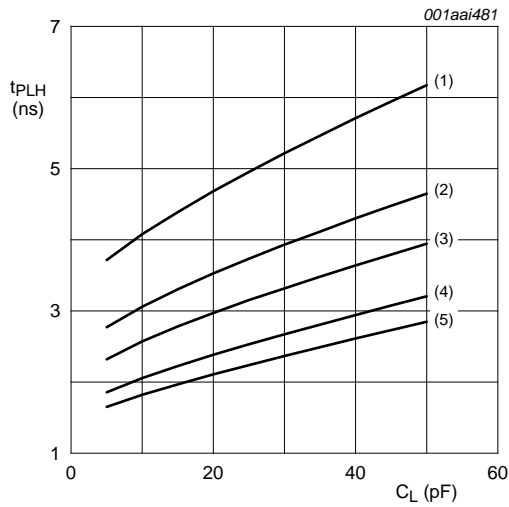

a. LOW to HIGH propagation delay (nAn to nBn);
 $V_{CC(A)} = 1.8\text{ V}$

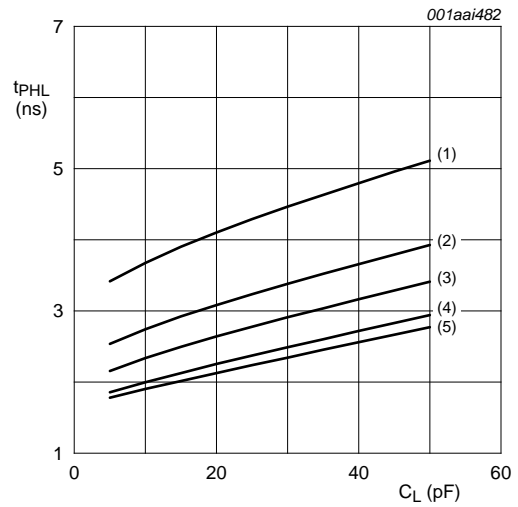

b. HIGH to LOW propagation delay (nAn to nBn);
 $V_{CC(A)} = 1.8\text{ V}$

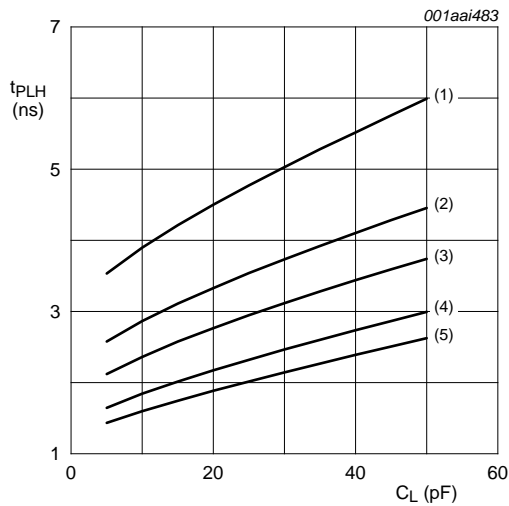

c. LOW to HIGH propagation delay (nAn to nBn);
 $V_{CC(A)} = 2.5\text{ V}$

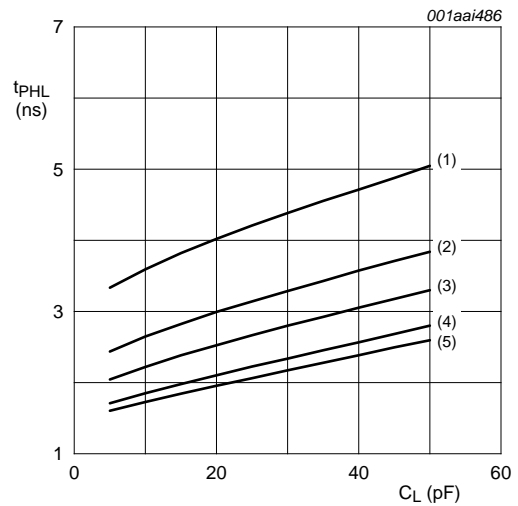

d. HIGH to LOW propagation delay (nAn to nBn);
 $V_{CC(A)} = 2.5\text{ V}$

- (1) $V_{CC(B)} = 1.2\text{ V}$.
- (2) $V_{CC(B)} = 1.5\text{ V}$.
- (3) $V_{CC(B)} = 1.8\text{ V}$.
- (4) $V_{CC(B)} = 2.5\text{ V}$.
- (5) $V_{CC(B)} = 3.3\text{ V}$.

Fig 11. Typical propagation delay versus load capacitance; $T_{amb} = 25\text{ }^\circ\text{C}$

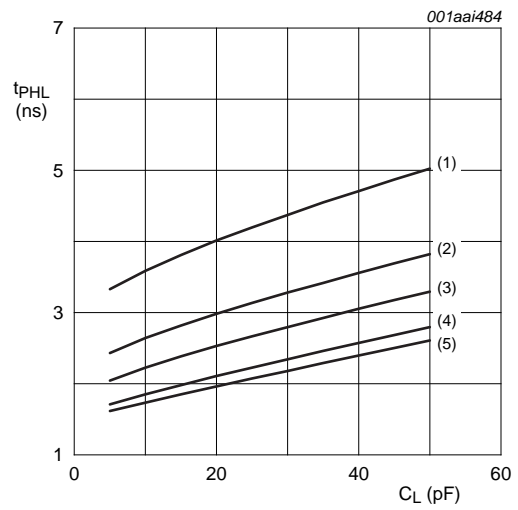
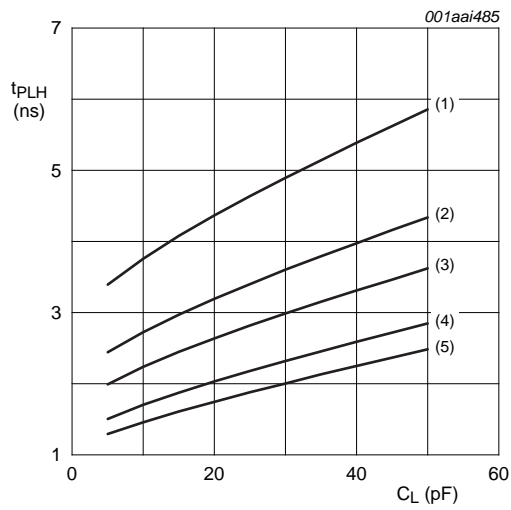

a. LOW to HIGH propagation delay (nAn to nBn);
 $V_{CC(A)} = 3.3\text{ V}$

b. HIGH to LOW propagation delay (nAn to nBn);
 $V_{CC(A)} = 3.3\text{ V}$

- (1) $V_{CC(B)} = 1.2\text{ V}$.
- (2) $V_{CC(B)} = 1.5\text{ V}$.
- (3) $V_{CC(B)} = 1.8\text{ V}$.
- (4) $V_{CC(B)} = 2.5\text{ V}$.
- (5) $V_{CC(B)} = 3.3\text{ V}$.

Fig 12. Typical propagation delay versus load capacitance; $T_{amb} = 25\text{ °C}$

13. Package outline

TSSOP48: plastic thin shrink small outline package; 48 leads; body width 6.1 mm

SOT362-1

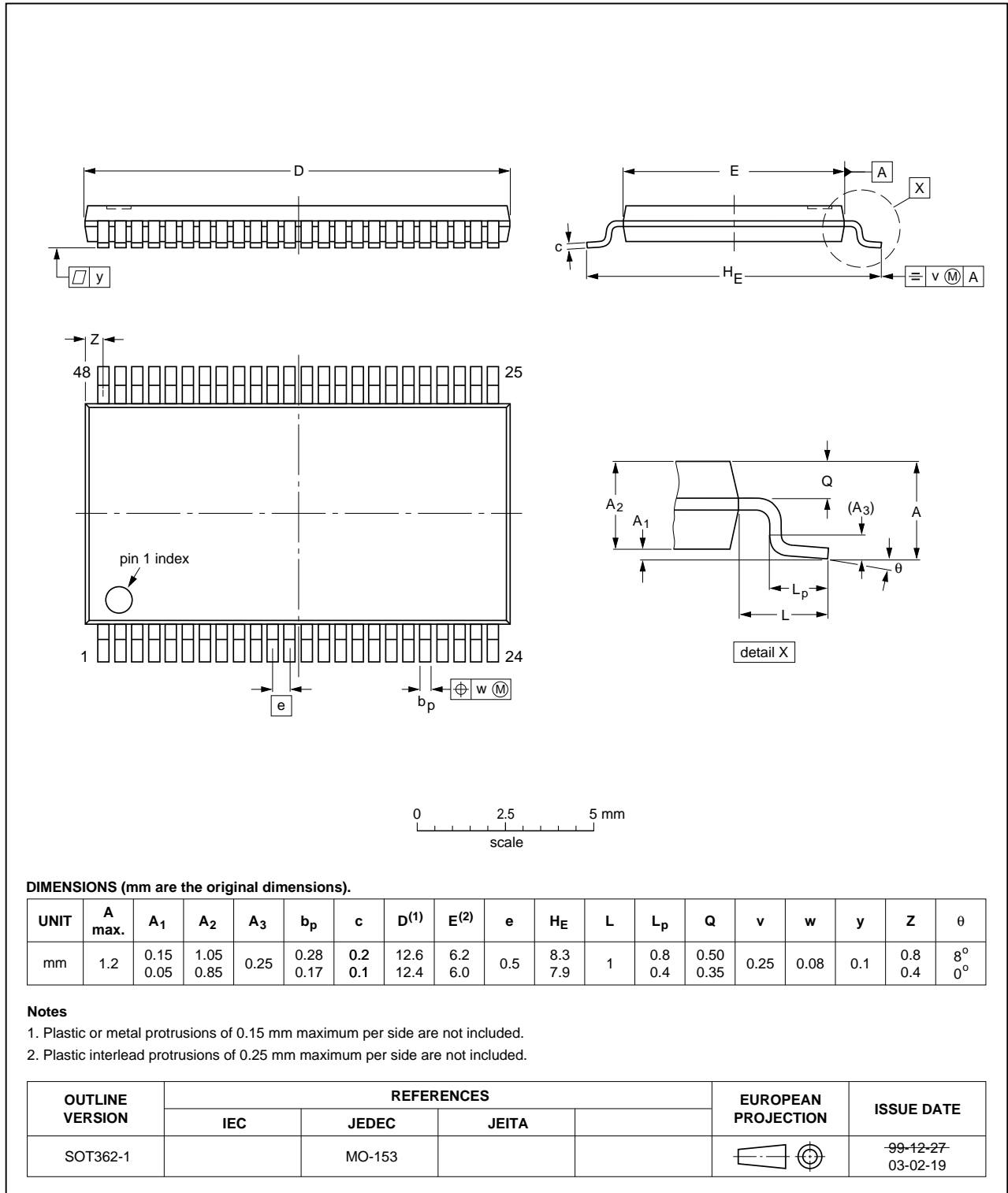

Fig 13. Package outline SOT362-1 (TSSOP48)

TSSOP48: plastic thin shrink small outline package; 48 leads;
body width 4.4 mm; lead pitch 0.4 mm

SOT480-1

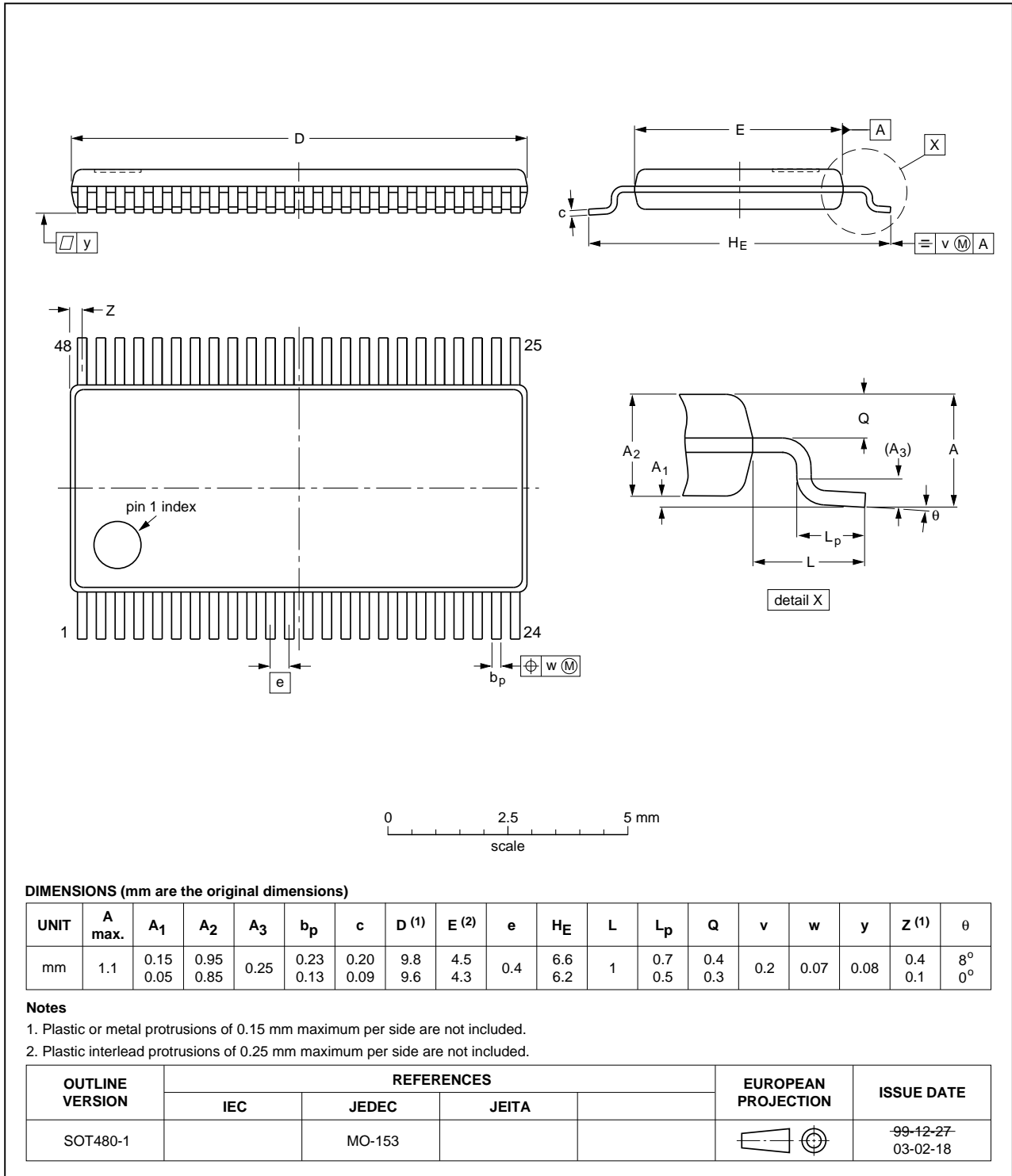

Fig 14. Package outline SOT480-1 (TSSOP48)

VFBGA56: plastic very thin fine-pitch ball grid array package; 56 balls; body 4.5 x 7 x 0.65 mm

SOT702-1

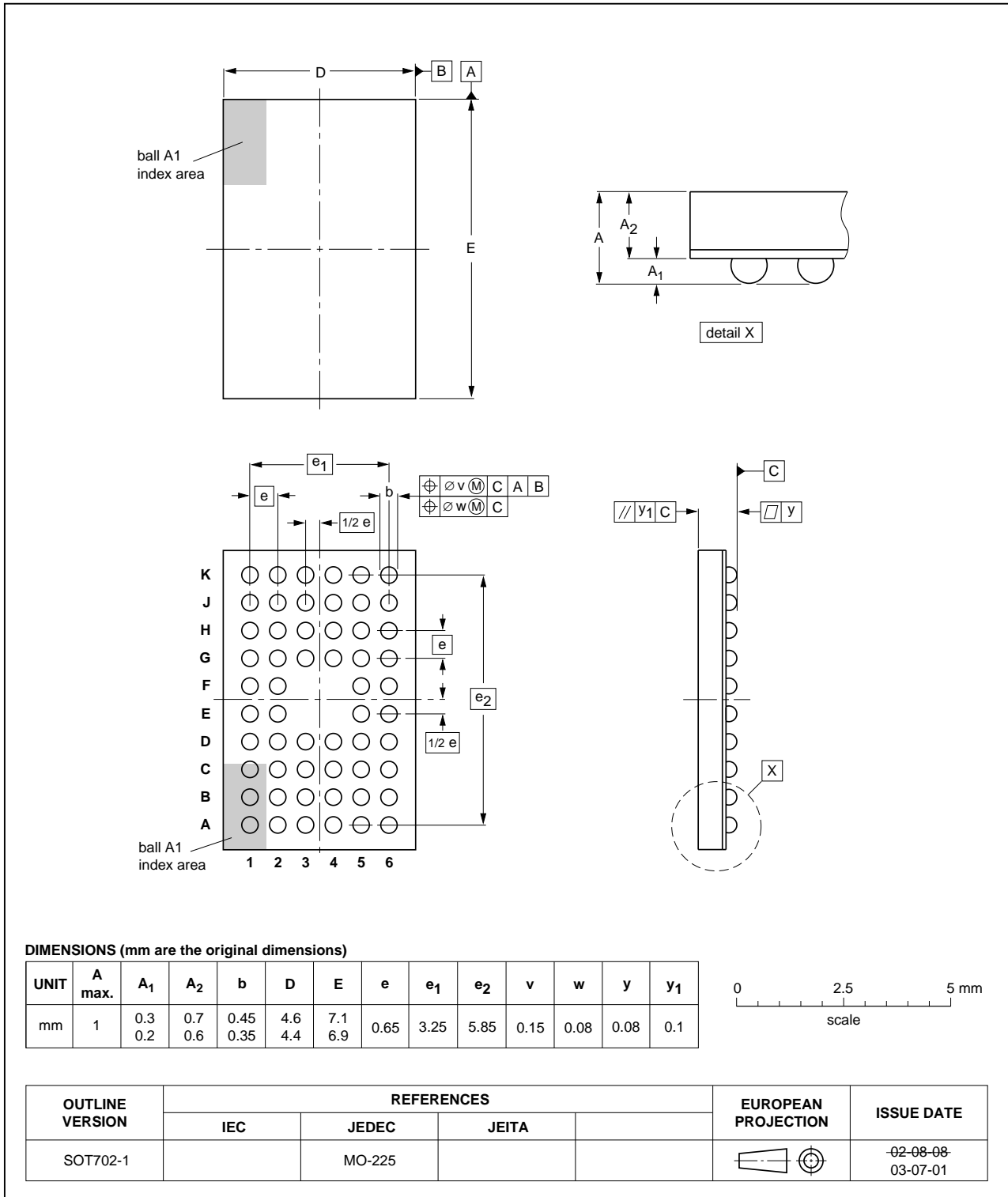

Fig 15. Package outline SOT702-1 (VFBGA56)

HXQFN60: plastic compatible thermal enhanced extremely thin quad flat package; no leads; 60 terminals; body 4 x 6 x 0.5 mm

SOT1134-2

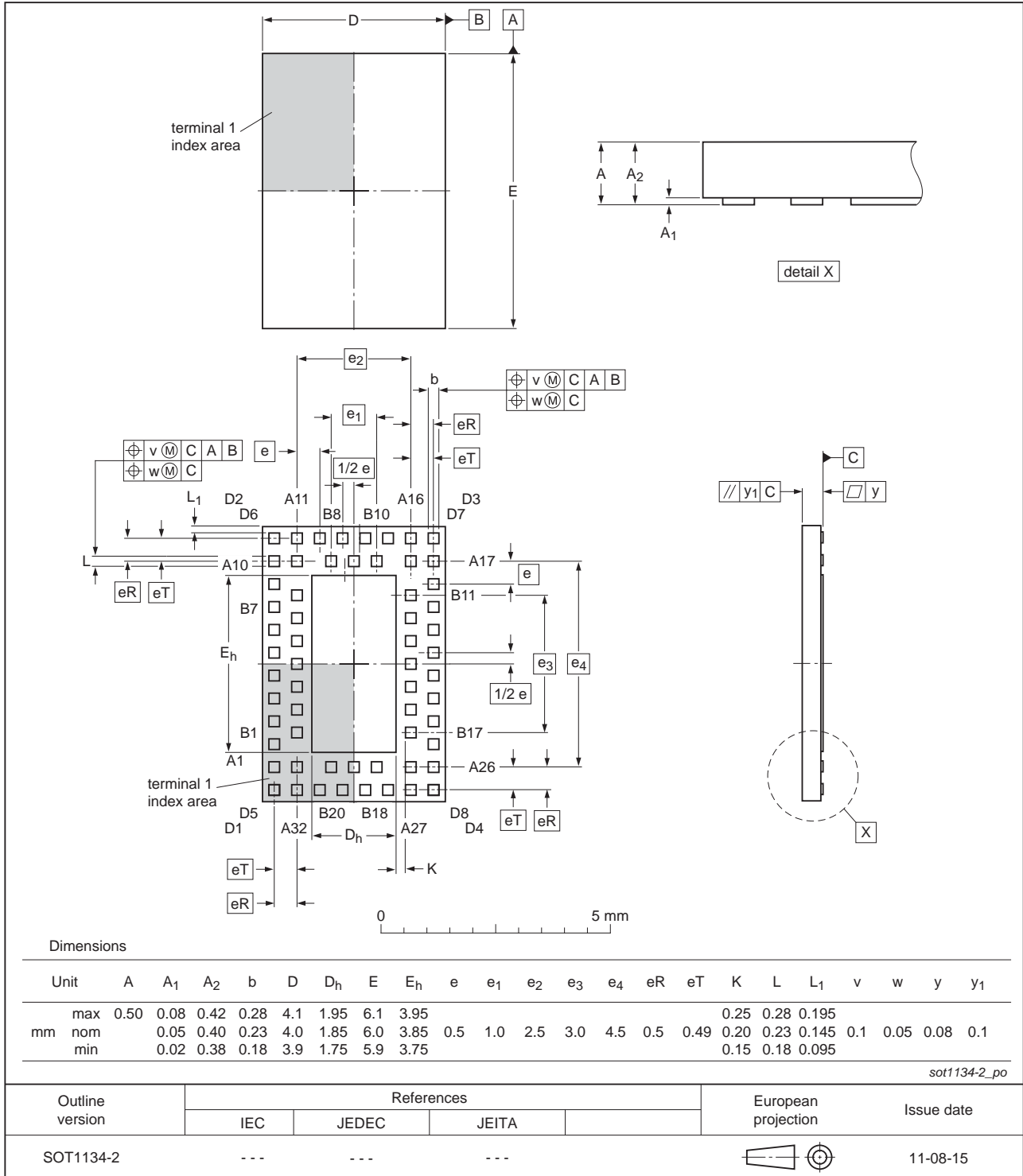

Fig 16. Package outline SOT1134-2 (HXQFN60)

14. Abbreviations

Table 16. Abbreviations

Acronym	Description
CDM	Charged Device Model
DUT	Device Under Test
ESD	ElectroStatic Discharge
HBM	Human Body Model
MM	Machine Model

15. Revision history

Table 17. Revision history

Document ID	Release date	Data sheet status	Change notice	Supersedes
74AVC16T245 v.5	20120309	Product data sheet	-	74AVC16T245 v.4
Modifications:	<ul style="list-style-type: none"> For type number 74AVC16T245BX the sot code has changed to SOT1134-2. 			
74AVC16T245 v.4	20111208	Product data sheet	-	74AVC16T245 v.3
Modifications:	<ul style="list-style-type: none"> Legal pages updated. 			
74AVC16T245 v.3	20110609	Product data sheet	-	74AVC16T245 v.2
74AVC16T245 v.2	20100330	Product data sheet	-	74AVC16T245 v.1
74AVC16T245 v.1	20091001	Product data sheet	-	-

16. Legal information

16.1 Data sheet status

Document status ^{[1][2]}	Product status ^[3]	Definition
Objective [short] data sheet	Development	This document contains data from the objective specification for product development.
Preliminary [short] data sheet	Qualification	This document contains data from the preliminary specification.
Product [short] data sheet	Production	This document contains the product specification.

[1] Please consult the most recently issued document before initiating or completing a design.

[2] The term 'short data sheet' is explained in section "Definitions".

[3] The product status of device(s) described in this document may have changed since this document was published and may differ in case of multiple devices. The latest product status information is available on the Internet at URL <http://www.nxp.com>.

16.2 Definitions

Draft — The document is a draft version only. The content is still under internal review and subject to formal approval, which may result in modifications or additions. NXP Semiconductors does not give any representations or warranties as to the accuracy or completeness of information included herein and shall have no liability for the consequences of use of such information.

Short data sheet — A short data sheet is an extract from a full data sheet with the same product type number(s) and title. A short data sheet is intended for quick reference only and should not be relied upon to contain detailed and full information. For detailed and full information see the relevant full data sheet, which is available on request via the local NXP Semiconductors sales office. In case of any inconsistency or conflict with the short data sheet, the full data sheet shall prevail.

Product specification — The information and data provided in a Product data sheet shall define the specification of the product as agreed between NXP Semiconductors and its customer, unless NXP Semiconductors and customer have explicitly agreed otherwise in writing. In no event however, shall an agreement be valid in which the NXP Semiconductors product is deemed to offer functions and qualities beyond those described in the Product data sheet.

16.3 Disclaimers

Limited warranty and liability — Information in this document is believed to be accurate and reliable. However, NXP Semiconductors does not give any representations or warranties, expressed or implied, as to the accuracy or completeness of such information and shall have no liability for the consequences of use of such information. NXP Semiconductors takes no responsibility for the content in this document if provided by an information source outside of NXP Semiconductors.

In no event shall NXP Semiconductors be liable for any indirect, incidental, punitive, special or consequential damages (including - without limitation - lost profits, lost savings, business interruption, costs related to the removal or replacement of any products or rework charges) whether or not such damages are based on tort (including negligence), warranty, breach of contract or any other legal theory.

Notwithstanding any damages that customer might incur for any reason whatsoever, NXP Semiconductors' aggregate and cumulative liability towards customer for the products described herein shall be limited in accordance with the *Terms and conditions of commercial sale* of NXP Semiconductors.

Right to make changes — NXP Semiconductors reserves the right to make changes to information published in this document, including without limitation specifications and product descriptions, at any time and without notice. This document supersedes and replaces all information supplied prior to the publication hereof.

Suitability for use — NXP Semiconductors products are not designed, authorized or warranted to be suitable for use in life support, life-critical or safety-critical systems or equipment, nor in applications where failure or malfunction of an NXP Semiconductors product can reasonably be expected to result in personal injury, death or severe property or environmental damage. NXP Semiconductors and its suppliers accept no liability for inclusion and/or use of NXP Semiconductors products in such equipment or applications and therefore such inclusion and/or use is at the customer's own risk.

Applications — Applications that are described herein for any of these products are for illustrative purposes only. NXP Semiconductors makes no representation or warranty that such applications will be suitable for the specified use without further testing or modification.

Customers are responsible for the design and operation of their applications and products using NXP Semiconductors products, and NXP Semiconductors accepts no liability for any assistance with applications or customer product design. It is customer's sole responsibility to determine whether the NXP Semiconductors product is suitable and fit for the customer's applications and products planned, as well as for the planned application and use of customer's third party customer(s). Customers should provide appropriate design and operating safeguards to minimize the risks associated with their applications and products.

NXP Semiconductors does not accept any liability related to any default, damage, costs or problem which is based on any weakness or default in the customer's applications or products, or the application or use by customer's third party customer(s). Customer is responsible for doing all necessary testing for the customer's applications and products using NXP Semiconductors products in order to avoid a default of the applications and the products or of the application or use by customer's third party customer(s). NXP does not accept any liability in this respect.

Limiting values — Stress above one or more limiting values (as defined in the Absolute Maximum Ratings System of IEC 60134) will cause permanent damage to the device. Limiting values are stress ratings only and (proper) operation of the device at these or any other conditions above those given in the Recommended operating conditions section (if present) or the Characteristics sections of this document is not warranted. Constant or repeated exposure to limiting values will permanently and irreversibly affect the quality and reliability of the device.

Terms and conditions of commercial sale — NXP Semiconductors products are sold subject to the general terms and conditions of commercial sale, as published at <http://www.nxp.com/profile/terms>, unless otherwise agreed in a valid written individual agreement. In case an individual agreement is concluded only the terms and conditions of the respective agreement shall apply. NXP Semiconductors hereby expressly objects to applying the customer's general terms and conditions with regard to the purchase of NXP Semiconductors products by customer.

No offer to sell or license — Nothing in this document may be interpreted or construed as an offer to sell products that is open for acceptance or the grant, conveyance or implication of any license under any copyrights, patents or other industrial or intellectual property rights.

Export control — This document as well as the item(s) described herein may be subject to export control regulations. Export might require a prior authorization from competent authorities.

Non-automotive qualified products — Unless this data sheet expressly states that this specific NXP Semiconductors product is automotive qualified, the product is not suitable for automotive use. It is neither qualified nor tested in accordance with automotive testing or application requirements. NXP Semiconductors accepts no liability for inclusion and/or use of non-automotive qualified products in automotive equipment or applications.

In the event that customer uses the product for design-in and use in automotive applications to automotive specifications and standards, customer (a) shall use the product without NXP Semiconductors' warranty of the

product for such automotive applications, use and specifications, and (b) whenever customer uses the product for automotive applications beyond NXP Semiconductors' specifications such use shall be solely at customer's own risk, and (c) customer fully indemnifies NXP Semiconductors for any liability, damages or failed product claims resulting from customer design and use of the product for automotive applications beyond NXP Semiconductors' standard warranty and NXP Semiconductors' product specifications.

16.4 Trademarks

Notice: All referenced brands, product names, service names and trademarks are the property of their respective owners.

17. Contact information

For more information, please visit: <http://www.nxp.com>

For sales office addresses, please send an email to: salesaddresses@nxp.com

18. Contents

1	General description	1
2	Features and benefits	1
3	Ordering information	2
4	Functional diagram	2
5	Pinning information	4
5.1	Pinning	4
5.2	Pin description	6
6	Functional description	6
7	Limiting values	7
8	Recommended operating conditions	7
9	Static characteristics	8
10	Dynamic characteristics	11
11	Waveforms	15
12	Typical propagation delay characteristics ..	17
13	Package outline	21
14	Abbreviations	25
15	Revision history	25
16	Legal information	26
16.1	Data sheet status	26
16.2	Definitions	26
16.3	Disclaimers	26
16.4	Trademarks	27
17	Contact information	27
18	Contents	28

Please be aware that important notices concerning this document and the product(s) described herein, have been included in section 'Legal information'.

© NXP B.V. 2012.

All rights reserved.

For more information, please visit: <http://www.nxp.com>

For sales office addresses, please send an email to: salesaddresses@nxp.com

Date of release: 9 March 2012

Document identifier: 74AVC16T245