

Current Transducer LF 305-S

$I_{PN} = 300 \text{ A}$

For the electronic measurement of currents: DC, AC, pulsed..., with galvanic isolation between the primary circuit (high power) and the secondary circuit (electronic circuit).



16167

Electrical data

I_{PN}	Primary nominal current rms	300	A				
I_{PM}	Primary current, measuring range	0 .. ± 500	A				
R_M	Measuring resistance @	$T_A = 70^\circ\text{C}$		$T_A = 85^\circ\text{C}$			
			$R_{M \min}$	$R_{M \max}$	$R_{M \min}$	$R_{M \max}$	
		with $\pm 12 \text{ V}$	@ $\pm 300 \text{ A}_{\max}$	0	37	0	35
			@ $\pm 500 \text{ A}_{\max}$	0	10	0	8
		with $\pm 15 \text{ V}$	@ $\pm 300 \text{ A}_{\max}$	0	56	0	54
			@ $\pm 500 \text{ A}_{\max}$	0	21	0	19
	with $\pm 20 \text{ V}$	@ $\pm 300 \text{ A}_{\max}$	0	88	0	86	
		@ $\pm 500 \text{ A}_{\max}$	0	40	0	38	
I_{SN}	Secondary nominal current rms	150	mA				
K_N	Conversion ratio	1 : 2000					
V_C	Supply voltage ($\pm 5 \%$)	$\pm 12 \dots 20$	V				
I_C	Current consumption	26 (@ $\pm 20\text{V}$)+ I_S	mA				

Accuracy - Dynamic performance data

X_G	Overall accuracy @ I_{PN} , $T_A = 25^\circ\text{C}$	± 0.5	%
ϵ_L	Linearity error	< 0.1	%
I_O	Offset current @ $I_p = 0$, $T_A = 25^\circ\text{C}$	Typ	Max
I_{OM}	Magnetic offset current ¹⁾ @ $I_p=0$ and specified R_M after an overload of $3 \times I_{PN}$		± 0.2
I_{OT}	Temperature variation of I_O	- $40^\circ\text{C} \dots + 85^\circ\text{C}$	± 0.2
		- $10^\circ\text{C} \dots + 70^\circ\text{C}$	± 0.1
t_{ra}	Reaction time to 10 % of I_{PN}	< 500	ns
t_r	Response time ²⁾ to 90 % of I_{PN} step	< 1	μs
di/dt	di/dt accurately followed	> 100	A/ μs
BW	Frequency bandwidth (-1 dB)	DC .. 100	kHz

General data

T_A	Ambient operating temperature	- 40 .. + 85	$^\circ\text{C}$
T_S	Ambient storage temperature	- 40 .. + 85	$^\circ\text{C}$
R_S	Secondary coil resistance @	$T_A = 70^\circ\text{C}$	30
		$T_A = 85^\circ\text{C}$	32
m	Mass	95	g
	Standards	EN 50178:1997	

Features

- Closed loop (compensated) current transducer using the Hall effect
- Isolated plastic case recognized according to UL 94-V0.

Advantages

- Excellent accuracy
- Very good linearity
- Low temperature drift
- Optimized response time
- Wide frequency bandwidth
- No insertion losses
- High immunity to external interference
- Current overload capability.

Applications

- AC variable speed drives and servo motor drives
- Static converters for DC motor drives
- Battery supplied applications
- Uninterruptible Power Supplies (UPS)
- Switched Mode Power Supplies (SMPS)
- Power supplies for welding applications.

Application domains

- Industrial.

Notes:¹⁾ The result of the coercive field of the magnetic circuit

²⁾ With a di/dt of 100 A/ μs .

Current Transducer LF 305-S

Isolation characteristics

V_d	Rms voltage for AC isolation test, 50 Hz, 1 min	3.8	kV
\hat{V}_w	Impulse withstand voltage 1.2/50 μ s	10	kV
		Min	
dCp	Creepage distance	11.9	mm
dCI	Clearance distance	11.5	mm
CTI	Comparative Tracking Index (group IIIa)	175	

Applications examples

According to EN 50178 and IEC 61010-1 standards and following conditions:

- Over voltage category OV 2
- Pollution degree PD2
- Non-uniform field

	EN 50178	IEC 61010-1
dCp, dCI, \hat{V}_w	Rated insulation voltage	Nominal voltage
Basic insulation	1000 V	1000 V
Reinforced insulation	500 V	500 V

Safety



This transducer must be used in electric/electronic equipment with respect to applicable standards and safety requirements in accordance with the manufacturer's operating instructions.



Caution, risk of electrical shock

When operating the transducer, certain parts of the module can carry hazardous voltage (eg. primary busbar, power supply).

Ignoring this warning can lead to injury and/or cause serious damage.

This transducer is a build-in device, whose conducting parts must be inaccessible after installation.

A protective housing or additional shield could be used.

Main supply must be able to be disconnected.

Dimensions LF 305-S (in mm.)

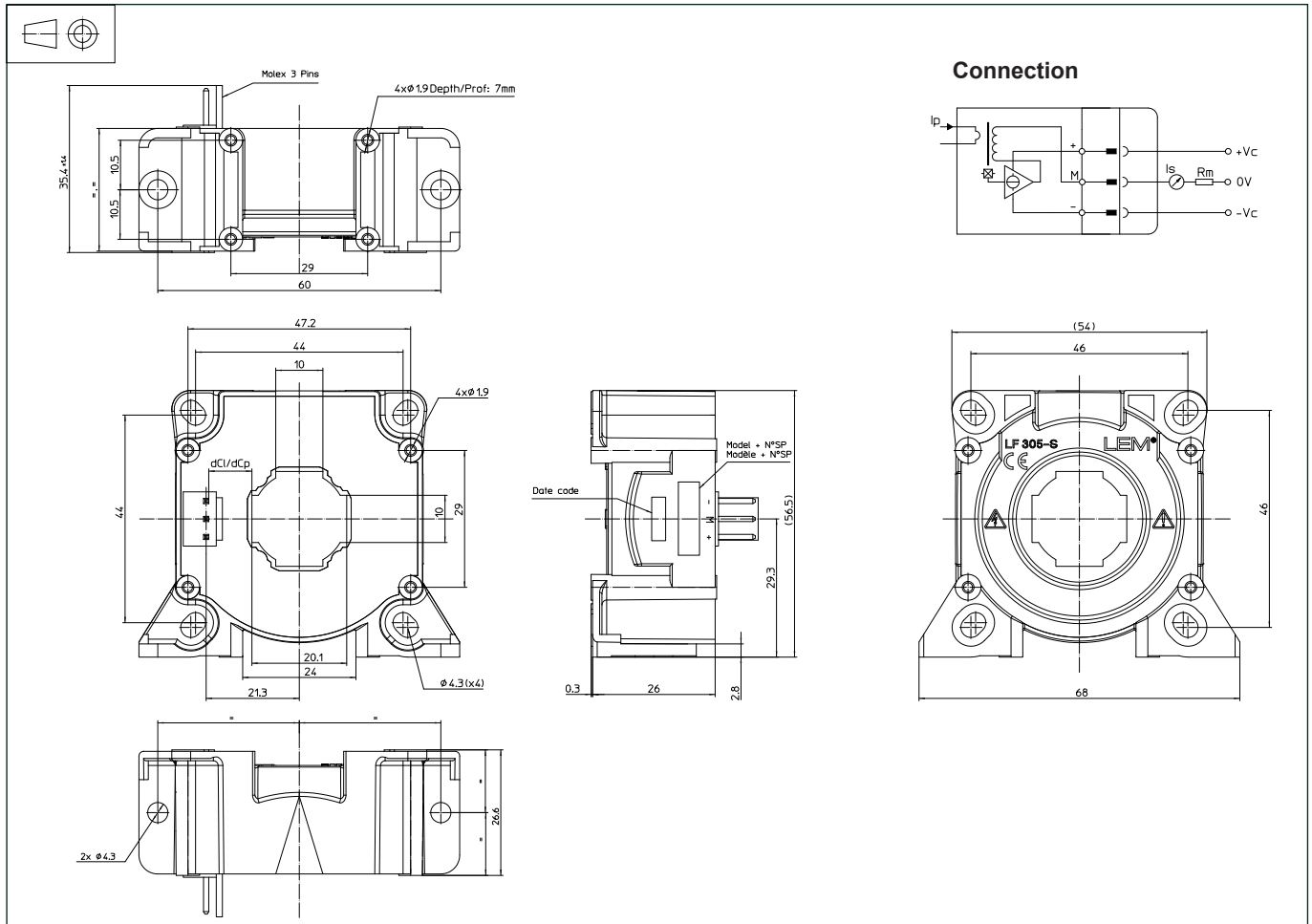

Mechanical characteristics

- General tolerance ± 0.5 mm
- Transducer fastening
 - Vertical position
 - 2 holes $\text{Ø} 4.3$ mm
 - 2 M4 steel screws
 - Recommended fastening torque 3.2 Nm
 - or
 - 4 holes $\text{Ø} 1.9$ mm, depth: 7 mm
 - 4 PTKA 25 screws length: 6 mm
 - Recommended fastening torque 0.7 Nm
 - Horizontal position
 - 4 holes $\text{Ø} 4.3$ mm
 - 4 M4 steel screws
 - Recommended fastening torque 3.2 Nm
 - or
 - 4 holes $\text{Ø} 1.9$ mm crossing
 - 4 PTKA 25 screws, length: 10 mm
 - Recommended fastening torque 0.75 Nm
- Primary through-hole $\text{Ø} 20.1$ mm
- Connection of secondary
 - Molex 6410
 - 3 Tin plated pins

Remarks

- I_s is positive when I_p flows in the direction of the arrow.
- Temperature of the primary conductor should not exceed 100°C .
- Dynamic performances (di/dt and response time) are best with a single bar completely filling the primary hole.
- This is a standard model. For different versions (supply voltage, turns ratios, unidirectional measurements ...), please contact us.