

Current Transducer LT 1005-T

For the electronic measurement of currents: DC, AC, pulsed..., with galvanic isolation between the primary circuit (high power) and the secondary circuit (electronic circuit).

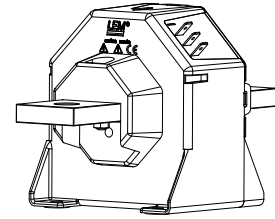

$$I_{PN} = 1000 \text{ A}$$



Electrical data

I_{PN}	Primary nominal current rms	1000	A				
I_{PM}	Primary current, measuring range	0 .. ± 2000	A				
R_M	Measuring resistance @	$T_A = 70^\circ\text{C}$		$T_A = 85^\circ\text{C}$			
			$R_{M \min}$	$R_{M \max}$	$R_{M \min}$	$R_{M \max}$	
		with $\pm 15 \text{ V}$	@ $\pm 1000 \text{ A}_{\max}$	0	22.5	0	18.5
			@ $\pm 1200 \text{ A}_{\max}$	0	11	0	8
		with $\pm 24 \text{ V}$	@ $\pm 1000 \text{ A}_{\max}$	0	65	0	62
			@ $\pm 2000 \text{ A}_{\max}$	0	10	0	7
I_{SN}	Secondary nominal current rms	200	mA				
K_N	Conversion ratio	1 : 5000					
V_C	Supply voltage ($\pm 5 \%$)	$\pm 15 \dots 24$	V				
I_C	Current consumption	30 (@ $\pm 24\text{V}$) + I_S	mA				

Accuracy - Dynamic performance data

X_G	Overall accuracy @ I_{PN} , $T_A = 25^\circ\text{C}$	± 0.4	%
ϵ_L	Linearity error	< 0.1	%
I_O	Offset current @ $I_p = 0$, $T_A = 25^\circ\text{C}$	Typ	Max
I_{OM}	Magnetic offset current @ $I_p = 0$, and specified R_M , after an overload of $3 \times I_{PN}$		± 0.4 mA
I_{OT}	Temperature variation of I_O - $10^\circ\text{C} \dots +85^\circ\text{C}$	± 0.3	± 0.5 mA
t_r	Response time ¹⁾ to 90 % of I_{PN} step	< 1	μs
di/dt	di/dt accurately followed	> 50	A/ μs
BW	Frequency bandwidth (-1 dB)	DC .. 150	kHz

General data

T_A	Ambient operating temperature	-10 .. +85	$^\circ\text{C}$
T_S	Ambient storage temperature	-25 .. +100	$^\circ\text{C}$
R_S	Secondary coil resistance @	$T_A = 70^\circ\text{C}$	43 Ω
		$T_A = 85^\circ\text{C}$	46 Ω
m	Mass	1.27	kg
	Standards	EN 50178: 1997	

Features

- Closed loop (compensated) current transducer using the Hall effect
- Isolated plastic case recognized according to UL 94-V0.

Advantages

- Excellent accuracy
- Very good linearity
- Low temperature drift
- Optimized response time
- Wide frequency bandwidth
- No insertion losses
- High immunity to external interference
- Current overload capability.

Applications

- AC variable speed drives and servo motor drives
- Static converters for DC motor drives
- Battery supplied applications
- Uninterruptible Power Supplies (UPS)
- Switched Mode Power Supplies (SMPS)
- Power supplies for welding applications.

Application Domain

- Industrial.

Note: ¹⁾ With a di/dt of 100 A/ μs .

Current Transducer LT 1005-T

Isolation characteristics

V_d	Rms voltage for AC isolation test, 50 Hz, 1 min	6	kV
		Min	
dCp	Creepage distance	51.8	mm
dCI	Clearance distance	44.1	mm
CTI	Comparative Tracking Index (group III a)	225	

Applications examples

According to **EN 50178** and **IEC 61010-1** standards and following conditions:

- Over voltage category OV 3
- Pollution degree PD2
- Non-uniform field

	EN 50178	IEC 61010-1
dCp, dCI	Rated isolation voltage	Nominal voltage
Single isolation	5000 V	5000 V
Reinforced isolation	2500 V	2500 V

Safety



This transducer must be used in electric/electronic equipment with respect to applicable standards and safety requirements in accordance with the manufacturer's operating instructions.



Caution, risk of electrical shock

When operating the transducer, certain parts of the module can carry hazardous voltage (eg. primary busbar, power supply).

Ignoring this warning can lead to injury and/or cause serious damage.

This transducer is a build-in device, whose conducting parts must be inaccessible after installation.

A protective housing or additional shield could be used.

Main supply must be able to be disconnected.

Dimensions LT 1005-T (in mm.)

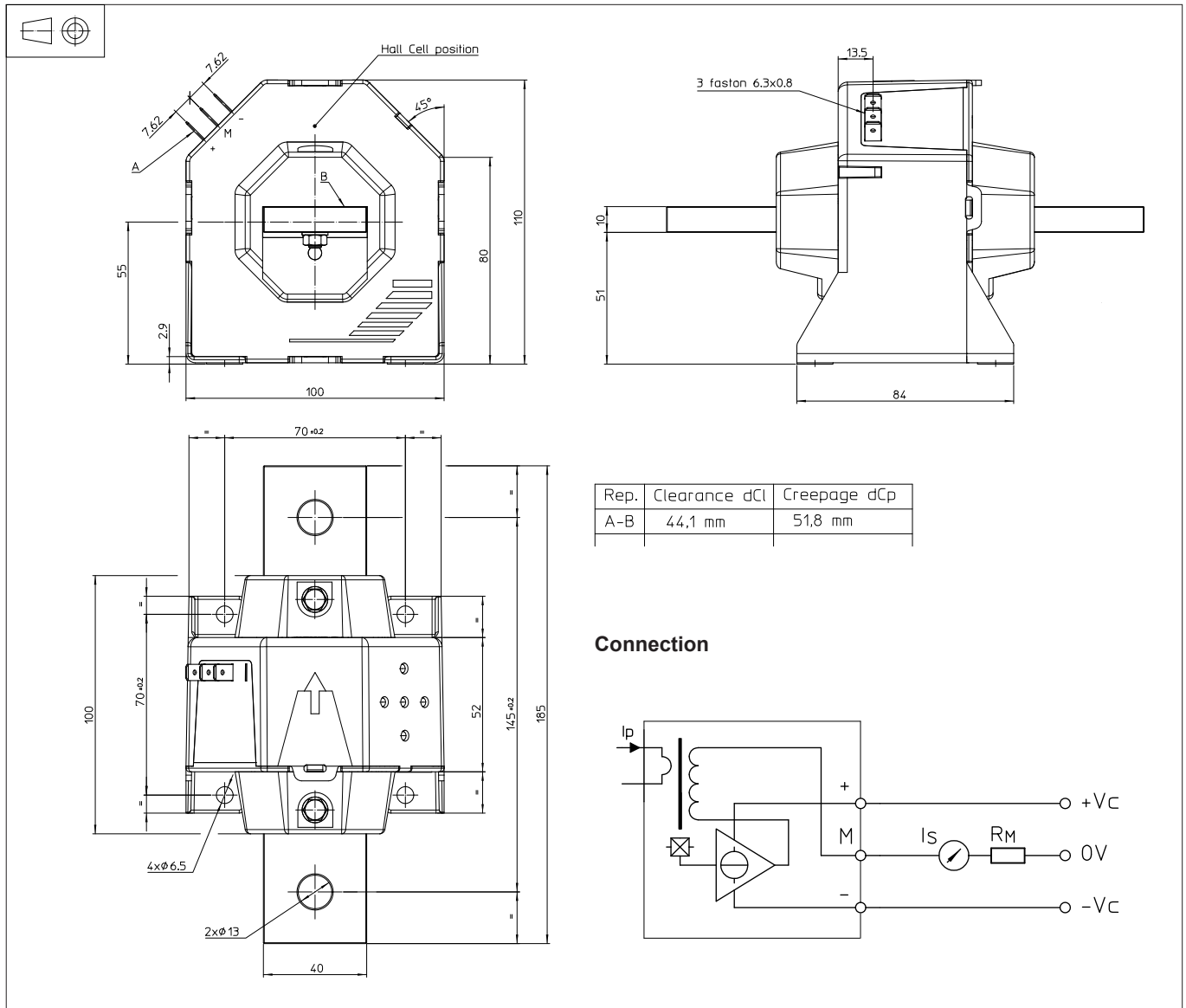

Mechanical characteristics

- General tolerance ± 0.5 mm
- Transducer fastening
 - 4 holes $\varnothing 6.5$ mm
 - 4 steel screws M6
 - Recommended fastening torque 4.20 Nm
 - Or by the primary bar
- Connection of primary
 - 2 holes $\varnothing 13$ mm
 - 2 steel screws M12
 - Recommended fastening torque 24.5 Nm
- Connection of secondary Faston 6.3 x 0.8 mm

Remarks

- I_S is positive when I_p flows in the direction of the arrow.
- Temperature of the primary conductor should not exceed 100°C.
- This is a standard model. For different versions (supply voltages, turns ratios, unidirectional measurements...), please contact us.