

ALUMINUM ELECTROLYTIC CAPACITORS

AK

Snap-in Terminal Type, 105°C Permissible Abnormal Voltage
series

- Withstanding 2000 hours application of rated ripple current at 105°C.
- Extended voltage range at 200V, 400V and 420V.
- Improved safety features for abnormally excessive voltage.
- Ideally suited for the equipment used at voltage fluctuating area.
- Compliant the RoHS directive (2011/65/EU).

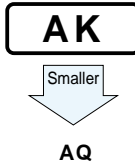

Specifications

Item	Performance Characteristics				
Category Temperature Range	- 25 to +105°C				
Rated Voltage Range	200 · 400 · 420V				
Rated Capacitance Range	33 to 1200μF				
Capacitance Tolerance	±20% at 120Hz, 20°C				
Leakage Current	$I \leq 3\sqrt{CV}$ (μA) (After 5 minutes' application of rated voltage) [C : Rated Capacitance (μF) V : Voltage (V)]				
Tangent of loss angle (tan δ)	0.20MAX. 120Hz at 20°C				
Stability at Low Temperature	Rated voltage(V)	200	400 · 420	Measurement frequency : 120Hz	
	Impedance ratio (MAX)	Z - 25°C/Z+20°C	8		8
Endurance	The specifications listed at right shall be met when the capacitors are restored to 20°C after D.C. bias plus rated ripple current is applied for 2000 hours at 105°C, the peak voltage shall not exceed the rated voltage.			Capacitance change	Within ±20% of the initial capacitance value
				tan δ	200% or less than the initial specified value
				Leakage current	Less than or equal to the initial specified value
Shelf Life	After storing the capacitors under no load at 105°C for 1000 hours and then performing voltage treatment based on JIS C 5101-4 clause 4.1 at 20°C, they shall meet the requirements listed at right.			Capacitance change	Within ±15% of the initial capacitance value
				tan δ	150% or less than the initial specified value
				Leakage current	Less than or equal to the initial specified value
Safety Performance	The pressure relief vent will operate in normal conditions, with no dangerous conditions such as flames, ignitions or dispersion of pieces of the capacitor and/or case.				
	rating		test conditions		
	Voltage (V)	Capacitance (μF)	Limited DC current	Test voltage	
	200	C < 330	4 A	300VDC and 375VDC	
		330 ≤ C < 470	5 A		
		470 ≤ C	7 A		
400	C < 100	2 A	500VDC and 600VDC		
	100 ≤ C < 220	4 A			
	220 ≤ C	7 A			
420	C < 100	2 A	520VDC and 630VDC		
	100 ≤ C < 220	4 A			
	220 ≤ C	7 A			
Marking	Printed with white color letter on black sleeve				

Drawing

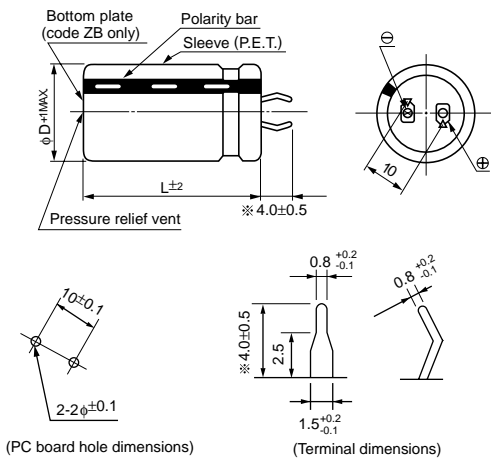

Type numbering system (Example : 200V 680μF)

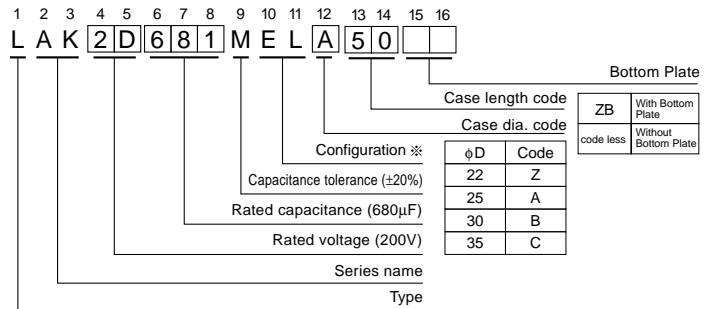

※ Please contact to us if other configurations are required.

Minimum order quantity : 50pcs.

● Dimension table in next page.

■Dimensions

200V (2D)				
Cap. (μF)	Size φD × L(mm)	Ripple (mA)	Leakage Current (mA)	Code
47	22 × 20	350	0.29	LAK2D470MELZ20
100	22 × 20	500	0.42	LAK2D101MELZ20
150	25 × 20	650	0.51	LAK2D151MELA20
180	22 × 25	700	0.56	LAK2D181MELZ25
	30 × 20	700	0.56	LAK2D181MELB20
220	22 × 25	740	0.62	LAK2D221MELZ25
270	22 × 30	900	0.69	LAK2D271MELZ30
	25 × 25	850	0.69	LAK2D271MELA25
	35 × 20	1100	0.69	LAK2D271MELC20
330	22 × 30	1050	0.77	LAK2D331MELZ30
	25 × 30	1050	0.77	LAK2D331MELA30
	30 × 25	1050	0.77	LAK2D331MELB25
390	22 × 35	1200	0.83	LAK2D391MELZ35
	25 × 30	1200	0.83	LAK2D391MELA30
	30 × 25	1200	0.83	LAK2D391MELB25
470	22 × 40	1300	0.91	LAK2D471MELZ40
	25 × 35	1300	0.91	LAK2D471MELA35
	30 × 25	1350	0.91	LAK2D471MELB25
560	22 × 45	1500	1.00	LAK2D561MELZ45
	25 × 40	1500	1.00	LAK2D561MELA40
	30 × 35	1550	1.00	LAK2D561MELB35
	35 × 25	1550	1.00	LAK2D561MELC25
680	25 × 50	1700	1.10	LAK2D681MELA50
	30 × 40	1700	1.10	LAK2D681MELB40
	35 × 30	1700	1.10	LAK2D681MELC30
820	30 × 45	1990	1.21	LAK2D821MELB45
	35 × 35	1990	1.21	LAK2D821MELC35
1000	30 × 50	2100	1.34	LAK2D102MELB50
	35 × 40	2100	1.34	LAK2D102MELC40
1200	35 × 50	2300	1.46	LAK2D122MELC50

420V (W6)				
Cap. (μF)	Size φD × L(mm)	Ripple (mA)	Leakage Current (mA)	Code
333	22 × 25	250	0.35	LAKW6330MELZ25
47	22 × 25	350	0.42	LAKW6470MELZ25
56	22 × 25	380	0.46	LAKW6560MELZ25
68	22 × 30	450	0.50	LAKW6680MELZ30
	25 × 25	450	0.50	LAKW6680MELA25
82	22 × 35	640	0.55	LAKW6820MELZ35
	25 × 30	640	0.55	LAKW6820MELA30
100	22 × 40	690	0.61	LAKW6101MELZ40
	25 × 30	690	0.61	LAKW6101MELA30
	30 × 25	690	0.61	LAKW6101MELB25
120	22 × 45	750	0.67	LAKW6121MELZ45
	25 × 35	750	0.67	LAKW6121MELA35
	30 × 30	750	0.67	LAKW6121MELB30
	35 × 25	750	0.67	LAKW6121MELC25
150	25 × 40	820	0.75	LAKW6151MELA40
	30 × 30	820	0.75	LAKW6151MELB30
	35 × 25	820	0.75	LAKW6151MELC25
180	25 × 45	900	0.82	LAKW6181MELA45
	30 × 35	900	0.82	LAKW6181MELB35
	35 × 30	900	0.82	LAKW6181MELC30
220	30 × 40	1000	0.91	LAKW6221MELB40
	35 × 35	1000	0.91	LAKW6221MELC35
270	30 × 45	1100	1.01	LAKW6271MELB45
	35 × 40	1100	1.01	LAKW6271MELC40
330	35 × 45	1200	1.11	LAKW6331MELC45

Rated ripple current (mArms) at 105°C 120Hz

400V (2G)				
Cap. (μF)	Size φD × L(mm)	Ripple (mA)	Leakage Current (mA)	Code
33	22 × 20	220	0.34	LAK2G330MELZ20
39	22 × 20	300	0.37	LAK2G390MELZ20
47	22 × 25	350	0.41	LAK2G470MELZ25
	25 × 20	350	0.41	LAK2G470MELA20
	30 × 20	400	0.41	LAK2G470MELB20
56	22 × 25	380	0.44	LAK2G560MELZ25
	25 × 20	380	0.44	LAK2G560MELA20
68	22 × 25	400	0.49	LAK2G680MELZ25
	25 × 25	450	0.49	LAK2G680MELA25
	30 × 20	500	0.49	LAK2G680MELB20
82	22 × 30	500	0.54	LAK2G820MELZ30
	25 × 25	500	0.54	LAK2G820MELA25
	30 × 20	500	0.54	LAK2G820MELB20
100	22 × 35	550	0.60	LAK2G101MELZ35
	25 × 30	530	0.60	LAK2G101MELA30
	30 × 25	530	0.60	LAK2G101MELB25
	35 × 20	550	0.60	LAK2G101MELC20
120	22 × 40	600	0.65	LAK2G121MELZ40
	25 × 30	600	0.65	LAK2G121MELA30
	30 × 25	600	0.65	LAK2G121MELB25
150	22 × 45	700	0.73	LAK2G151MELZ45
	25 × 35	700	0.73	LAK2G151MELA35
	30 × 30	700	0.73	LAK2G151MELB30
	35 × 25	700	0.73	LAK2G151MELC25
180	22 × 50	800	0.80	LAK2G181MELZ50
	25 × 40	800	0.80	LAK2G181MELA40
	30 × 30	800	0.80	LAK2G181MELB30
	35 × 25	800	0.80	LAK2G181MELC25
220	25 × 45	900	0.88	LAK2G221MELA45
	30 × 35	900	0.88	LAK2G221MELB35
	35 × 30	900	0.88	LAK2G221MELC30
270	30 × 40	980	0.98	LAK2G271MELB40
	35 × 35	960	0.98	LAK2G271MELC35
330	30 × 50	1210	1.08	LAK2G331MELB50
	35 × 40	1210	1.08	LAK2G331MELC40
390	35 × 45	1320	1.18	LAK2G391MELC45
470	35 × 50	1450	1.30	LAK2G471MELC50

●Frequency coefficient of rated ripple current

Frequency (Hz)		50	60	120	1k	10k or more
Coefficient	200V	0.85	0.88	1.00	1.15	1.20
	400・420V	0.88	0.90	1.00	1.10	1.15