

VOLTAGE DETECTOR

This IC series is usable for the CPU system of all types and wired logic system as it has the function of detecting the power supply voltage at the time of initial resetting after switching the power supply on and after instantaneous break in power supply voltage there-by accurately resetting the system this particular series has especially been designed as the high resetting output type.

FEATURES

- Current Consumption is Low. $I_{CCL}=30\mu A$ Typ.
 $I_{CCH}=300\mu A$ Typ.
- Resetting Output Minimum Guarantee Voltage is Low 0.8V Typ.
- Hysteresis Voltage is Provided 50mV Typ.
- Reset Signal Generation Starting Voltages:
 KIA7419P/F 1.9V Typ. KIA7433P/F 3.3V Typ.
 KIA7421P/F 2.1V Typ. KIA7434P/F 3.4V Typ.
 KIA7423P/F 2.3V Typ. KIA7435P/F 3.5V Typ.
 KIA7425P/F 2.5V Typ. KIA7436P/F 3.6V Typ.
 KIA7427P/F 2.7V Typ. KIA7439P/F 3.9V Typ.
 KIA7429P/F 2.9V Typ. KIA7442P/F 4.2V Typ.
 KIA7431P/F 3.1V Typ. KIA7445P/F 4.5V Typ.
 KIA7432P/F 3.2V Typ.
- Taping Type is also Available.

APPLICATIONS

- (1) As Control Circuit of Battery-Backed Memory Units.
- (2) As Measure Against Erroneous Operations at Power Supply ON-OFF Time.
- (3) As Measure Against System Runaway at Instantaneous Break of Power Supply etc.
- (4) As Resetting Function for the CPU-Mounted Equipment, such as Personal Computers, Printers, VTRs and so forth.

EQUIVALENT CIRCUIT

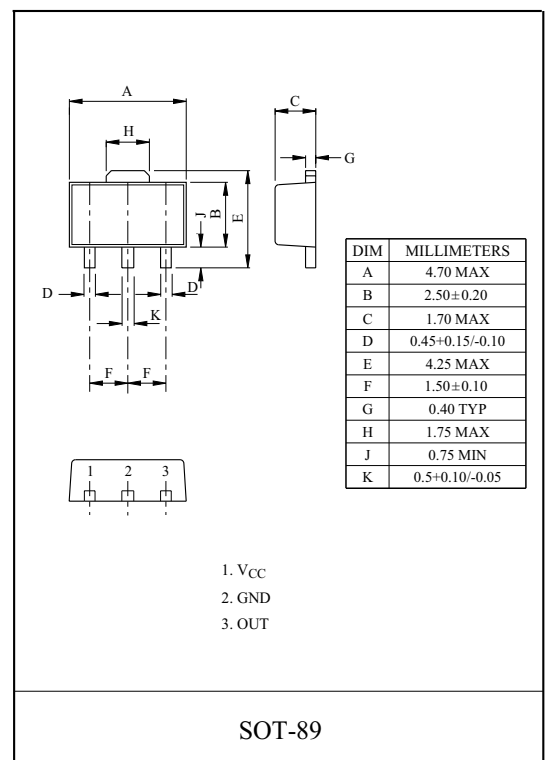
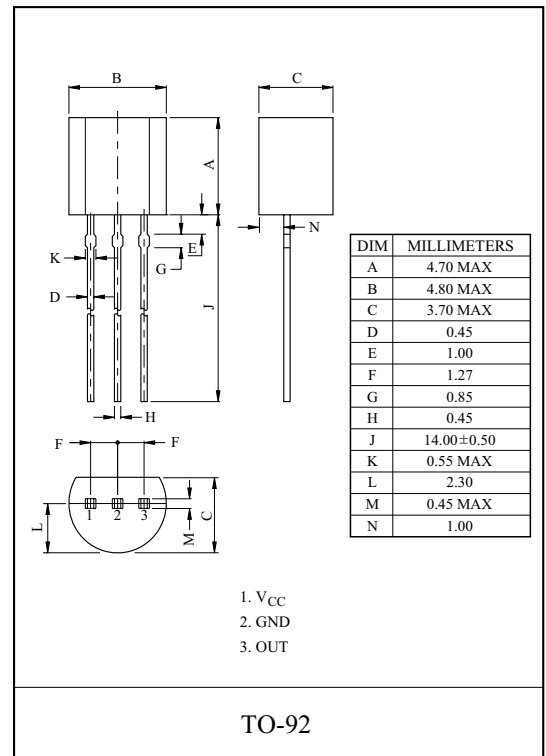
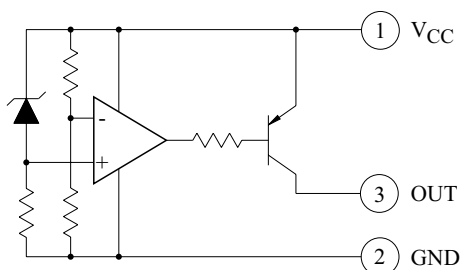

KIA7419P/F~KIA7445P/F

MAXIMUM RATINGS (Ta=25 °C)

CHARACTERISTIC		SYMBOL	RATING	UNIT
Supply Voltage		V _{CC}	-0.3~+7.5	V
Power Dissipation (Package Limitation)	KIA7419P~45P	P _D	400	mW
	KIA7419P~45F		500	
Operating Temperature		T _{opr}	-30~+75	°C
Storage Temperature		T _{stg}	-55~150	°C

Marking

Type No.	Marking	Type No.	Marking
KIA7419F	4A	KIA7433F	4J
KIA7421F	4B	KIA7434F	4K
KIA7423F	4C	KIA7435F	4L
KIA7425F	4D	KIA7436F	4M
KIA7427F	4E	KIA7439F	4N
KIA7429F	4F	KIA7442F	4P
KIA7431F	4G	KIA7445F	4R
KIA7432F	4H		

ELECTRICAL CHARACTERISTICS

CHARACTERISTIC	SYMBOL	TEST CIR.	TEST CONDITION	MIN.	TYP.	MAX.	UNIT	
Detecting Voltage	V _S	1	R _L =4.7k Ω V _{OH} ≧ V _{OL} -0.4	KIA7419P/F	1.75	1.9	2.05	V
				KIA7421P/F	1.95	2.1	2.25	
				KIA7423P/F	2.15	2.3	2.45	
				KIA7425P/F	2.35	2.5	2.65	
				KIA7427P/F	2.55	2.7	2.85	
				KIA7429P/F	2.75	2.9	3.05	
				KIA7431P/F	2.95	3.1	3.25	
				KIA7432P/F	3.05	3.2	3.35	
				KIA7433P/F	3.15	3.3	3.45	
				KIA7434P/F	3.25	3.4	3.55	
				KIA7435P/F	3.35	3.5	3.65	
				KIA7436P/F	3.45	3.6	3.75	
				KIA7439P/F	3.70	3.9	4.10	
				KIA7442P/F	4.00	4.2	4.40	
KIA7445P/F	4.30	4.5	4.70					
Low-Level Output Voltage	V _{OL}	1	R _L =4.7k Ω	V _{CC} -0.4	-	-	V	
Output Leakage Current	I _{OL}	1	V _{CC} =7.5V	-	-	0.1	μA	
Hysteresis Voltage	V _S	1	R _L =4.7k Ω	KIA7419P/F	20	50	100	mV
				KIA7421P/F				
				KIA7423P/F				
					30	50	100	
Detecting Voltage Temperature Coefficient	V _S /ΔT	1	R _L =4.7k Ω	-	±0.01	-	%/°C	
Circuit Current at on Time	I _{ccH}	1	V _{CC} =V _{Smin} -0.05V	-	300	500	μA	
Circuit Current at off Time	I _{ccL}	1	V _{CC} =5.25V	KIA7419P/F	-	30	70	μA
				KIA7421P/F				
				KIA7423P/F				
					-	30	50	
Threshold Operating Voltage	V _{opr}	1	R _L =4.7k Ω, V _{OH} ≧ V _{CC} -0.4	-	0.8	-	V	
"L" Transmission DELAY Time	tpHL	2	R _L =4.7k Ω, C _L =100pF	-	10	-	μs	
"H" Transmission DELAY Time	tpLH	2	R _L =4.7k Ω, C _L =100pF	-	10	-	μs	
Output Current	I _{OH}	1	V _{CC} =V _{Smin} -0.05V, R _L =0 Ω, T _c =25 °C	-2.0	-5.0	-	mA	

KIA7419P/F~KIA7445P/F

TEST CIRCUIT 1.

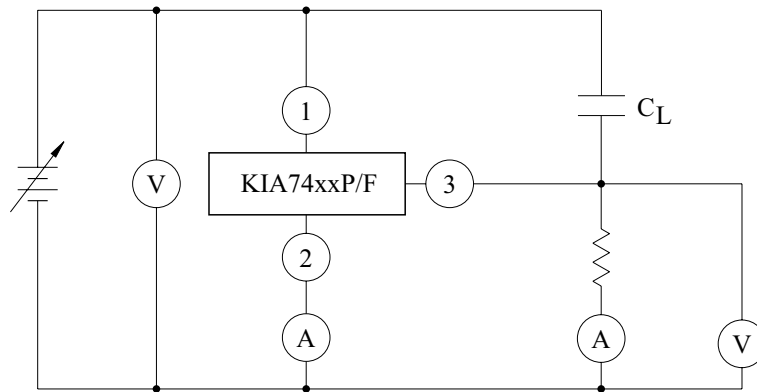

(A) is DC AMPERE METER

(V) is DC VOLT METER

TEST CIRCUIT 2.

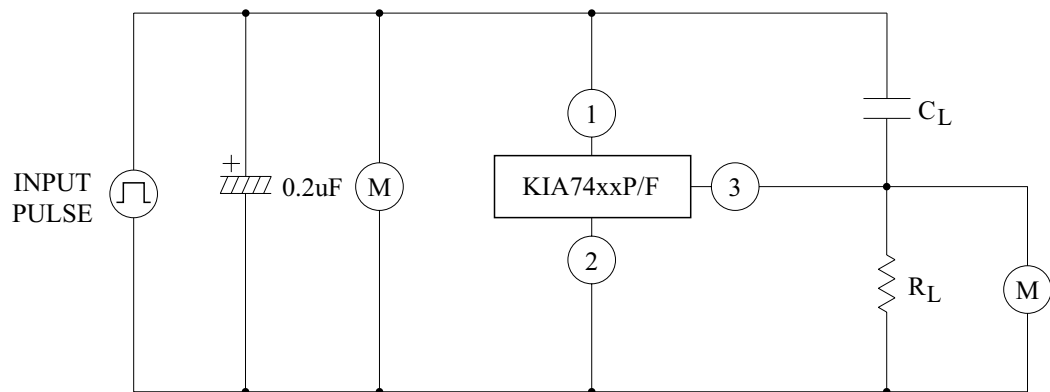

(M) is OSCILLOSCOPE MONITOR

PRECAUTION FOR USE

SOLDERING

Flat Package (SOT-89 Package)

Elements mounting styles of electronic devices are gaining in further diversification over recent years, and needs for components are all the more expanding in varieties. Especially, surface mounting is steadily penetrating into industrial segments as a world-wide popular technical trend. Although exposure to high temperature is inevitable during soldering we recommend limiting the soldering temperature to low levels as shown in figure for the sake of retaining inherent excellent reliability.

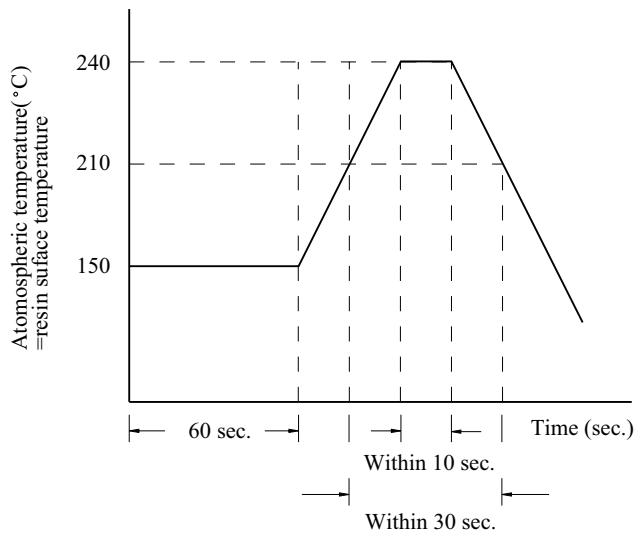

Fig 6

(a) When employing solder reflow method

- ① Atmospheric temperature around resin surfaces must be less than 240 °C, not exceeding the time length of 10 sec.
- ② Recommend temperature profile
- ③ Precautions on heating method

When resin is kept exposed to high temperature for a long time, device reliability may be marred.

Therefore, it is essential to complete soldering in the shortest time possible to prevent temperature of resin from rising.

(b) When employing halogen lamps or infrared-ray heaters

When halogen lamps or infrared-ray heaters are used, avoid direct irradiation onto resin surfaces ; such devices cause extensive localized temperature rise.

※ Please keep a reflow solder operating when SOT-89 package's soldering.