

CUSTOMER DRAWING

P/N: 3800S 75/-6

REV
D

PART NUMBER	MATERIAL	FINISH
3800S 75A-6	.025 THICK BRASS C26000, 1/2 HARD	PRETINNED
3800S 75AB-6	.025 THICK BRASS C26000, 1/2 HARD	NONE
3800S 75AD-6	.025 THICK BRASS C26000, 1/2 HARD	POST-TIN

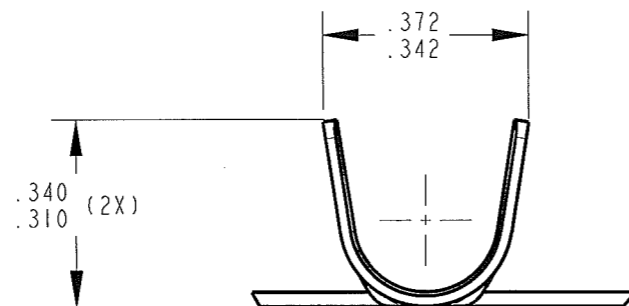
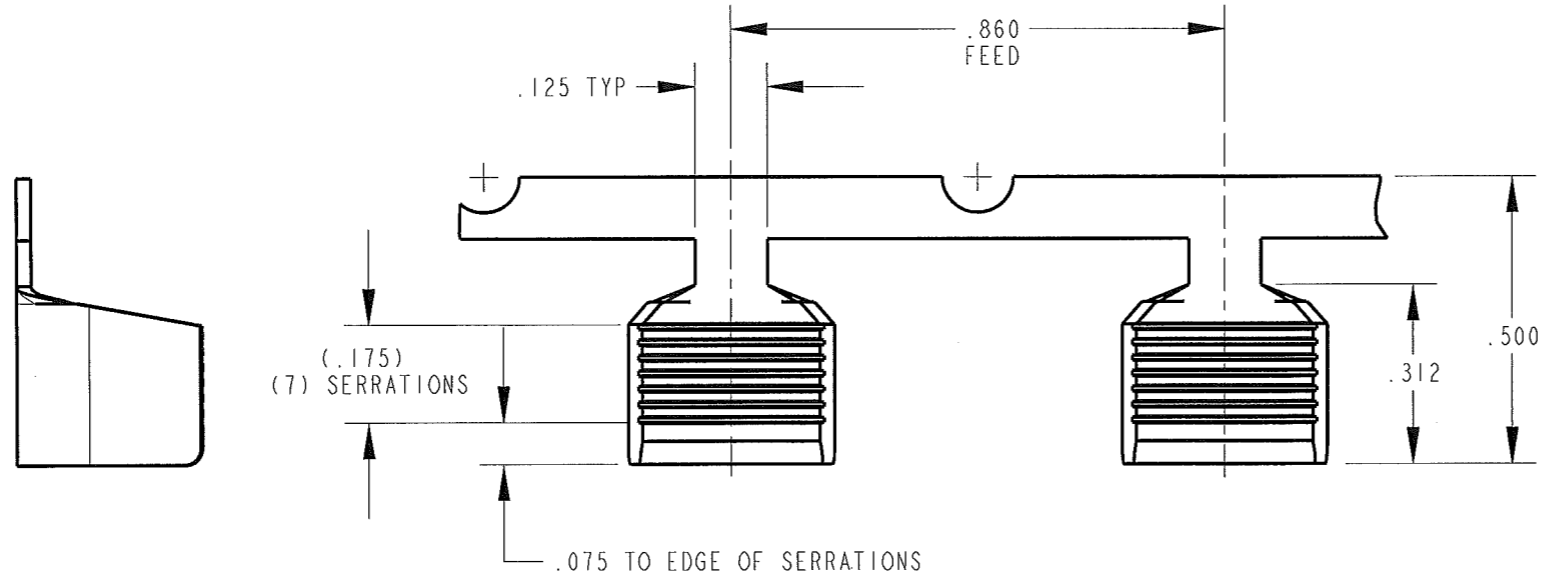
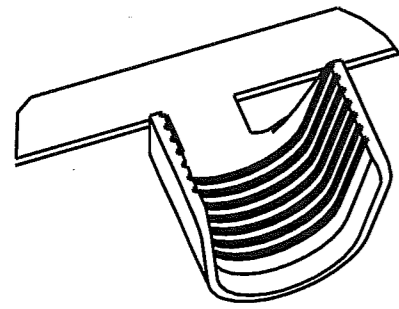

NOTES:

- CMA RANGE: 12000 TO 29000.
- FOR PIGTAIL SPLICES USED IN A BENCH APPLICATOR, ADD SUFFIX "PP" TO PART NUMBER (i.e. 3800S 75A-6PP), SEE FIGURE 1 FOR REELING.
- FOR THROUGH SPLICES USED IN A BENCH APPLICATOR, THE PART NUMBER REMAINS THE SAME AS IN THE TABLE (i.e. 3800S 75A-6). SEE FIGURE 2 FOR REELING.
- FOR PIGTAIL AND THROUGH SPLICES USED IN A SLIM-LINE AIR PRESS, THE PART NUMBER REMAINS THE SAME AS IN THE TABLE (i.e. 3800S 75A-6). SEE FIGURE 2 FOR REELING.
- PAPER INTERLEAVING ADDED TO REDUCE TANGLING IN REELS.
- RECOMMENDED WIRE COMBINATIONS:
 - (1) STRANDED WIRE
 - (2) MANGET WIRES
 - (3) MANGET WIRES UPON ARK-LES CONFIRMATION
- MANGET WIRES ARE TO BE PLACED IN SPLICE FIRST. STRANDED WIRES ARE TO BE PLACED ON TOP OF OR ADJACENT TO MANGET WIRE.
- REFER TO CRIMP HEIGHT FOR APPLICATION DATA.

ARK-LES
UNCONTROLLED

ARK-LES LETTERING
THIS SIDE.

ARK-LES LETTERING
THIS SIDE.

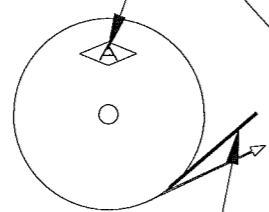
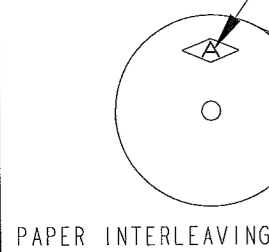

PAPER INTERLEAVING
FIGURE 1
(I.E. 3800S 75A-6PP)

PAPER INTERLEAVING
FIGURE 2
(I.E. 3800S 75A-6)

PRINT DIST.	PROD. REL. ECR 9458	2/23/93	CHK'D	TOLERANCES UNLESS OTHERWISE SPECIFIED	 CORPORATION STOUGHTON, MA
DEPT #	QUOTE REL.		DD 11/17/06	DECIMALS ± .010	
ENG X	DRAWN BY D.O'NEILL 11/01/06		APP.	METRIC ± 0.25mm	ORIGINAL IF RED PART NAME CUSTOMER DRAWING SPLICE TERMINAL
SALES	SUPERSEDES DWG. DATED: 9/13/1996		ET 11-17-06	ANGLES ± 1°	
STO X	SCALE 3:1		DO NOT SCALE PRINT		CAD#: 3800S_75-6-REVD_CUST P/N: 3800S 75/-6
RAL	MATERIAL: SEE TABLE				
JZ	REV/REDRWN ECR# S000127	11/01/06	DON	3RD ANGLE PROJECTION	REV D
CHINA	DESCRIPTION	DATE	DR.	DWG SIZE B	