

CUSTOMER DRAWING

P/N: 3800S 28A/ REV
AG

(AF) PART NO.	MATERIAL	FINISH
3800S 28A	.016 ± .0005 THICK BRASS C26000; 3/4 HARD	PRETINNED
3800S 28AB		NONE

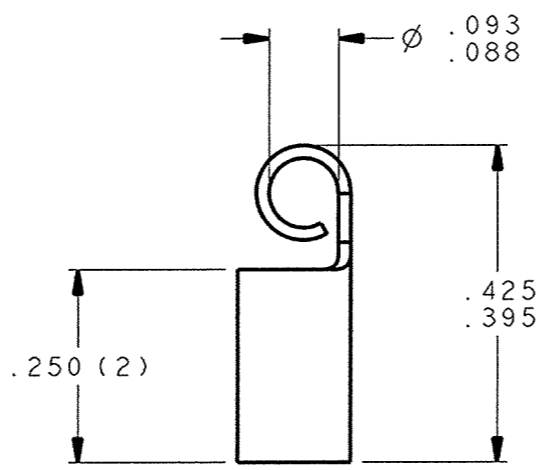
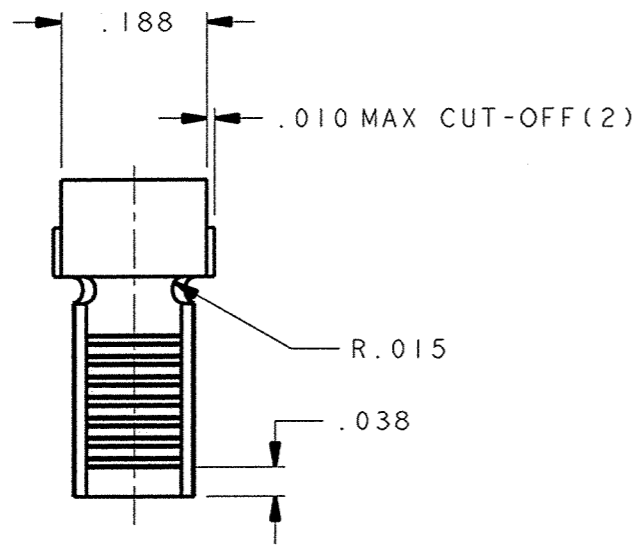

- (AF) NOTES:
- TO ACCOMMODATE (1) #16 - #20 AWG SOLID WIRE IN COMBINATION WITH (1) #17 - #26 MAGNET WIRE.
 - ALL CORNERS SHOWN SHARP MAY HAVE A .010 MAX. RADIUS.
 - FOR STANDARD REELING SEE FIGURE 1.
 - FOR REVERSE REELING ADD SUFFIX "R" TO PART NUMBER (i.e. 3800S 28AR). SEE FIGURE 2.
 - TOOLING MUST NOT REDUCE BURRS IN THE BROACHED AREA.
 - .188 LONG BARREL MUST RETAIN A .093 DIA. PIN WHEN INSERTED FROM EITHER DIRECTION.

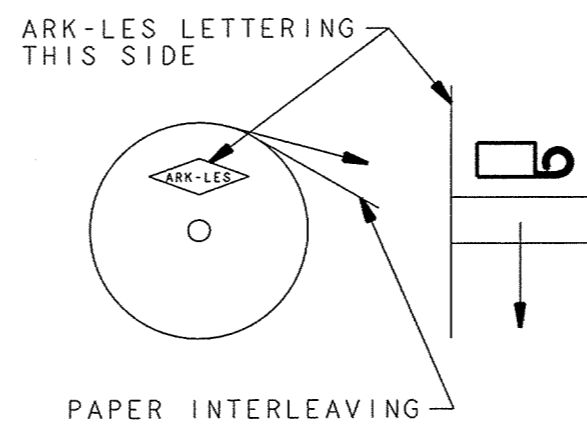
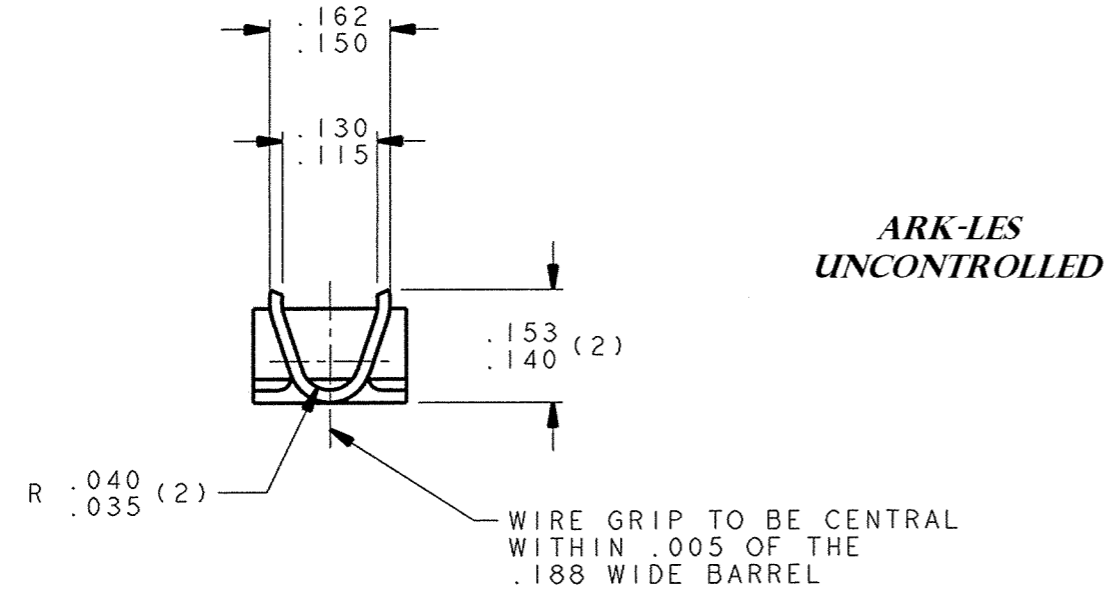

FIGURE 1
STANDARD REELING
(I.E. 3800S28A)

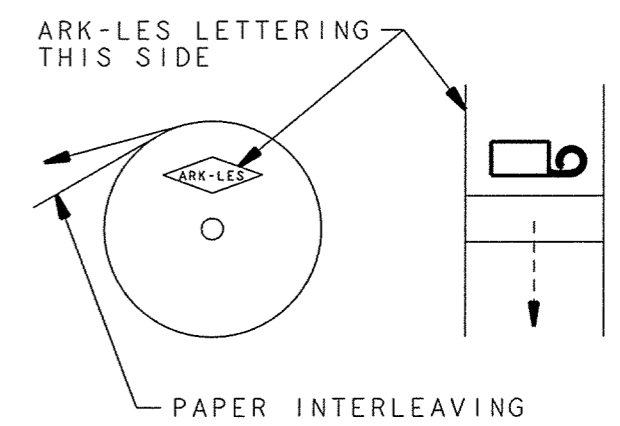
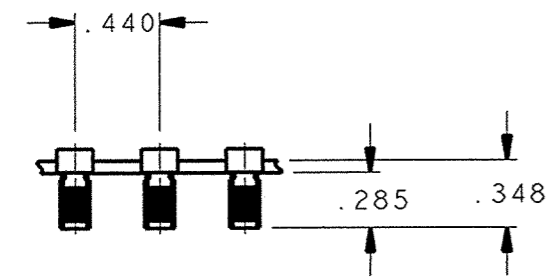

FIGURE 2
REVERSE REELING
(I.E. 3800S 28AR)



FABRICATED TERMINAL STRIP
SCALE 1=1

PRINT DIST.	PROD. REL. 79684 7/26/71 DW	CHK'D	TOLERANCES UNLESS OTHERWISE SPECIFIED	 STOUGHTON, MA ORIGINAL IF RED
DEPT #	QUOTE REL. 78973 5/24/71 JB	APP.	DRAWN BY BJ CARUTHERS 2/7/96	
ENG 1	SUPERSEDES DWG. DATED: 7/19/72		SCALE 4:1	PART NAME CUSTOMER DRAWING BARREL SPLICE
SALES			DO NOT SCALE PRINT	CAD#: 3800S_28A-REVAG_CUST
STO 1			MATERIAL: SEE TABLE	P/N: 3800S 28A/
RAL			FINISH: SEE TABLE	REV AG
JZ				
CHINA				