

CUSTOMER DRAWING

P/N: 3800S 121A
REV F

- NOTES:
1. RECOMMENDED STRIP LENGTH $1/8 \pm 1/32$.
 2. TO ACCEPT "18-"22 AWG WIRE.
 3. INSULATION RANGE .066 - .125 DIA
 4. INSERTION/ WITHDRAWAL TEST USING .049 DIA. STEEL TEST PIN WITH .050 X 10° LEAD-IN
 1ST. INSERTION: 5.0 LB. MAX.
 1.5 LB. MIN.
 6TH. WITHDRAWAL: 1.3 LB. MIN.

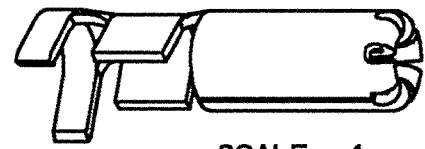

SCALE 4

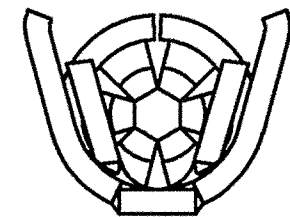
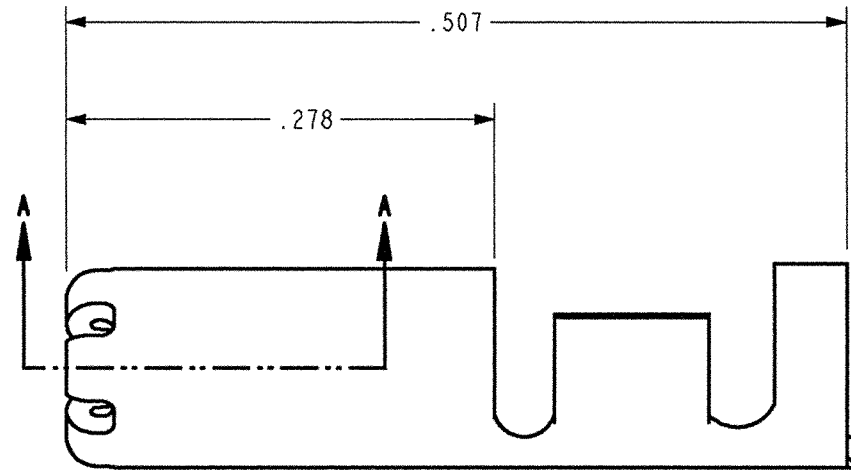
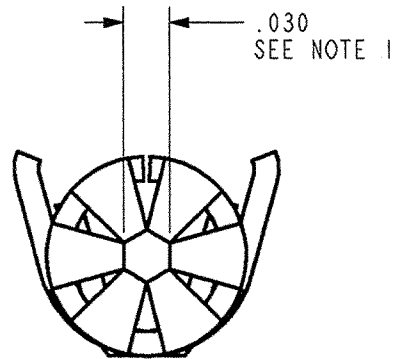

**ARK-LES
UNCONTROLLED**

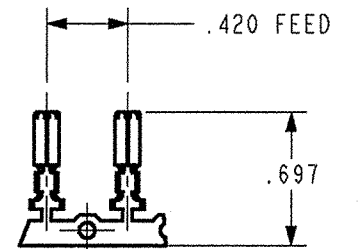
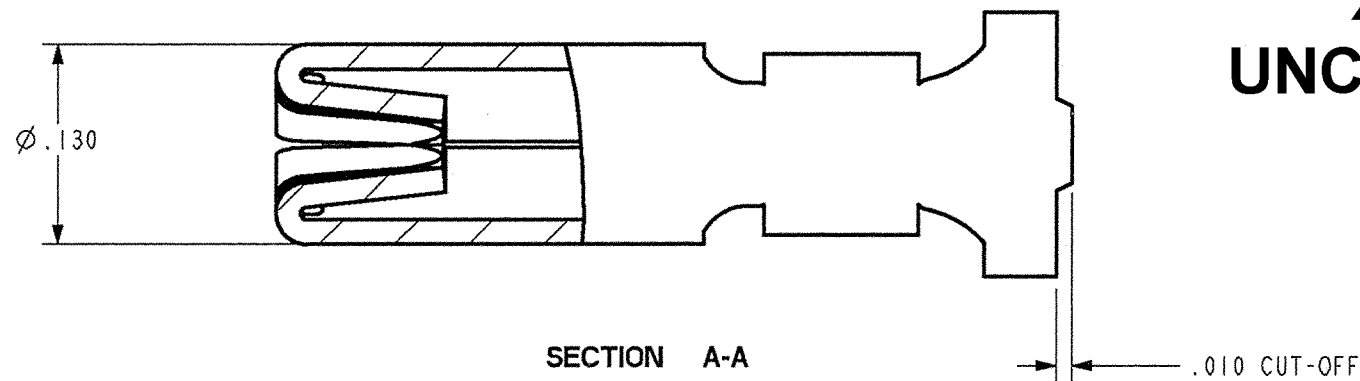

FABRICATED STRIP
SCALE 1

				PRINT DIST.	PROD. REL. DH2385 9-21-88	CHK'D	TOLERANCES UNLESS OTHERWISE SPECIFIED	Ark-Les CORPORATION STOUGHTON, MA
				DEPT #	QUOTE REL. JJB3108 3-11-88	RWT 8/27/01		
				ENG 1	DRAWN BY F. AHMAD 3-11-88		APP.	ORIGINAL IF RED
				SALES 2	SUPERSEDES DWG. DATED:		DECIMALS ± .010	
				STO	SCALE DO NOT SCALE PRINT		METRIC ± 0.25mm	PART SIX FINGER, NAME BARREL TERMINAL
				RAL	MATERIAL: .016 ± .001 BRASS		ANGLES ± 1°	
F	NEW DRAWING RELEASED	8-24-01	J.K.	JZ	FINISH: PRETINNED		3RD ANGLE PROJECTION	CAD#: 3800S121A
REV.	DESCRIPTION	DATE	DR.	CHINA				P/N: 3800S 121A