

Hermetically Sealed Miniature Ultra High Precision Z-Foil Technology Resistors with TCR of 0.05 ppm/°C, Tolerance of ± 0.001 % and Load Life Stability of ± 0.005 %, Unaffected by Humidity



INTRODUCTION

The Z-foil based oil filled, hermetically sealed VHP203 resistor represents an industry breakthrough. The hermetic sealing eliminates the ingress of moisture and oxygen, while the oil acts as a thermal conductor, thus eliminating long term degradation of elements of unsealed resistors, while at the same time allowing the device to accept short periods of overload without degradation.

The VHP203 is also available with laboratory and metrology level precision and long term stability with additional inhouse oriented process such as: special TCR plotting, chip stabilization inhouse thermal shock and bake prior to sealing, combined thermal shock and power conditioning on finished product, thermal and power conditioning, CLT.

The Z-foil technology provides a significant reduction of the resistive components sensitivity to ambient temperature variations (TCR) and applied power changes (PCR). When combined with the hermetic sealing and oil filling, the VHP203 resistor become **the most precise and stable resistor available**.

The value of the hermetic enclosure over the molded part is in long term performance.

With accuracy of ± 0.001 % (10 ppm) and a resistance range from 10 Ω to 150 kΩ and long term shelf life of less than 2 ppm, this device is virtually a secondary standard that can be carried in sets for daily or periodic calibration of factory measurement equipment.

TABLE 1 - TCR VS. RESISTANCE VALUE

RESISTANCE VALUE (Ω)	TYPICAL TCR AND MAX. SPREAD (- 55 °C to + 125 °C, + 25 °C ref.) (ppm/°C) ⁽¹⁾
100 to < 150K	± 0.2 ± 2
50 to < 100	± 0.2 ± 3
10 to < 50	± 0.2 ± 4

Note

(1) For lower TCR and for selected TCR tracking, please contact us

FEATURES

- Temperature coefficient of resistance (TCR): ± 0.05 ppm/°C (0 °C to 60 °C)
- Power coefficient “ΔR due to self heating”: 5 ppm at rated power
- Tolerance: to ± 0.001 % (10 ppm)
- Load life stability: ± 0.002 % maximum ΔR (60 °C for 2000 h at 0.1 W per chip)
- Electrostatic discharge (ESD) up to 25 000 V
- Resistance range: 10 Ω to 150 kΩ (higher or lower values of resistance available)
- Vishay Foil resistors are not restricted to standard values; specific “as required” values can be supplied at no extra cost or delivery (e.g. 1K2345 vs. 1K)
- Power rating: 0.3 W at + 25 °C
- Shelf life stability: **2 ppm for at least 6 years**
- Non-inductive, non-capacitive design
- Non hot spot design
- Rise time: 1 ns effectively no ringing
- Current noise: 0.010 μV_{RMS}/V of applied voltage (< - 40 dB)
- Thermal EMF: 0.05 μV/°C typical
- Voltage coefficient: < 0.1 ppm/V
- Non inductive: < 0.08 μH
- Terminal finish: lead (Pb)-free or tin/lead alloy
- Compliant to RoHS directive 2002/95/EC
- Impervious to harmful environments - oil filled
- For better performances, please contact us
- Prototype quantities available in just 5 working days or sooner. For more information, please contact foil@vishaypg.com



Available
RoHS*
COMPLIANT

APPLICATIONS

- Metrology
- Laboratory
- Industrial
- Measurement

FIGURE 1 - TRIMMING TO VALUES
(conceptual illustration)

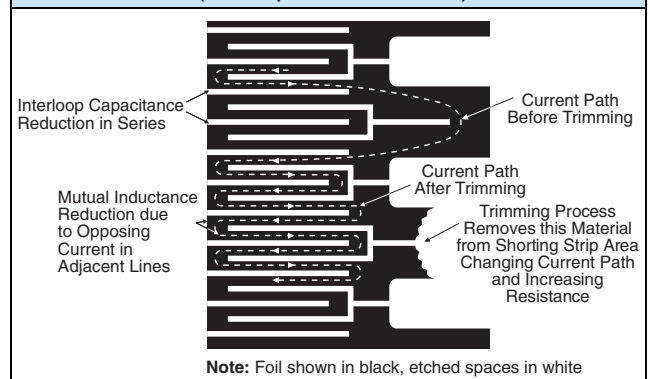

* Pb containing terminations are not RoHS compliant, exemptions may apply

TABLE 2 - MODEL SELECTION

MODEL NUMBER	RESISTANCE RANGE (Ω)	MAXIMUM WORKING VOLTAGE (1)	POWER RATING at + 25 °C	AVERAGE WEIGHT (g)	CONSTRUCTION BRIEF	DIMENSIONS	
						INCHES	mm
VHP203	10 to 66K 66K to 150K	300	0.2 W	1.4	Oil-filled, tinned copper leads, nickel shell, kovar and glass header	W: 0.162 ± 0.020	4.11 ± 0.51
VHP203J			0.3 W			L: 0.415 ± 0.020	10.54 ± 0.51
						H: 0.375 ± 0.020	9.52 ± 0.51
						LL: 1.000 ± 0.125	25.4 ± 3.18
						LS: 0.150 ± 0.010 (2)	3.81 ± 0.25
						ST: 0.095 max.	2.41 max.

Note

- See next page for numbered footnotes

TABLE 3 - STANDARD RESISTANCE TOLERANCE

TIGHTEST (Ω)	LOOSEST (%)
1K to 150K	± 0.001
500R to 1K	± 0.0025
50R to 500R	± 0.005
30R to 50R	± 0.01
20R to 30R	± 0.02
10R to 20R	± 0.05

FIGURE 2 - TYPICAL TCR CURVE Z-FOIL

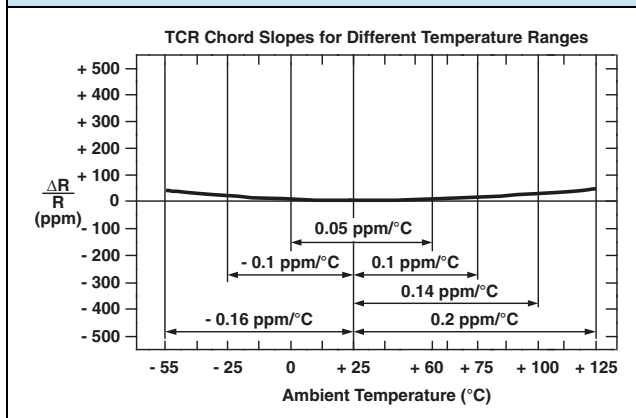

FIGURE 3 - POWER DERATING CURVE

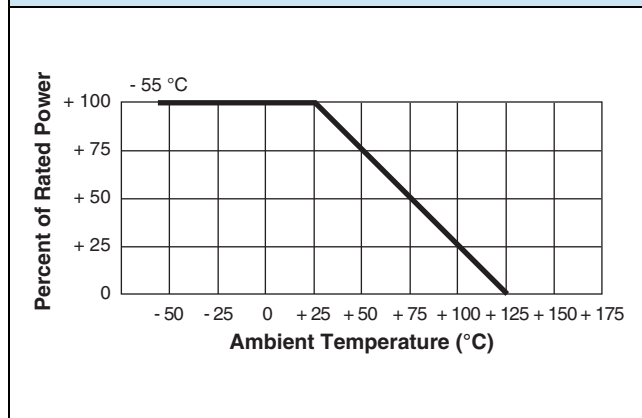

FIGURE 4 - STANDARD IMPRINTING AND DIMENSIONS

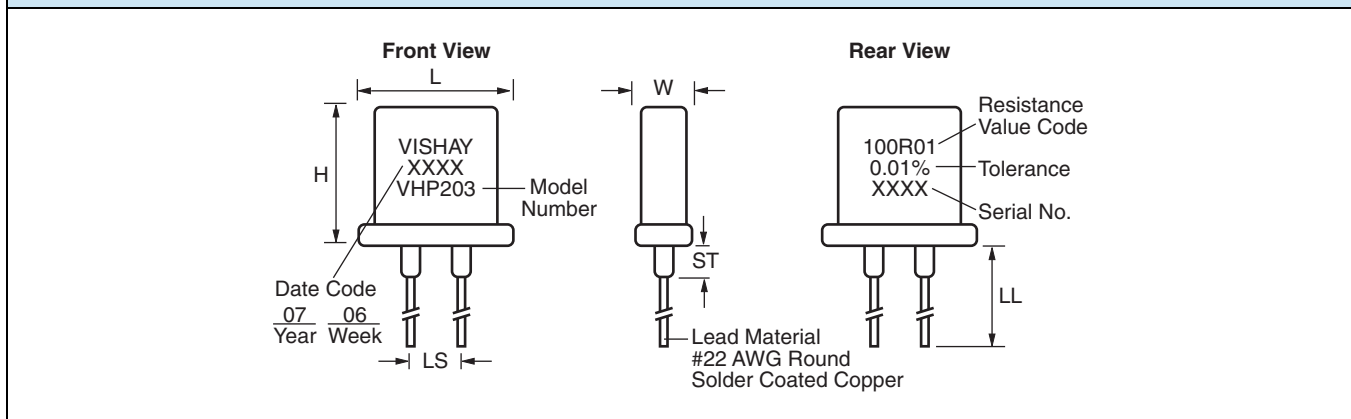

TABLE 4 - "H" SERIES SPECIFICATIONS

Stability ⁽⁶⁾ Load life at 2000 h Shelf life	$\pm 0.002\%$ maximum ΔR at 0.1 W per chip and at + 60 °C ± 2 ppm (0.0002 %) after at least 6 years
Current Noise	< 0.010 μV (RMS)/V of applied voltage (- 40 dB)
High Frequency Operation Rise time Inductance (L) ⁽³⁾ Capacitance (C)	1.0 ns without ringing 0.1 μH maximum; 0.08 μH typical 1.0 pF maximum; 0.5 pF typical
Voltage Coefficient	< 0.1 ppm/V ⁴
Thermal EMF ⁽⁵⁾	0.1 $\mu V/^\circ C$ maximum; 0.05 $\mu V/^\circ C$ typical; 1 $\mu V/W$ maximum
Hermeticity	10^{-7} atmospheric cc/s maximum

Notes

- (1) Not to exceed power rating of resistor
(2) 0.200" (5.08 mm) lead spacing available - specify VHP203J
(3) Inductance (L) due mainly to the leads
(4) The resolution limit of existing test equipment (within measurement capability of the equipment, or "essentially zero")
(5) $\mu V/^\circ C$ relates to EMF due to lead temperature difference and $\mu V/W$ due to power applied to the resistor
(6) Load life ΔR max. can be reduced through in-house oriented processes

TABLE 5 - ENVIRONMENTAL PERFORMANCE COMPARISON

	MIL-PRF-55182 CHAR J	VHP203 MAXIMUM ΔR	VHP203 TYPICAL ΔR
Test Group I Thermal shock, 5 x (- 55 °C to + 125 °C) Short time overload, 6.25 x rated power, 5 s	$\pm 0.2\%$ $\pm 0.2\%$	$\pm 0.01\%$ (100 ppm) $\pm 0.01\%$ (100 ppm)	$\pm 0.002\%$ (20 ppm) $\pm 0.003\%$ (30 ppm)
Test Group II Resistance temperature characteristics Characteristic Low temperature storage (24 h at - 65 °C) Low temperature operation (45 min, rated power at - 65 °C) Terminal strength	± 25 ppm/ $^\circ C$ $\pm 0.15\%$ $\pm 0.15\%$ $\pm 0.2\%$	table 1 $\pm 0.01\%$ (100 ppm) $\pm 0.01\%$ (100 ppm) $\pm 0.01\%$ (100 ppm)	± 0.05 ppm/ $^\circ C$ $\pm 0.002\%$ (20 ppm) $\pm 0.002\%$ (20 ppm) $\pm 0.002\%$ (20 ppm)
Test Group III DWV Resistance to solder heat, 20 s at + 260 °C Moisture resistance	$\pm 0.15\%$ $\pm 0.1\%$ $\pm 0.4\%$	$\pm 0.01\%$ (100 ppm) $\pm 0.01\%$ (100 ppm) $\pm 0.005\%$ (50 ppm)	$\pm 0.002\%$ (20 ppm) $\pm 0.005\%$ (50 ppm) $\pm 0.001\%$ (10 ppm)
Test Group IV Shock Vibration	$\pm 0.2\%$ $\pm 0.2\%$	$\pm 0.01\%$ (100 ppm) $\pm 0.01\%$ (100 ppm)	$\pm 0.002\%$ (20 ppm) $\pm 0.002\%$ (20 ppm)
Test Group V Life test at 0.3 W at + 25 °C 2000 h	$\pm 0.5\%$	$\pm 0.008\%$ (80 ppm)	$\pm 0.002\%$ (20 ppm)
Test Group Va Life test at 0.1 W at + 60 °C	$\pm 0.5\%$	$\pm 0.008\%$ (80 ppm)	$\pm 0.002\%$ (20 ppm)
Test Group VI High temperature exposure (2000 h at + 125 °C)	$\pm 2.0\%$	$\pm 0.02\%$ (200 ppm)	$\pm 0.005\%$ (50 ppm)
Test Group VII Voltage coefficient	5 ppm/V	< 0.1 ppm/V	< 0.1 ppm/V

TABLE 6 - GLOBAL PART NUMBER INFORMATION

NEW GLOBAL PART NUMBER: Y6072120K500V9L (preferred part number format)

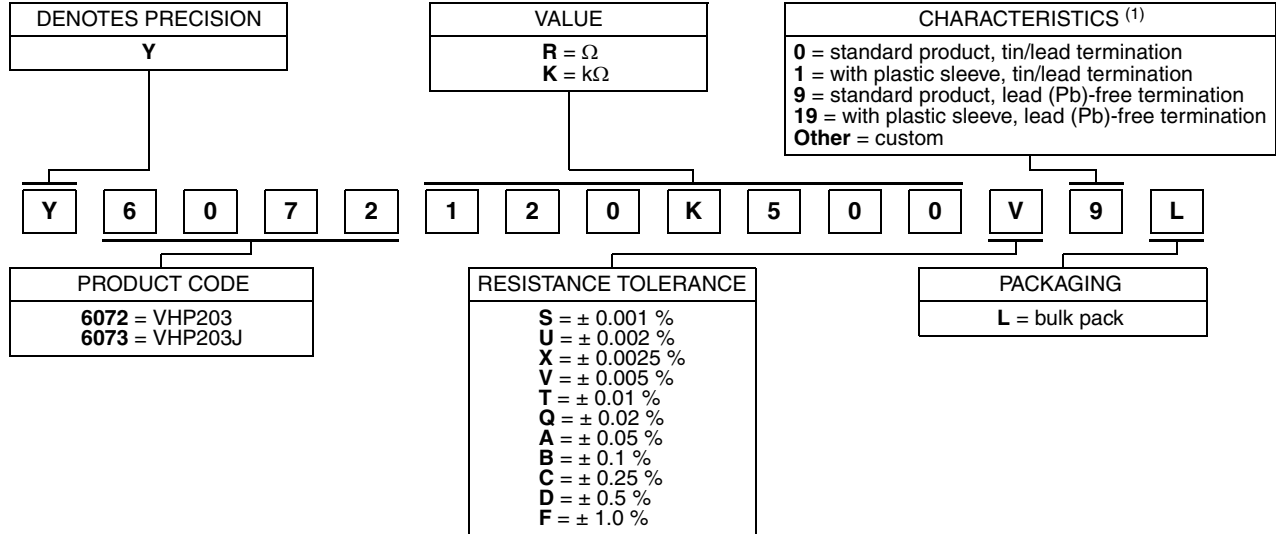

FOR EXAMPLE: ABOVE GLOBAL ORDER Y6072 120K500 V 9 L:

TYPE: VHP203
 VALUE: 120.5 kΩ
 ABSOLUTE TOLERANCE: ± 0.005 %
 TERMINATION: lead (Pb)-free
 PACKAGING: bulk pack

HISTORICAL PART NUMBER: VHP203T 120K50 V B (will continue to be used)

VHP203	T		120K50	V	B
MODEL	TERMINATION	PLASTIC SLEEVE	OHMIC VALUE	TOLERANCE	PACKAGING
VHP203 VHP203J	T = lead (Pb)-free None = tin/lead	P = plastic sleeve None = standard	120K50 = 120.5 kΩ	S = ± 0.001 % U = ± 0.002 % X = ± 0.0025 % V = ± 0.005 % T = ± 0.01 % Q = ± 0.02 % A = ± 0.05 % B = ± 0.1 % C = ± 0.25 % D = ± 0.5 % F = ± 1.0 %	B = bulk pack

Note

(1) For non-standard requests, please contact application engineering.

Disclaimer

ALL PRODUCTS, PRODUCT SPECIFICATIONS AND DATA ARE SUBJECT TO CHANGE WITHOUT NOTICE.

Vishay Precision Group, Inc., its affiliates, agents, and employees, and all persons acting on its or their behalf (collectively, "Vishay Precision Group"), disclaim any and all liability for any errors, inaccuracies or incompleteness contained herein or in any other disclosure relating to any product.

The product specifications do not expand or otherwise modify Vishay Precision Group's terms and conditions of purchase, including but not limited to, the warranty expressed therein.

Vishay Precision Group makes no warranty, representation or guarantee other than as set forth in the terms and conditions of purchase. **To the maximum extent permitted by applicable law, Vishay Precision Group disclaims (i) any and all liability arising out of the application or use of any product, (ii) any and all liability, including without limitation special, consequential or incidental damages, and (iii) any and all implied warranties, including warranties of fitness for particular purpose, non-infringement and merchantability.**

Information provided in datasheets and/or specifications may vary from actual results in different applications and performance may vary over time. Statements regarding the suitability of products for certain types of applications are based on Vishay Precision Group's knowledge of typical requirements that are often placed on Vishay Precision Group products. It is the customer's responsibility to validate that a particular product with the properties described in the product specification is suitable for use in a particular application.

No license, express, implied, or otherwise, to any intellectual property rights is granted by this document, or by any conduct of Vishay Precision Group.

The products shown herein are not designed for use in life-saving or life-sustaining applications unless otherwise expressly indicated. Customers using or selling Vishay Precision Group products not expressly indicated for use in such applications do so entirely at their own risk and agree to fully indemnify Vishay Precision Group for any damages arising or resulting from such use or sale. Please contact authorized Vishay Precision Group personnel to obtain written terms and conditions regarding products designed for such applications.

Product names and markings noted herein may be trademarks of their respective owners.