



Frequency Range:

3.01MHz to 100.00MHz

Features:

- High Reliability & Low Cost Unit
- Tight Stability & Extended Temperature Available
- Lead-free Type



Actual Size

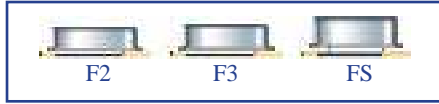

QUARTZ
CRYSTALS

■ Standard Specifications

Item	Value
Frequency Range	3.01 to 100.00 MHz
Frequency Tolerance	±30ppm (tighter tolerance also available)
Frequency Tolerance over Temperature range	±50ppm (tighter tolerance also available)
Operating Temperature Range	-10 °C to +60 °C (other operating range also available)
Operable Temperature Range	-40 °C to +85 °C
Equivalent Series Resistance (ESR)	Please refer to the ESR Table
Drive Level	50μW (0.001μW to 1000μW also available)
Load Capacitance	12pF (3pF, 4.5pF, 6pF and series also available)
Aging	±5ppm/year

■ ESR Table

Frequency Range (MHz)	Mode	Standard ESR (Ohm)
3.01 to 3.5	AT Cut Fund.	300
3.5 to 4.0	AT Cut Fund.	150
4.0 to 4.5	AT Cut Fund.	130
4.5 to 5.0	AT Cut Fund.	110
5.0 to 6.0	AT Cut Fund.	80
6.0 to 7.0	AT Cut Fund.	60
7.0 to 10.0	AT Cut Fund.	50
10.0 to 13.0	AT Cut Fund.	40
13.0 to 50.0	AT Cut Fund.	30
27.0 to 100.0	BT Cut	40
26.0 to 100.0	3rd Overtone	100

Note:

1. Manufacturer reserves the right to change the specification and content of this product for improvement without notification.
2. Custom specification is welcome. Please contact our sales representative for further details.
3. If the crystal is intended for applications which have direct impact on human life and properties, and require a high degree of reliability and safety concerns, customers must provide full information such as but not limit to the application, electrical and reliability specification at the inquiry beginning stage.

<http://www.hongkongcrystal.com>

E-mail: China: salescn1@hongkongcrystal.com

HongKong/Overseas: inquiry@hongkongcrystal.com

HongKong/Overseas: T:+852-35112388 F:+852-35112420

Shenzhen: T:+86-755-82540080 F:+86-755-82540036

Shanghai: T:+86-21-34250126 F:+86-21-34250126



■ Dimensions (mm) and Solder Pad Layout (mm)

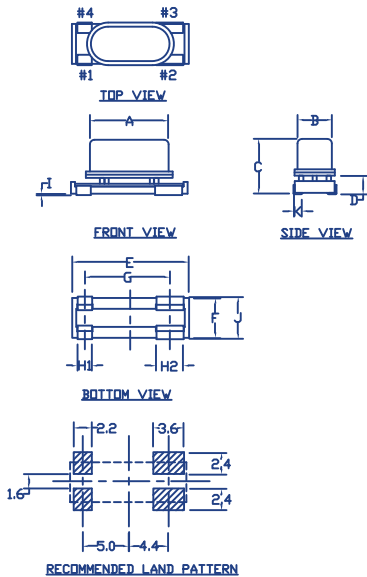

ITEM	DIMENSION	
A	10.16 Max.	
B	3.8 Max.	
C	XTAL TAPE	
	F2	4.1 Max.
	F3	4.5 Max.
	FS	5.5 Max.
D	1.9 Max.	
E	13.1 Max.	
F	4.6	
G	9.4	
H1	1.6	
H2	3.0	
I	0.2±0.1	
J	5.0 Max.	
K	1.0	

MARKING INFORMATION

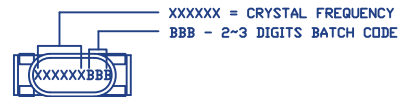

■ Tape & Reel (mm)

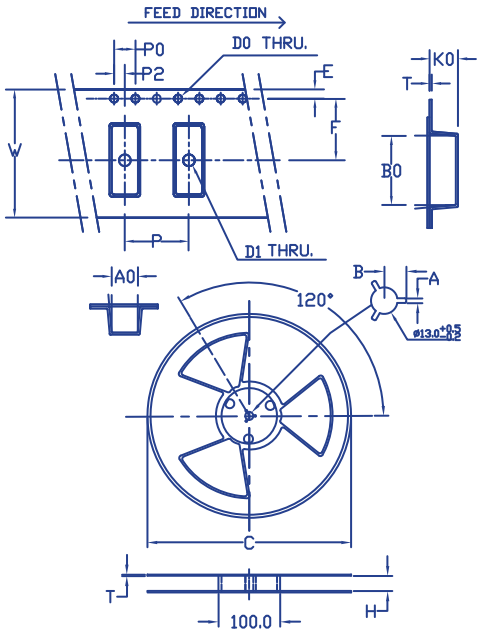

PART NO.	F2 F3	FS
	48060037	
W	24.0±0.3	24.0±0.3
P	12.0±0.1	12.0±0.1
P2	2.0±0.1	2.0±0.1
P0	4.0±0.1	4.0±0.1
A0	5.7±0.1	5.6±0.1
B0	13.4±0.1	13.4±0.1
E	1.75±0.1	1.75±0.1
F	11.5±0.1	11.5±0.1
D0	ø1.5±0.1	ø1.5±0.1
D1	ø1.5±0.1	ø1.5±0.1
T	0.35±0.05	0.40±0.05
K0	4.2±0.1	5.5±0.1
PART NO.	48060006	
	C1	ø330±1
	A	2.3±0.3
	B	10.75±0.2
	T	24.5±0.1
	H	2.3±0.3
QTY.	1000PCS/R	