

**Power Solid State Relay
With Analog Control, pitch 22.5mm
compact size and DIN rail mounting.**

SIM465000

**Phase angle controller
Output : 160-450VAC 40A(*)
Input : Analog 0-10V**



- ❑ Ready to use Single-Phase Relay:
Phase angle controller
Transfer characteristic : Angle open loop
Operating voltage : 160 to 450V
Operating Current : 0.1 to 40A
- ❑ Wide variety of applications.
- ❑ Main frequency range : 40 to 70 Hz with self adaptation
- ❑ Analog control : Voltage 0-10V
- ❑ Green LED visualization on the input
- ❑ Relay without trimmer (factory setting)
- ❑ Isolated internal power supply (taken from the mains)
- ❑ Built in protection : RC and VDR
- ❑ Mounting and dismounting on DIN rail without any tool or directly mountable on panel with screws.
- ❑ Designed in conformity with EN60947-4-3 (IEC947-4-3) and EN60950



(*) see conditions, thermal curve page 4.

Dimensions :

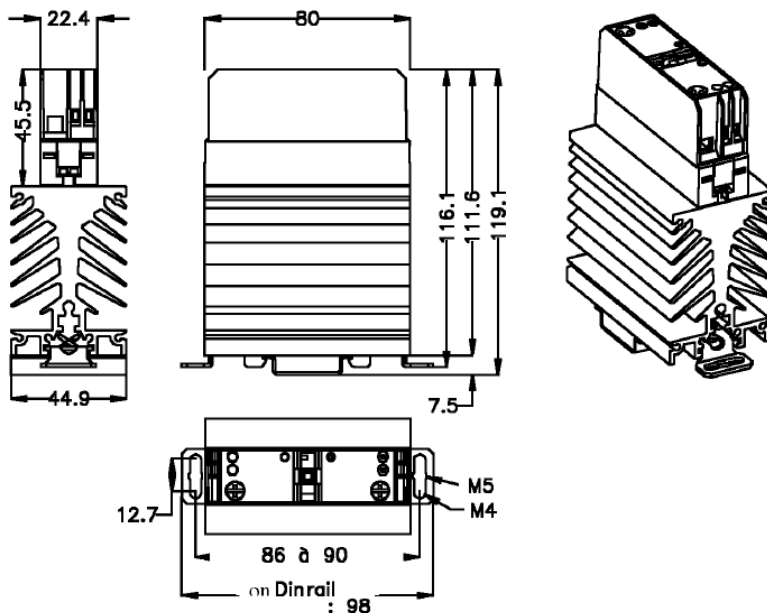

Typical application:

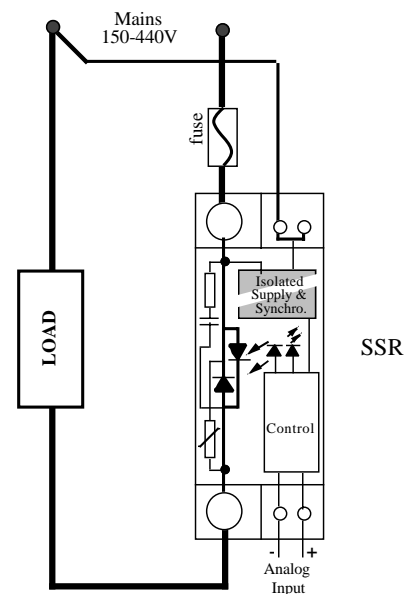

Proud to serve you

celduc®
r e l a i s

Control characteristics (at 25 °C)

Paramètre / Parameter	Conditions	Symbol	Typ.	Unit
Operating control voltage		Uc	0 to 10V	V
Maximum input voltage		Uc max	± 30V	V
Input resistor		Rc	20	kΩ
Input LED			green	
Rise and fall time	see fig. 2	time	62	ms
Input immunity	IEC 1000-4-4 (burst)		2kV	
Input immunity	IEC 1000-4-5(schocks)		2KV	

Output characteristics (at 25 °C)

Parameter	Conditions	Symbol	Typ.	Unit
Load voltage		Ue	400	V rms
Operating range		Uemin-max	160-450	V rms
Peak voltage		Up	1200	V
Mains frequency range		fm	40-70	Hz
Clamping voltage		Uclamp	820 (@1mA)	V
internal power supply current consumption (from mains)	@Ue, 50Hz	Ie	6	mA rms
AC-51 nominal current : permanent	(see Fig. 4 page 4)	Ie AC-51	40	A rms
AC-53 nominal current		Ie AC-53	12	A rms
Non repetitive overload current	tp=10ms (Fig. 3)	I _{tsm}	550	A
On state voltage drop (typical value)	@ 25°C	Vt	0,9	V
Dynamic resistance (typical value)		rt	8	mΩ
Output Power dissipation (typical value for full conduction)		Pd	0,81xIe+0,08xIe ²	W
Thermal resistance between junction to air		Rthj/a	3,3 (2,5)	K/W
Off state leakage current	@Ue, 50Hz	I _{lk}	<5	mA
Minimum load current		I _{emin}	100	mA
Rise and fall time	@50Hz see fig. 2	tau	15	ms
Delay time	@50Hz see fig. 2	td max	20	ms
Power up initialisation time	@Ue, 50Hz	t init.	160	ms
Off state dv/dt		dv/dt	500	V/μs
Maximum non repetitive di/dt		di/dt	50	A/μs
I _{2t} (<10ms)		I ² _t	1500	A ² s
Conducted immunity level	IEC 1000-4-4 (burst)		4kV criterion B	
Conducted immunity level	IEC 1000-4-5(schocks)		4kV criterion B	
Short circuit protection	FERRAZ		gRC 25A/32A/50A/63A 14x51	

General characteristics (at 25 °C)

Input to output insulation voltage	Ui	4000	VRMS
Output to status insulation voltage	Ui	2500	VRMS
Output to case insulation voltage	Ui	4000	VRMS
Insulation resistance	Ri	100 (@500VDC)	MΩ
Rated impulse voltage	U _{imp}	4000	V
Protection level / IEC 529	-	IP20	
Pollution degree	-	2	
Vibration resistance 10 -55 Hz according to CEI68 :	double amplitude	(not tested)	
Shocks resistance according to CEI68 (on DIN rail / with screws)	-	30/50	g
Ambient temperature (with no icing or condensation)	-	-20 /+70	°C
Storage temperature (with no icing or condensation)	-	-40/+100	°C
Ambient humidity	HR	40 to 85	%
Weight		270	g
Conformity		EN60947-4-3 (IEC60947-4-3)	



ISO 9001
N° 1993/1106a

celduc®
r e l a i s

www.celduc.com

Rue Ampère B.P. 4 42290 SORBIERS - FRANCE E-Mail : celduc-relais@celduc.com
 Fax +33 (0) 4 77 53 85 51 Service Commercial France Tél. : +33 (0) 4 77 53 90 20
 Sales Dept.For Europe Tel. : +33 (0) 4 77 53 90 21 Sales Dept. Asia : Tél. +33 (0) 4 77 53 90 19

Transfer characteristics (at 25°C)

Paramètre / Parameter	Conditions	Symbol	Min	Nom	Max	Unit
Operating analog voltage	Us			0-10		V
Minimum release voltage			0,1			V
Uload/Ue (@ Ue typ.)	@ Uc=10V			>98		%
Transfer accuracy				2		%
Transfer type		angle linear (see Fig. 1)				

Fig. 2 : Timing (Switch ON) @50Hz

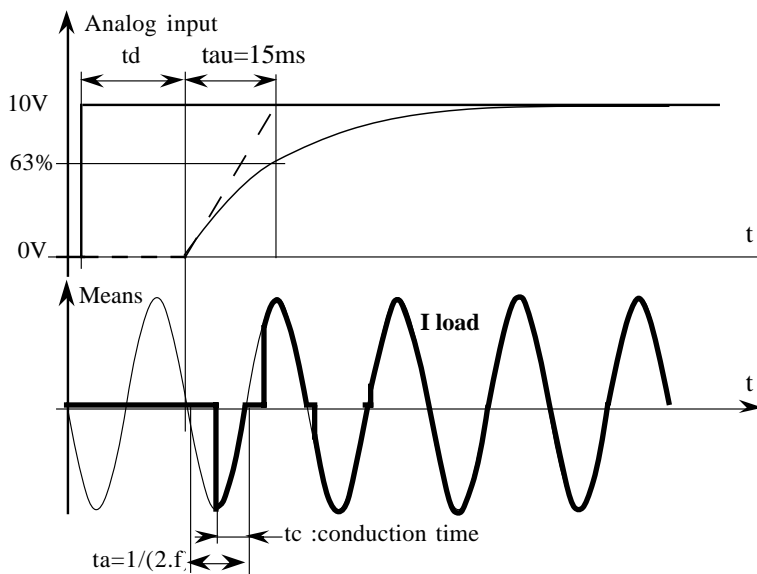
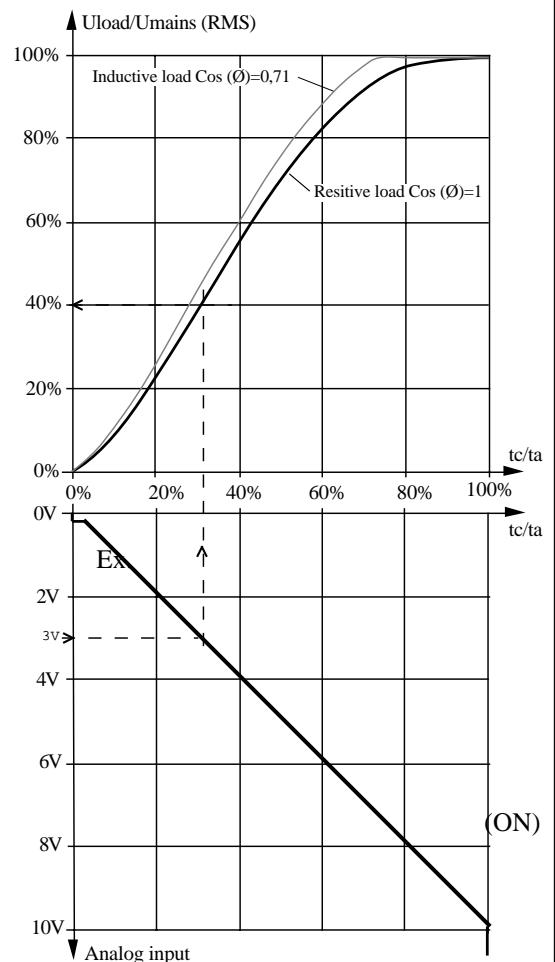

Fig.1 Transfer characteristic :



Ex. with resistive load :
Analog input=3V =>Uload/U mains=40%

Other possibilities with SIL4 series :(consult us)

- With trimmer for minimum step level setting:
- With trimmer for fall and rise time setting:
- Type of soft fall and rise time :linear or exponential
- Transfer characteristic: angle, RMS, power
- Analog input :0 - 5V, 4 - 20mA, ...
- Mains frequency range
- Mains voltage range
- Operating current



ISO 9001
N° 1993/1106a

celduc®
r e l a i s

www.celduc.com

Rue Ampère B.P. 4 42290 SORBIERS - FRANCE E-Mail : celduc-relais@celduc.com
 Fax +33 (0) 4 77 53 85 51 Service Commercial France Tél. : +33 (0) 4 77 53 90 20
 Sales Dept.For Europe Tel. : +33 (0) 4 77 53 90 21 Sales Dept. Asia : Tél. +33 (0) 4 77 53 90 19

Thermal specifications.

♦ **The curve "1"** gives the limits of the product. The temperature reached are acceptable for the components. These values are in compliance with most of SSRs manufacturers. In a cabinet with a minimum of ventilation or a non permanent current, these values are correct.

♦ **The curve "2"** gives the limits of the product according to EN60947-4-3 with a maximum rise temperature of 50°C (@40°C) for a permanent working and in air calm (test during 8 hours).

♦ For a non permanent current, you can calculate the average power = Pd x duty cycle and check the rise temperature : $\Delta Tj = Pd \times Rthj/a$ (Pd and Rthj/a are given page 2)). The junction temperature must not exceed 125°C at the maximum ambient temperature. **The maximum current is limited to the size of the thyristors = 50A.**

♦ The thermal constant (Cth) of the product is 7 minutes. That means the rise temperature is only 63% of the stabilized temperature after a running time of 7 minutes.

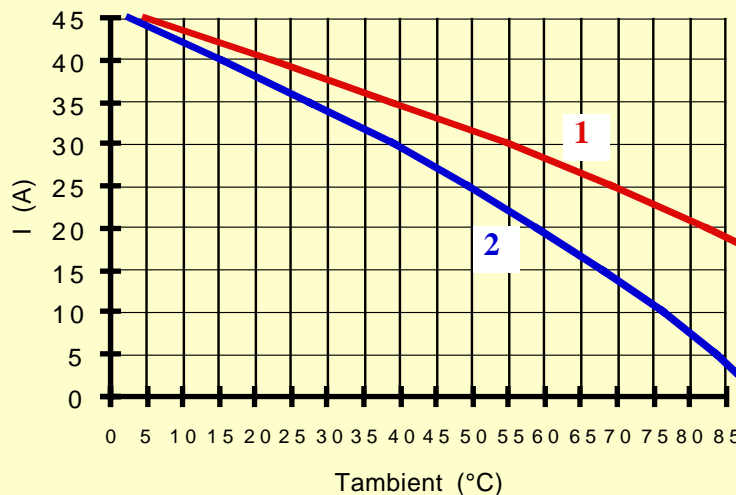

fig. 4

Overload current.

1 - **No repetitive I_{tsm}** is given without voltage reapplied. This curve is used for the determination of the protection.

2 - **Repetitive I_{tsm}** is given for inrush current with initial T_j = 70°C. In normal working, this curve mustn't be exceeded. Be careful, the repetition of the surge current decrease the lifetime SSR's.

fig 3

Fig.3 Surge current : I_{tsm} (Apeak) = f(t) for 50A models with I_{tsm} =550A

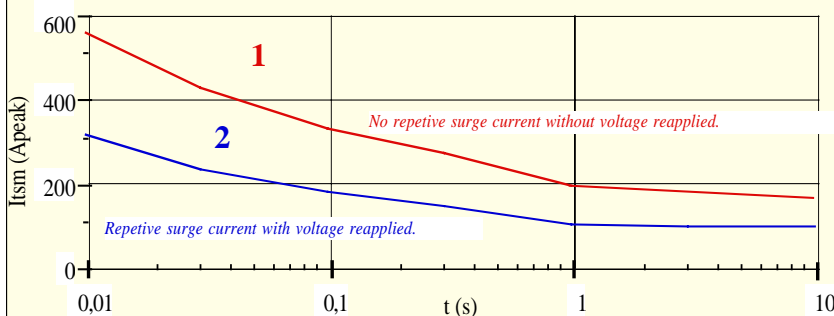

Mounting and dismounting on DIN rail without any tool.

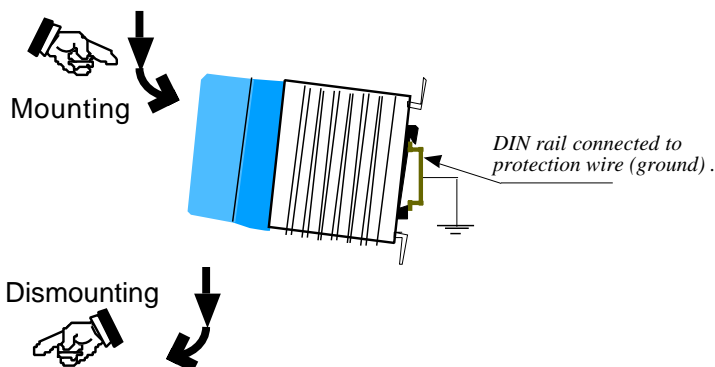

Panel Mounting

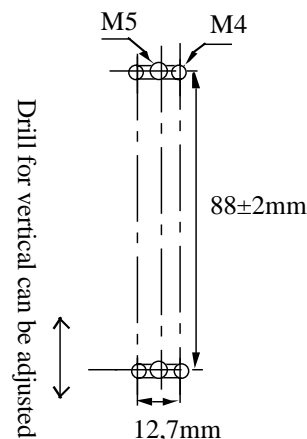

♦ **Warning !** semiconductor relays don't provide any galvanic insulation between the load and the mains. Always use in conjunction with an adapted circuit breaker with isolation feature or a similar device in order to ensure a reliable isolation in the event of wrong function and when the relay must be insulated from the mains (maintenance ; if not used for a long duration ...).



Connections .

◆ For the output terminals, the wire cross sections must be adapted to the load current and to the overcurrent protection device characteristics. The relay rated voltage must be adapted to the mains rated voltage.

◆ celpac use screw clamp connections.



wires (mm ²)	torques	screwdriver
control 1 x(0,75-->2,5) L = 6mm	0,4N.m (0,6N.m max)	3,5x0,5mm
Power 1x(1,5-->16) 1 x(1,5-->10) L = 10mm	1,2N.m (1,8N.m max)	Pozidriv2/ 0,8x5,5 (1x6)

Mounting

◆ Only in vertical position:

The user should protect heat sensitive materials as well as persons against any contacts with the heatsink. For non vertical mounting , the load current must be 50% lower than the rated one . For a good cooling, the SSR needs an air convection. Less convection air produces an abnormal heating. Keep a distance between the upper SSR and the lower SSR. In case of no space between two SSR (zero space between two SSRs) , please reduce the load current. For further details refer to below :

◆ Derating current with no space between SSRs

AC-51 nominal currents are given with a space of 22,5mm between each SSR, for a permanent current during a minimum time of 8 hours in air calm according to IEC60947-4-3. In case of non permanent currents or in case of SSRs are mounted with no space, you must check the heatsink temperature never exceed 90°C. When the SSRs are mounted side to side (no space between each relay) a derating current of 25% must be take into account.

A forced cooling (fan inside the cabinet) improves significantly the thermal performances.

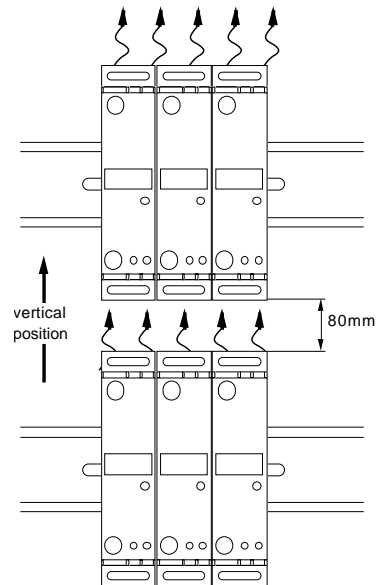

**Typical application :
LOADS**

SILD product is designed mainly for AC-51 résistive load. AC-53 motor current are also given . For other loads, check the inrush current at turn ON and possible overvoltages at turn OFF or consult us :

- * AC-55b : Incandescent lamps : Inrush current is generally 10 times In during few 10ms. So limit the nominal current at about 15A.
- * AC-55a : Electric discharge lamp : These loads often have overcurrent at turn ON and overvoltage at turn OFF, so we advise to use 400VAC SSR on 230VAC mains.
- * AC-56a : Transformers loads : Very high inrush current up to 100 times In . We advise to use random SSR.

Protection :

To protect the SSR against a short-circuit of the load , use a fuse with a I²t value = 1/2 I²t value specified page 2. A test has been made with FERRAZ fuse (see page 2). It is possible to protect SSR by MCB (miniature circuit breaker). In this case, see application note (SSR protection) and use a SSR with high I²t value (5000A²s minimum).

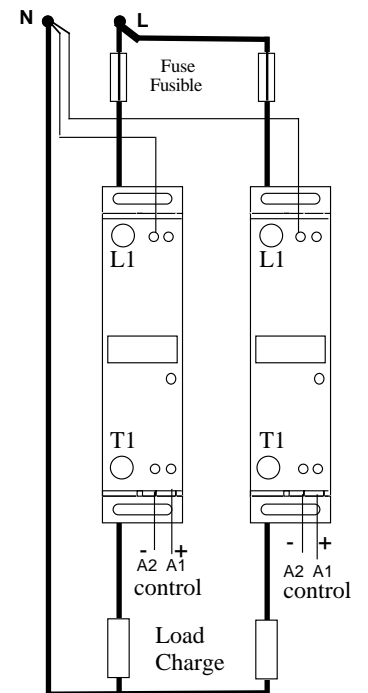

EMC :

◆ Immunity :

We give in our data-sheets, the immunity level of our SSRs according to the main standards for this type of products : EN61000-4-4 & 5. You can see the high immunity level in comparison with the products on the market.

◆ Emission:

SSRs are complex devices which must be interconnected with other equipment (loads, cables,etc.) to form a system. Because the other equipment or the interconnections may not be under the control of celduc, it shall be the responsibility of the system integrator to ensure that systems containing SSRs comply with the requirements of any rules and regulations applicable at the system level.. Consult celduc laboratory which can make some tests in your application.

