



PRELIMINARY

**MOSFET BASED
DC SOLID STATE RELAY**

XKLD31006



Control voltage range	10-30VDC
Max output peak voltage	60V (clamp=40V)
Nom. load current without heatsink	10ADC

- ▶ For DIN RAIL mounting
- ▶ Latest MOSFET technology generation.
- ▶ Ultra low voltage drop.
- ▶ Built-in overvoltage protection
- ▶ Control display LED (green)
- ▶ Applications :
 - Traffic lights
 - Small motors, electromagnets, lights, heaters
 - Measurement products
 - ...

Application voltages	Load current range	Control input voltage range	In & case / Out Insulation	Connections	Dimensions (WxHxD in mm)	Weight
12-24-36VDC	0 to 10A	10-30VDC	2.5kV	Terminal block with screws	12.2 x 76.4 x 53	30g

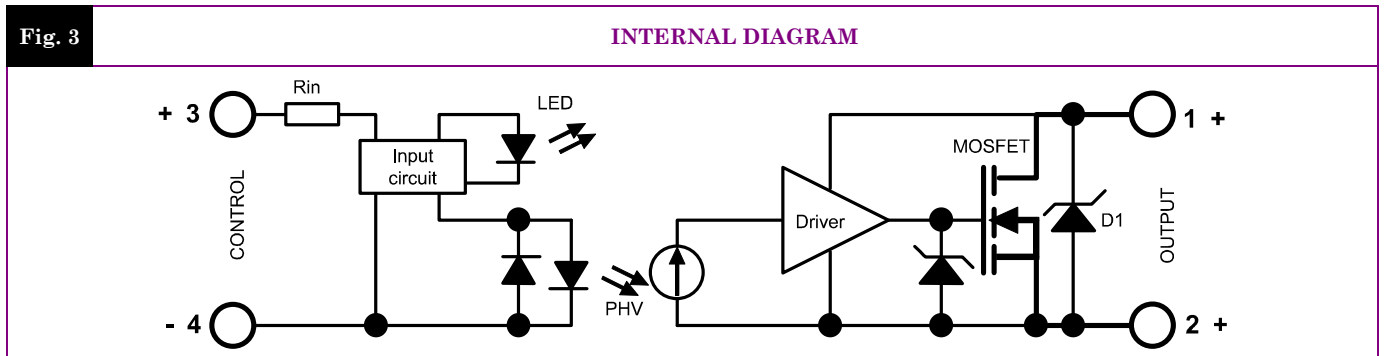
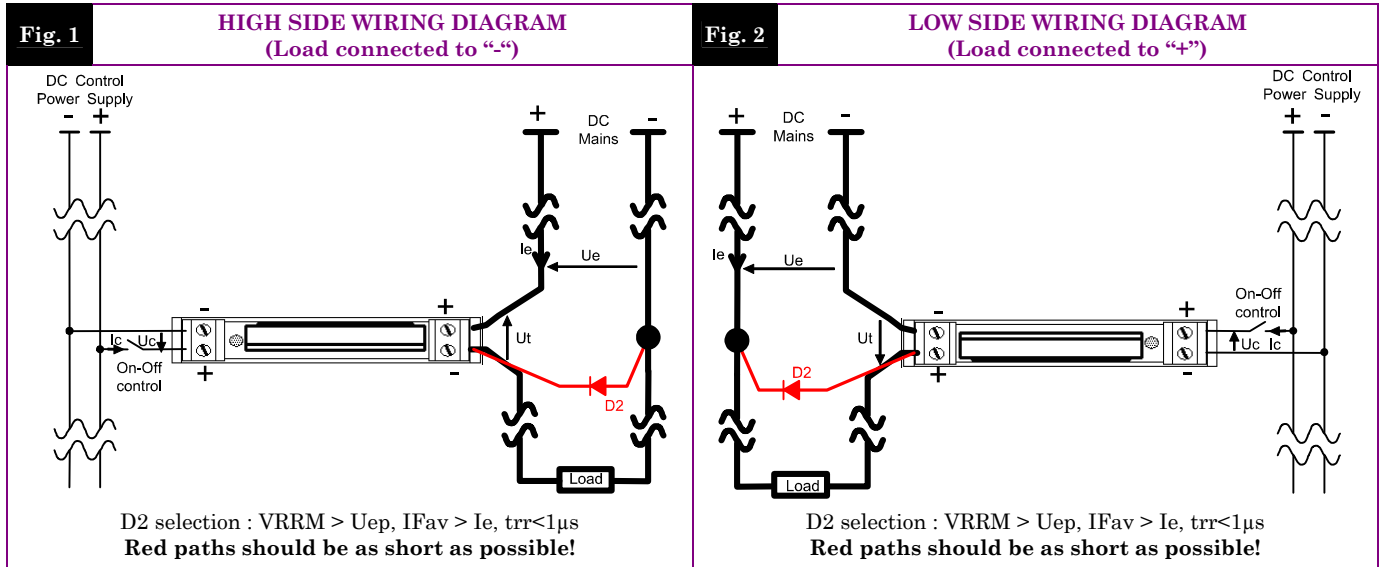

Proud to serve you

PRELIMINARY

CONTROL INPUT CHARACTERISTICS

INPUT CIRCUIT	CHARACTERISTIC	LABEL	VALUE	INFO.
	Nominal control voltage	Ucnom	12-24VDC	
	Nominal control current	Icnom	9-20mADC	
	Control voltage range	Uc	10 – 30VDC	
	Current consumption	Ic	7-26mADC	See fig. 5
	Releasing voltage	Ucoffmax	1VDC	
	Max. reverse voltage	-Ucmax	30VDC	
	Input impedance	Rin	1000Ω	See fig. 5

POWER OUTPUT CHARACTERISTICS

POWER CIRCUIT	CHARACTERISTIC	LABEL	VALUE	INFO.
	Mains Nominal voltage	Uenom	12-24-36VDC	
	Mains voltage range	Ue	10-40VDC	
	Non-repetitive peak voltage	Uep	60V	
	Oversvoltage protection	D1	Pulse = 600W 1.2/50μs Permanent = 0.5W	
	Reverse voltage drop (internal diode)	-Ue	0.82VDC	@Ie=10A @Uc=0
	Maximum nominal currents	Ie	10A	See fig. 7 for limits
	Non-repetitive peak overload current	Iepeak	100A @10ms	See fig. 8
	Min. load current	Iemin	0.1mA	
	Max. leakage current	Ielk	0.1mADC	@Uep @Tjmax
	Max. on-state resistance	RDSon	14mΩ @Tj=25°C 22.4mΩ @Tj=125°C	@Iemax
	Typ. output capacitance	Cout	360pF	@1MHz @VDS=25V @Uc=0
	Junction/case thermal resistance per power element	Rthjc	1K/W	Total = 1 power elements
	Relay/ambient thermal resistance vertically mounted	Rthra	22K/W	@ΔTra=60°C
	Relay thermal time constant	Tthra	2min	@ΔTra=60°C
	Control inputs/power outputs insulation voltage	Uimp	2.5kV	
	Inputs/case insulation voltage	Uimp	2.5kV	
	Outputs/case insulation voltage	Uimp	2.5kV	
	Isolation resistance	Rio	1GΩ	
	Isolation capacitance	Cio	<8pF	
	Maximum junction temperature	Tjmax	175°C	
	Storage ambient temperature	Tstg	-40->+100°C	
	Operating ambient temperature	Tamb	-25->+90°C	See fig. 7
	Max. case temperature	Tc	100°C	

TIME CHARACTERISTICS

Fig. 4

TIME DIAGRAMS

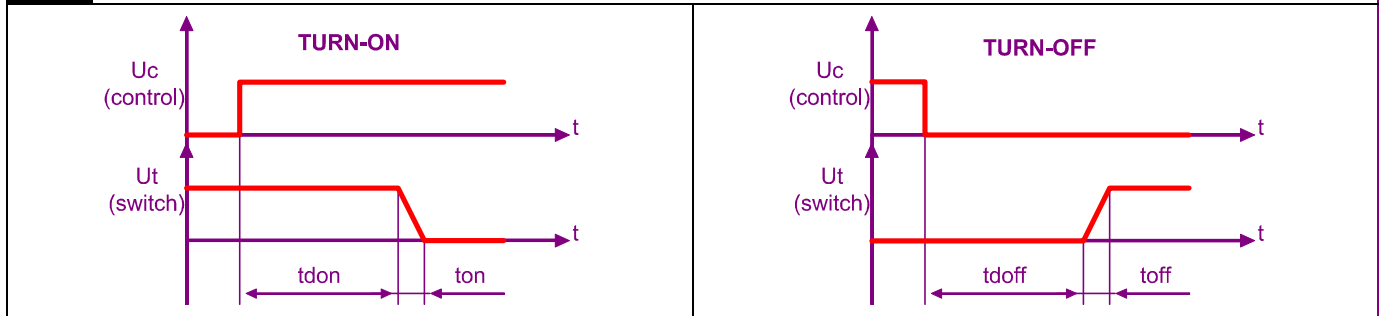

TIME CHARACT.	CHARACTERISTIC	LABEL	VALUE	INFO.
	Turn on time	ton	1μs	
	Turn on delay	tdon	10μs	
	Turn off time	toff	10μs	
	Turn off delay	tdoff	150μs	
Max. On-Off frequency	F_(on-off)	1 to 700Hz depending on the circuit configuration : please consult us		

GENERAL INFORMATION

MISC.	Display LED (control)		Green	
	Housing		UL94V0	
	Mounting		DIN RAIL	
	Noise level		No audible noise	
	Weight		30g	

STANDARDS

GENERAL	Standards		IEC60947-1	
	Protection level		IP00	
	Protection against direct touch		None	
	CE marking		Yes	
	UL, cULUS and VDE approvals		Pending	

E.M.C. IMMUNITY	TYPE OF TEST	STANDARD	LEVEL	EFFECT
	E.S.D. (Electrostatic discharges)	EN61000-4-2	Pending	?
	Radiated electromagnetic fields	EN61000-4-3	Pending	?
	Fast transients bursts	EN61000-4-4	Pending	No effect
	Electric chocks	EN61000-4-5	Pending	?
Voltage drop	EN61000-4-11	-		

E.M.C. EMISSION	Radiated and conducted disturbances	NFEN55011	Pending	
-----------------	-------------------------------------	-----------	---------	--

CHARACTERISTIC CURVES

Fig. 5 INPUT CHARACTERISTIC

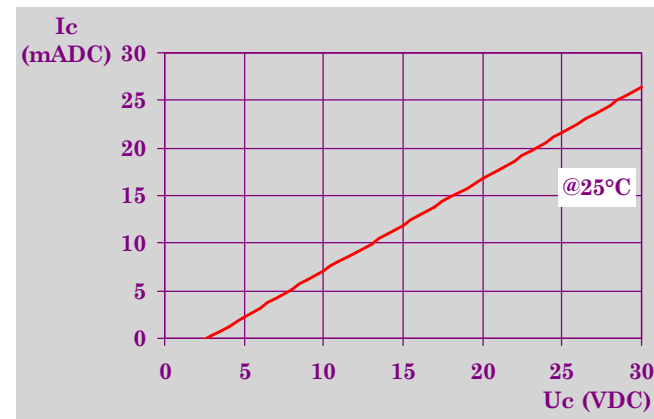

Fig. 6 ON-STATE VOLTAGE DROP VS TEMPERATURE

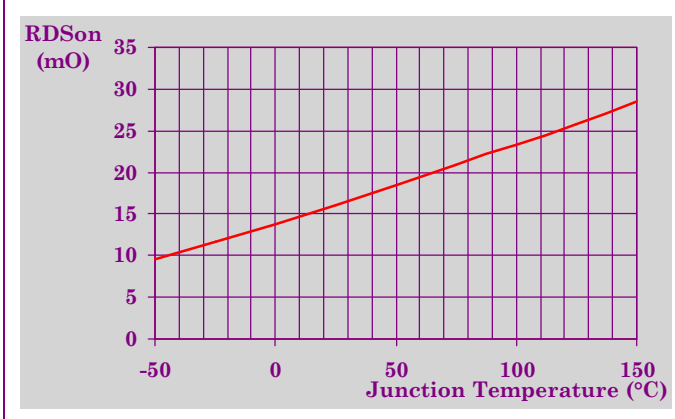

Fig. 7 LOAD CURRENT LIMIT VS TEMPERATURE

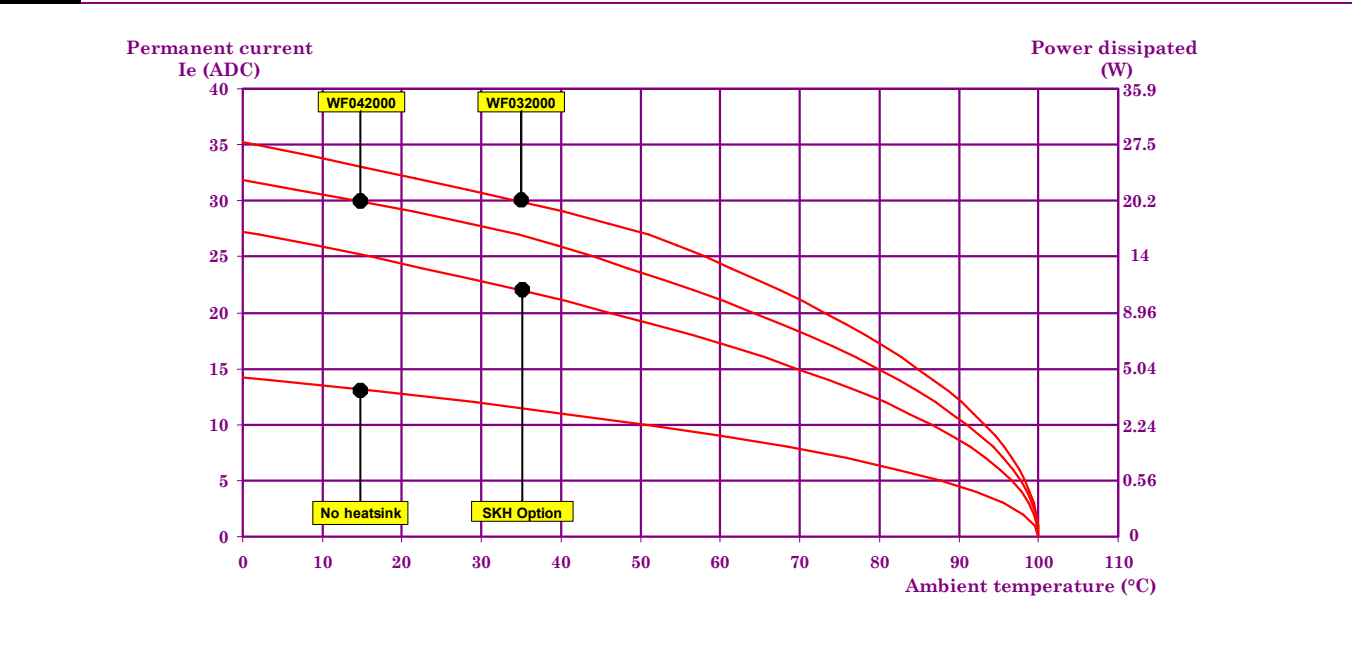

Fig. 8 CURRENT OVERLOAD CHARACTERISTIC (ITSM)

Not available

DIMENSIONS AND ACCESSORIES

Fig. 9

DIMENSIONS

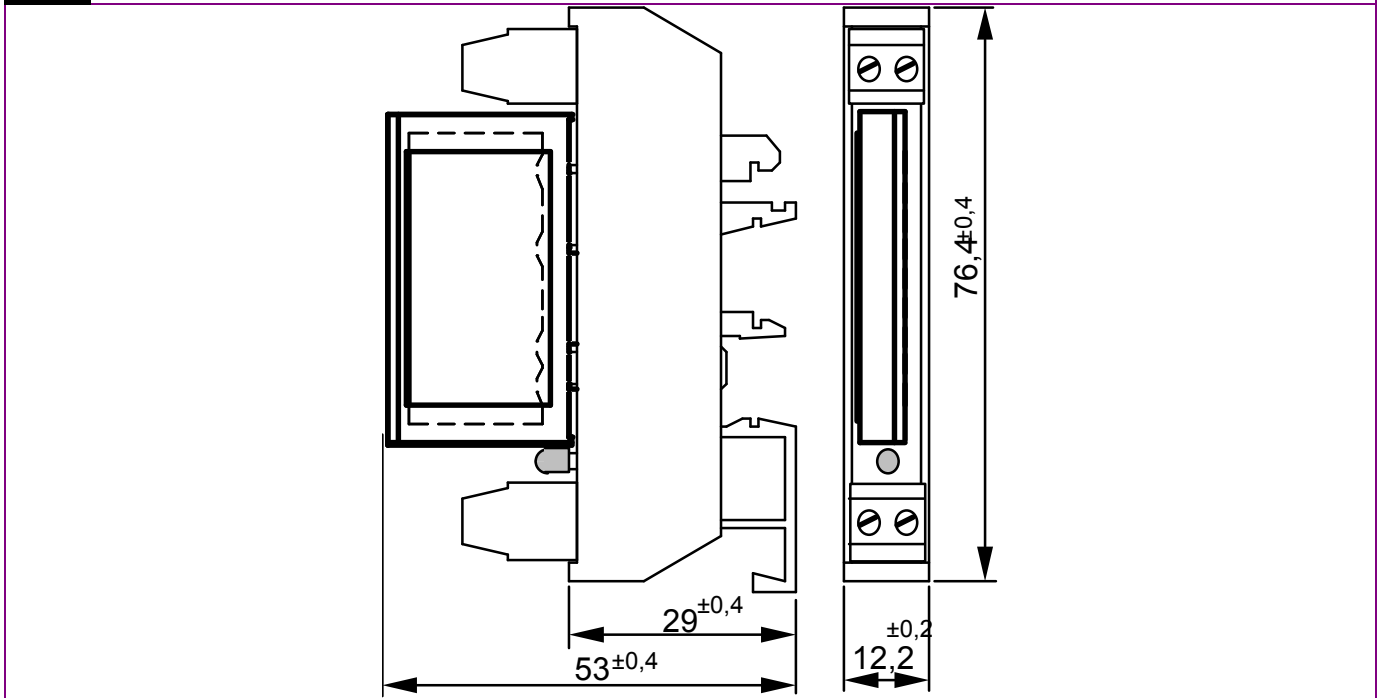

Fig. 10

ACCESSORIES



ISO 9001
N° 1993/1106a

ASSOCIATION
FRANÇAISE POUR
L'ASSURANCE DE
LA QUALITÉ