



## THERMAL Pads

For SU, SA relays

Low thermal resistance

Easy to use

### 5TH24000

For an efficient cooling of power components, it is usual to apply a thermally conducting media, such as thermal grease, between the power element and the heatsink.

Thermal grease is considered problematic due to difficulties in applying it to the heat-dissipating surface and also performances in the life of the product.

An alternative, **celduc** tested a range of products and compared their thermal resistance characteristics (Rth c/h : Thermal Resistance between case to heatsink)

**celduc** recommends Aluminium materials thermal pads with very good thermal performances and no modification in the long term. (See comparison tests on last page):



These thermal PAD with very good thermal conduction have also an electrical conduction. So all the mechanical parts stay connected to the earth. With some silicone thermal PAD the earth conduction is not achieved

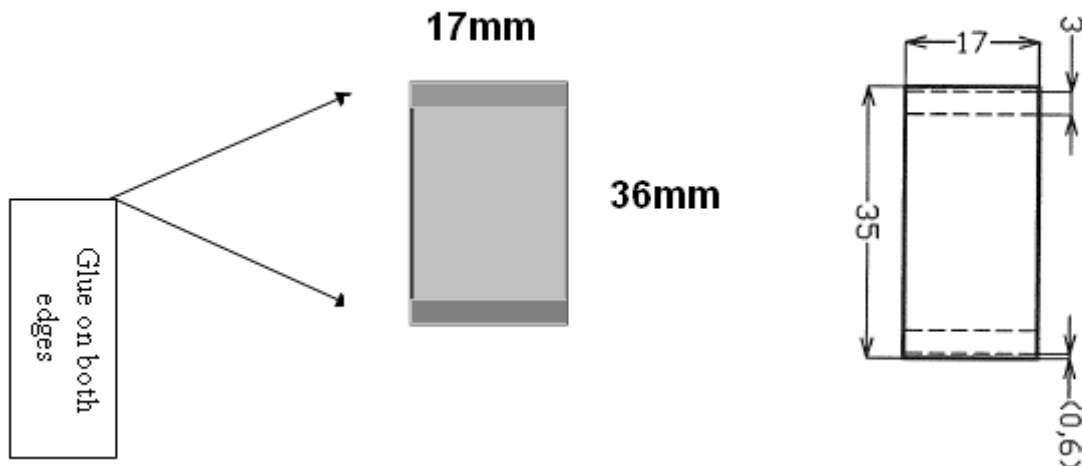



### **celduc thermal pads performances :**

5THxxx thermal PAD is a thermally conductive phase change material coated on both sides of aluminium foil. At temperatures greater than 52°C, 5THxxx changes into a molten state and, under low closure force, wets the heat sink and component surfaces to create a very thin, low thermal resistance interface. 5THxxx has great heat spreading characteristics and won't flow from the interface. 5THxxx has superior thermal performance comparable to the highest performing grease and phase change products available.

#### **Typical Properties**

<b>Colour</b>	Gray
<b>Thickness</b>	0.003" (0.076mm)
<b>Standard Coating Thickness per side</b>	0.0005" (0.013mm)
<b>Density</b>	2.1 g/cc
<b>Shelf Life</b>	Indefinite
<b>UL Flammability Rating</b>	94 V0
<b>Maximum Use Temperature</b>	200°C
<b>Phase Change Softening Temperature</b>	52°C
<b>Thermal Impedance</b>	
@ 5 psi	0.03 °C-in <sup>2</sup> /W
@ 34.5 Kpa	0.193 °C-cm <sup>2</sup> /W

**With the 5TH24000 adhesive thermal PAD, as glue is only on the edges, there is no incidence in terms of thermal performances.**



**Delivered in roll:**

