



## **MOSFET BASED DC SOLID-STATE RELAY**

- ▶ Latest MOSFET technology generation.
- ▶ Ultra low on-state resistance.
- ▶ New innovative isolated driver ensuring fast power transistor turn on and off therefore low power transient.
- ▶ Ultra low output leakage current
- ▶ Low control current consumption
- ▶ Triggered control input to avoid linear control risks
- ▶ Low conducted and radiated disturbances

# SCM0150100



Control voltage range	<b>4.5-32VDC</b>
Max transient peak voltage	<b>100v</b>
Advised max. DC Mains peak voltage	Depend on the voltage protection
Max. Load Current (with heatsink)	<b>150ADC</b>

DC Mains voltage range	Load current range	Control input voltage range	In & case / Out Insulation	Connections	Dimensions (WxHxD)	Weight
(Depends on protection clamping voltage)	0 to 150A (with heatsink)	4.5-32VDC	4kV	M3 round tabs M5 round tabs	44.5 x 58.2 x 27 (mm)	100g

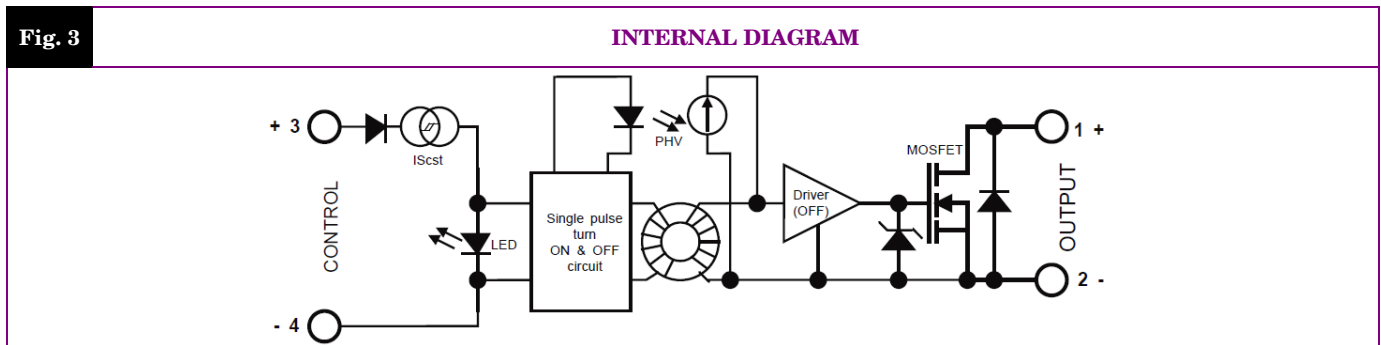
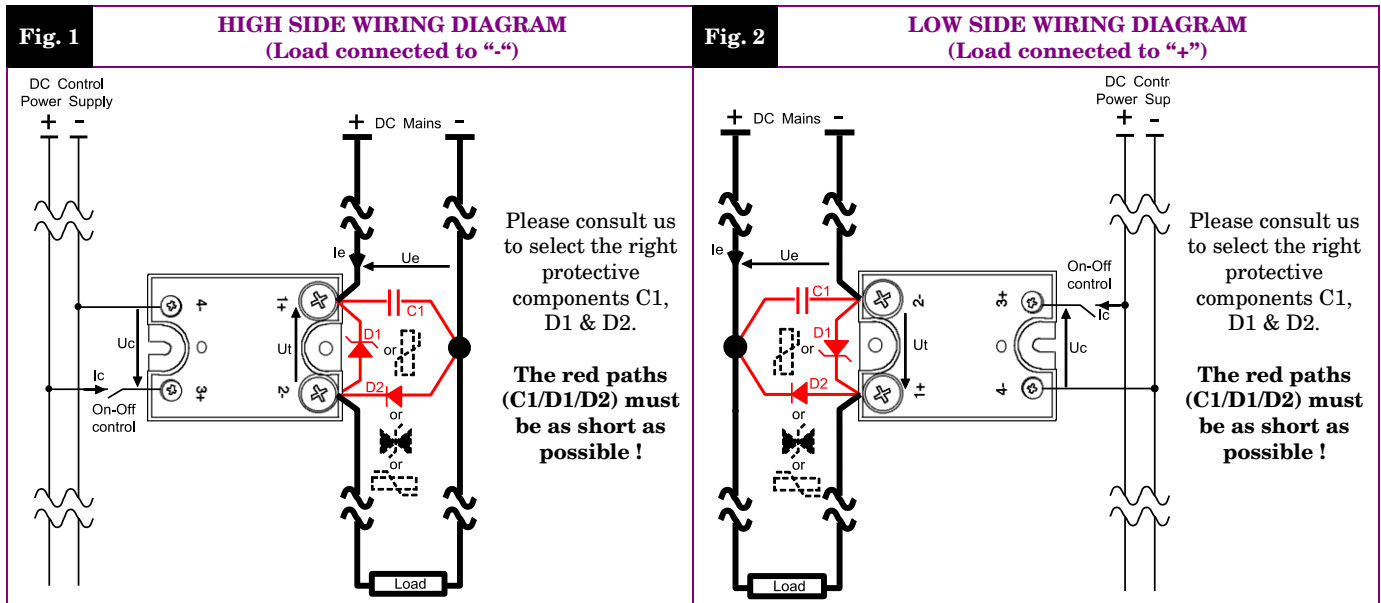

*Proud to serve you*

## CONTROL INPUT CHARACTERISTICS

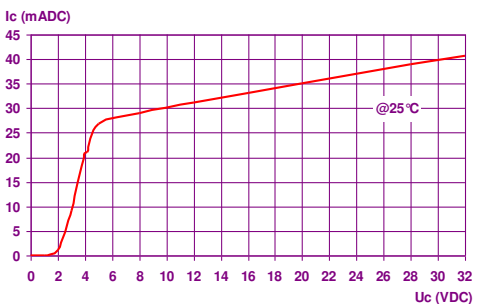
INPUT CIRCUIT	CHARACTERISTIC	LABEL	VALUE	INFO.	<b>Fig. 4</b> <b>CONTROL CURRENT vs. CONTROL VOLTAGE</b>	
	Nom. Control voltage	<b>U<sub>cnom</sub></b>	12-24VDC			
	Nom. Control current	<b>I<sub>cnom</sub></b>	35mADC			
	Control voltage range	<b>U<sub>c</sub></b>	4.5 – 32VDC	typical=4.3V		
	Control current consumption	<b>I<sub>c</sub></b>	25 – 42mADC	See curve		
	Releasing control voltage	<b>U<sub>coffmax</sub></b>	1VDC	Typical= 3.5V		
	Max. reverse control voltage	<b>-U<sub>cmax</sub></b>	32VDC	-I <sub>cmax</sub> <100µA		
	Input impedance	<b>R<sub>in</sub></b>	Current limitation	See curve		

## TIME CHARACTERISTICS

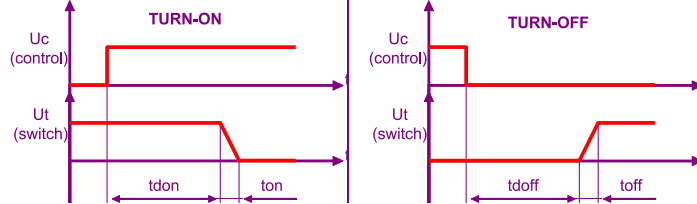
TIME CHARACT.	CHARACTERISTIC	LABEL	VALUE		
	Turn on time	<b>ton</b>	10µs		
	Turn on delay	<b>tdon</b>	600µs		
	Turn off time	<b>toff</b>	10µs		
	Turn off delay	<b>tdoff</b>	100µs		
	Max. On-Off frequency	<b>F<sub>(on-off)</sub></b>	700Hz		

## POWER OUTPUT CHARACTERISTICS

POWER CIRCUIT	CHARACTERISTIC	LABEL	VALUE	INFO.	
	Mains voltage range	<b>U<sub>t</sub></b>   <b>U<sub>e</sub></b>	<b>Min = R<sub>Dson</sub> x I<sub>e</sub></b>		Depends on protection clamping voltage (D1)
	Non-repetitive peak voltage	<b>U<sub>tp</sub></b>	100V		
	Oversvoltage protection	<b>D1</b>	Not integrated A voltage clamping mean must be connected across the terminals 1 & 2 (see fig 1 & 2)		Please consult us to select the right protective components
	Off-state max reverse voltage drop (internal diode)	<b>-U<sub>t</sub></b>	0.7V		@I <sub>e</sub> =150A @U <sub>c</sub> =0
	Maximum nominal currents	<b>I<sub>e max</sub></b>	<b>Resistive</b> 150A	<b>Motor</b> Please contact us	<b>See fig. 9</b>
	Max. non-repetitive peak current	<b>I<sub>epeak</sub></b>	390A		@T <sub>c</sub> =100°C @T <sub>j</sub> =175°C @U <sub>tp</sub> (See fig. 8)
	Min. load current	<b>I<sub>e min</sub></b>	0mA		
	Max. leakage current	<b>I<sub>elk max</sub></b>	500µA		@U <sub>tp</sub> @T <sub>jmax</sub>
	Max. on-state resistance	<b>R<sub>Dson</sub></b>	1.3mOhms @T <sub>j</sub> =25°C	2.3mOhms @T <sub>j</sub> =125°C	@I <sub>e max</sub>
	Typ. output capacitance	<b>C<sub>out</sub></b>	3nF		@U <sub>tp</sub>
	Junction/case thermal resistance	<b>R<sub>thjc</sub></b>	0.59K/W		
	Built-in heatsink thermal resistance vertically mounted	<b>R<sub>thra</sub></b>	10K/W		@ΔT <sub>ra</sub> =75°C
	Heatsink thermal time constant	<b>T<sub>thra</sub></b>	10 minutes		@ΔT <sub>ra</sub> =60°C
	Control inputs/power outputs insulation voltage	<b>U<sub>imp</sub></b>	4kV		
	Inputs/case insulation voltage	<b>U<sub>imp</sub></b>	4kV		
	Outputs/case insulation voltage	<b>U<sub>imp</sub></b>	4kV		
	Isolation resistance	<b>R<sub>io</sub></b>	1GΩ		
	Isolation capacitance	<b>C<sub>io</sub></b>	<8pF		
	Maximum junction temperature	<b>T<sub>jmax</sub></b>	175°C		
	Storage ambient temperature	<b>T<sub>stg</sub></b>	-40->+100°C		
	Operating ambient temperature	<b>T<sub>amb</sub></b>	-40->+90°C		<b>See fig. 9</b>
	Max. case temperature	<b>T<sub>c</sub></b>	100°C		

## OUTPUT SWITCH CHARACTERISTIC CURVES

**Fig. 5 ON RESISTANCE VS JUNCTION TEMPERATURE**

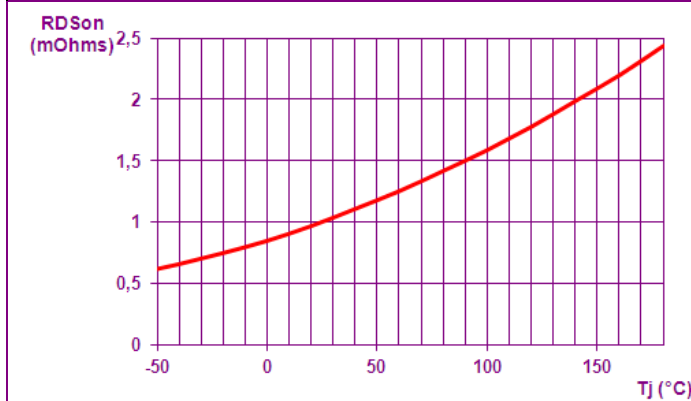

**Fig. 6 REVERSE VOLTAGE DROP VS REVERSE CURRENT**

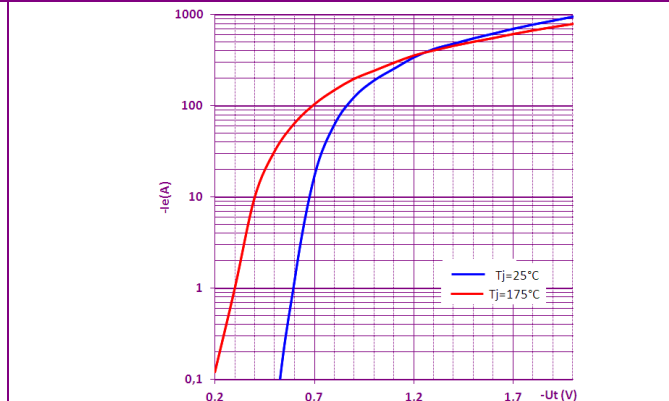

**Fig. 7 POWER ELEMENT TRANSIENT THERMAL IMPEDANCE vs. PULSE DURATION**

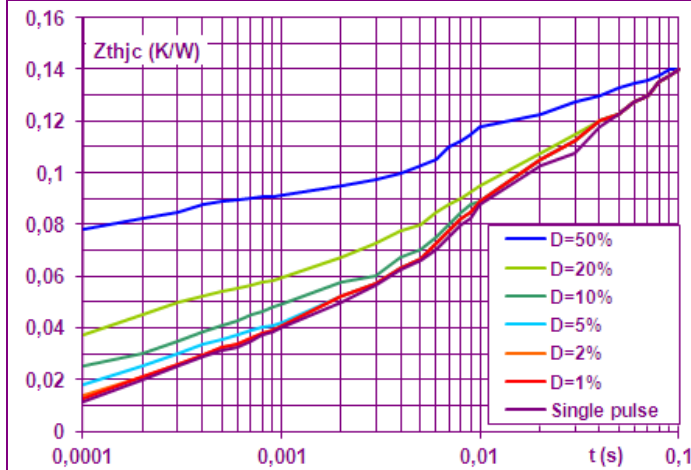

**Fig. 8 ON-STATE PEAK OVERLOAD CURRENT vs. PULSE DURATION**

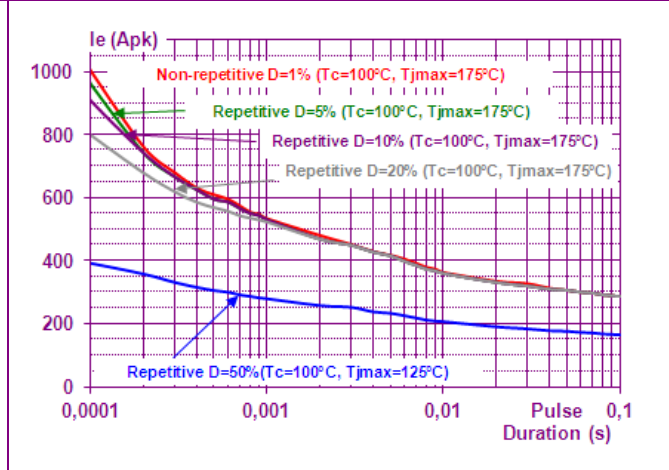

**Fig. 9 POWER DISSIPATED AND LOAD CURRENT LIMIT VS TEMPERATURE**

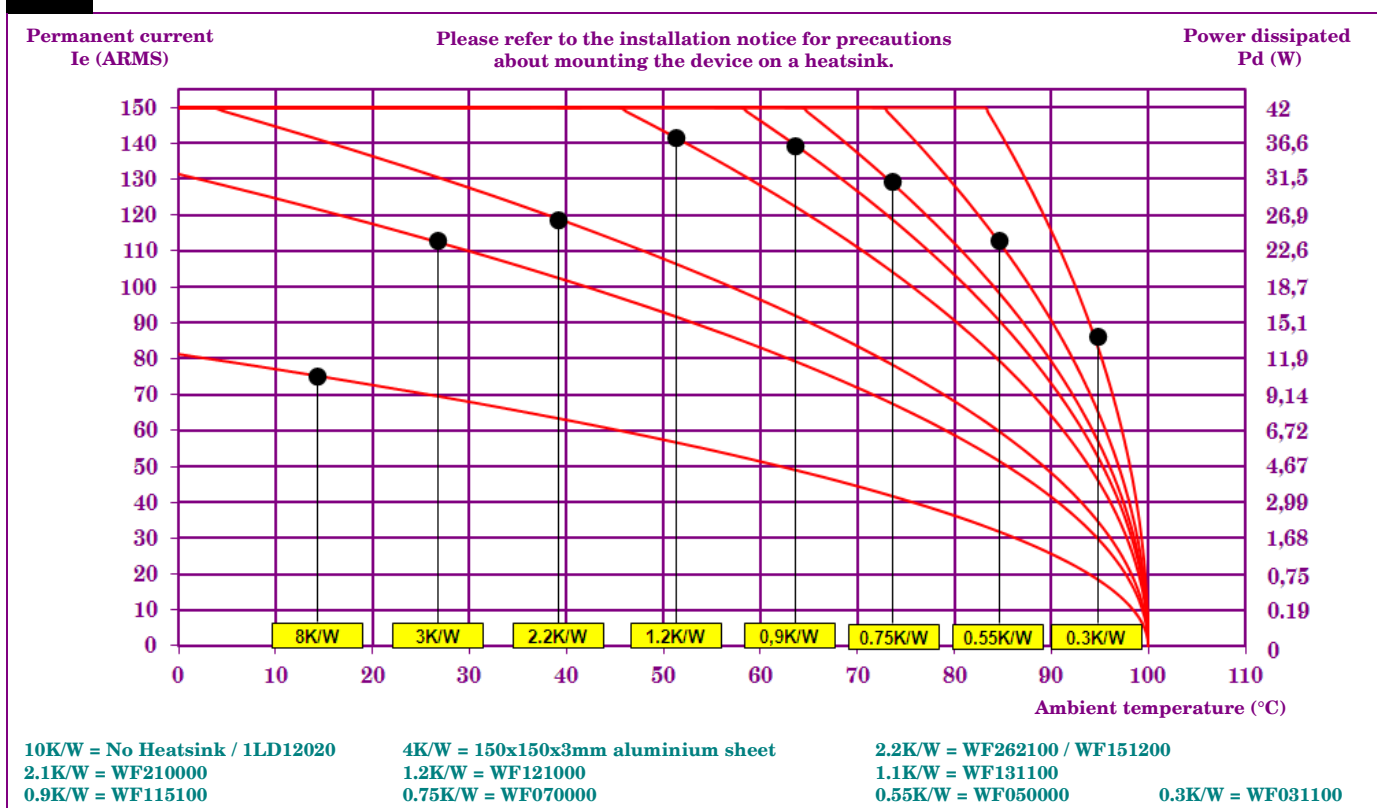



**GENERAL INFORMATION**

CONNECTIONS	Connections	Power	Control
	Screwdriver advised	Philips™ NR2	Philips™ NR1
	Min and max tightening torque	1.8 N.m	0.8 N.m
	Insulated crimp terminals (round tabs, eyelet type)	M5	M3

MISC.	Display	Green LED (indicates relay has switched ON)	
	Housing	UL94V0	
	Mounting	2 screws (M4x12mm)	See mounting sheet
	Noise level	No audible noise	
	Weight	100g	

**STANDARDS**

GENERAL	Standards	IEC60947-1
	Protection level	IP00
	Protection against direct touch	None
	CE marking	Yes
	UL, cULUS and VDE approvals	Pending

E.M.C. IMMUNITY	TYPE OF TEST	STANDARD	LEVEL	EFFECT
	E.S.D. (Electrostatic discharges)	EN61000-4-2	Pending	?
	Radiated electromagnetic fields	EN61000-4-3	Pending	?
	Fast transients bursts	EN61000-4-4	Pending	No effect
	Electric chocks	EN61000-4-5	Pending	?
	Voltage drop	EN61000-4-11	-	

E.M.C. EMISSION	Radiated and conducted disturbances	NFEN55011	Pending



**DIMENSIONS AND ACCESSORIES**

**Fig. 10**

**DIMENSIONS (mm)**

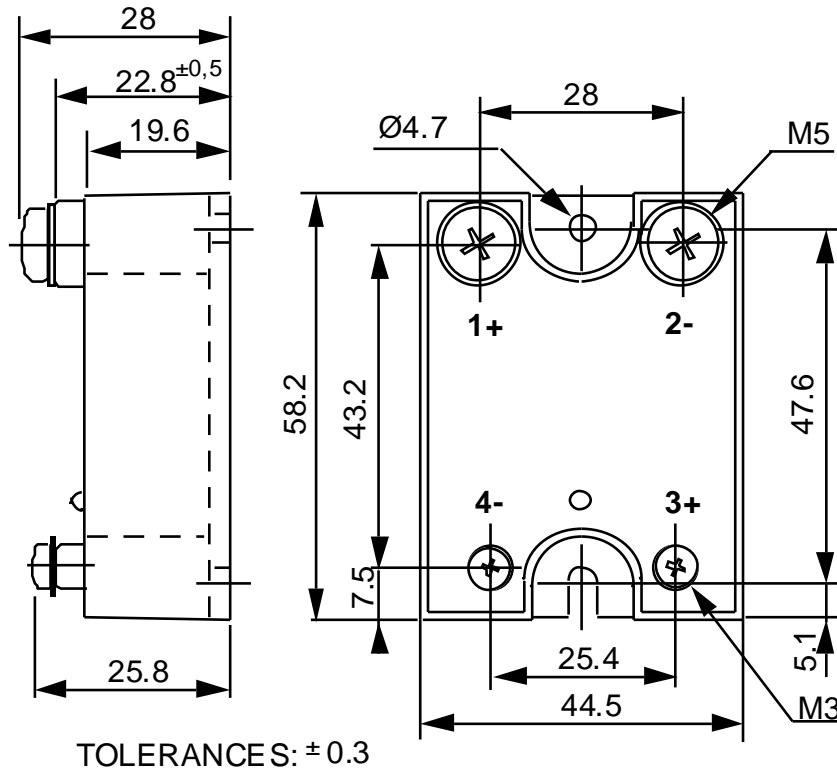

**ACCESSORIES**

**PROTECTIVE COVER  
1K470000**

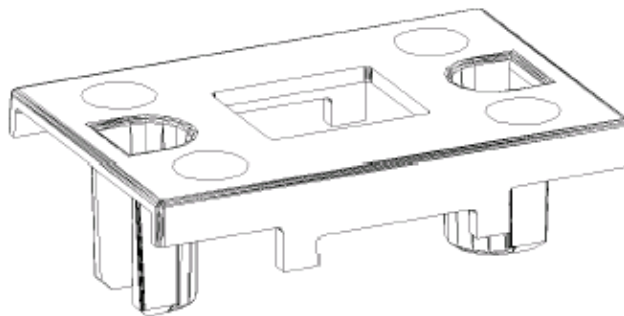

Please consult our website for other accessory references  
(Heatsinks, mounting adaptors, thermal grease...)