



**PRELIMINARY DATA**

**MOSFET BASED  
DC SOLID-STATE RELAY**

- ▶ Latest MOSFET technology generation.
- ▶ Ultra low on-state resistance.
- ▶ Low output leakage current.
- ▶ Low control current consumption.
- ▶ Built-in overvoltage protection
- ▶ Reverse protected triggered control input to avoid linear control risks
- ▶ No radiated or conducted disturbances
- ▶ Touch protected housing IP20

**SOM020100**



Control voltage range	<b>3.5-32VDC</b>
Max. permanent output voltage	<b>60VDC</b>
Max. load current with heatsink	<b>20ADC</b>

Load voltage range	Load current range	Control input voltage range	In & case / Out Insulation	Connexions	Dimensions (WxHxD)	Weight
5-60VDC	Up to 20A (with heatsink)	3.5-32VDC	2.5kV	Screw terminals	45 x 58.5 x 30	80g

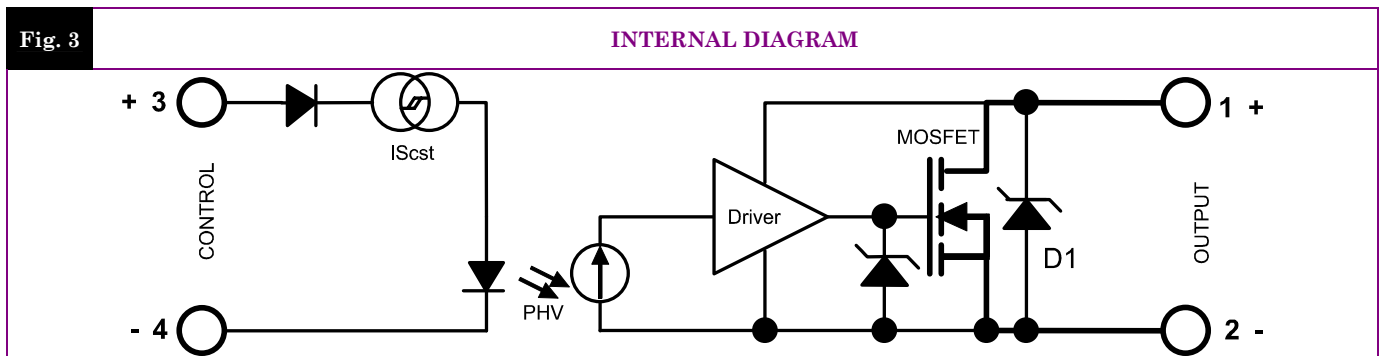
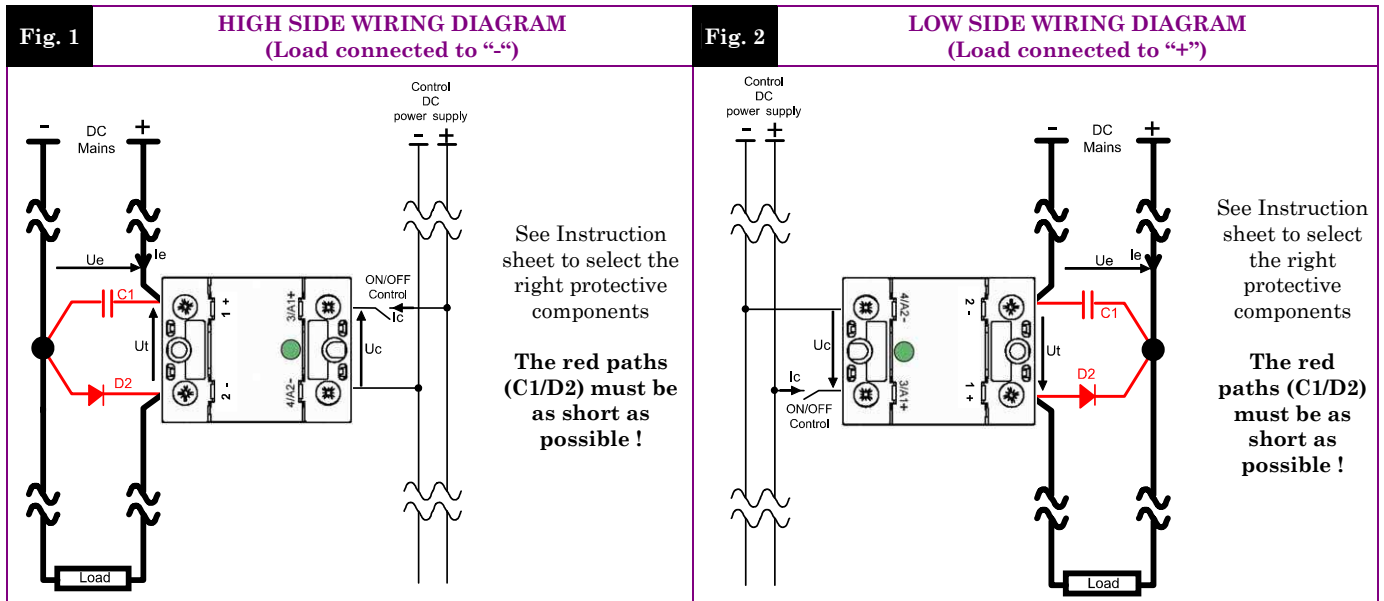

*Proud to serve you*



**PRELIMINARY DATA**

**CONTROL INPUT CHARACTERISTICS**

INPUT CIRCUIT	CHARACTERISTIC	LABEL	VALUE	INFO.
	Nom. Control voltage	<b>Ucnom</b>	12-24VDC	
	Min. Control current	<b>Icmin</b>	35mADC	-100µA/°C
	Control voltage range	<b>Uc</b>	3.5 – 32VDC	typical ON=3.3V
	Control current consumption	<b>Ic</b>	32 – 35mADC (for control voltage range)	<b>See fig. 5</b>
	Releasing control voltage	<b>Ucoffmax</b>	1VDC	typical OFF= 2.6V
	Max. reverse control voltage	<b>-Ucmax</b>	32VDC	-Icmax<100µA
	Input impedance	<b>Rin</b>	Current limitation	<b>See fig. 5</b>

**POWER OUTPUT CHARACTERISTICS**

POWER CIRCUIT	CHARACTERISTIC	LABEL	VALUE	INFO.	
	Nominal voltage	<b>Uenom</b>	48VDC		
	Voltage range	<b>Ut</b>   <b>Ue</b>	5-60VDC		
	Non-repetitive peak voltage	<b>Utp</b>	100V		
	Overvoltage protection	<b>D1</b>	Transient voltage suppressor 56V (1500W/1ms)		
	Max reverse voltage drop (internal diode at OFF state)	<b>-Ut</b>	1.3V	@Ie=50A @Uc=0	
	Maximum nominal currents	<b>Ie max</b>	<b>Resistive</b> 20A	<b>Motor</b> Please contact us	<b>See fig. 7 (limits)</b>
	Non-repetitive peak overload current	<b>Id max</b>	200A		<b>See fig. 8</b>
	Min. load current	<b>Iemin</b>	5mA		
	Max. leakage current	<b>Ielk max</b>	3mA		@Utmax @Tjmax
	Max. on-state resistance	<b>RDSon</b>	56mΩ		@Iemax @Tjmax
	Typ. output capacitance	<b>Cout</b>	0.3nF		
	Junction/case thermal resistance per power element	<b>Rthjc</b>	1.4K/W		
	Built-in heatsink thermal resistance vertically mounted	<b>Rthra</b>	10K/W		@ΔTra=75°C
	Heatsink thermal time constant	<b>Tthra</b>	10 minutes		@ΔTra=55°C
	Control inputs/power outputs insulation voltage	<b>Uimp</b>	2.5kV		
	Inputs/case insulation voltage	<b>Uimp</b>	2.5kV		
	Outputs/case insulation voltage	<b>Uimp</b>	2.5kV		
	Isolation resistance	<b>Rio</b>	1GΩ		
	Isolation capacitance	<b>Cio</b>	<8pF		
	Maximum junction temperature	<b>Tjmax</b>	175°C		
	Storage ambient temperature	<b>Tstg</b>	-40->+100°C		
	Operating ambient temperature	<b>Tamb</b>	-25->+90°C		<b>See fig. 7</b>
	Max. case temperature	<b>Tc</b>	100°C		

**PROTECTION CHARACTERISTICS**

PROTECTION	Leakage current (Ielk) vs DC voltage (Ut)	Absolute limits
<p><b>Ielk</b> : Leakage current of the relay  <b>Ie</b> : User load nominal current  <b>Utp</b> : Relay max. non repetitive peak voltage</p>	<p><b>Utmax</b> : Max. nominal voltage of the relay  <b>Uto</b> : Possible overvoltage above Utmax  <b>Utn = Ue</b> : User DC power supply voltage</p>	<p><b>t</b> : Overvoltage duration  <b>T</b> : Time between 2 overvoltage</p>



**TIME CHARACTERISTICS**

Fig. 4

TIME DIAGRAMS

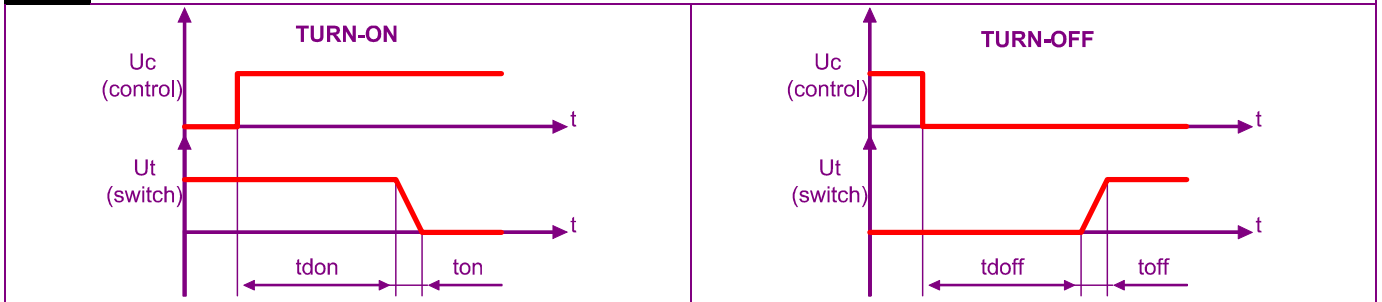

TIME CHARACT.	CHARACTERISTIC	LABEL	VALUE	INFO.
	Turn on time	<b>ton</b>	20µs	
	Turn on delay	<b>tdon</b>	20µs	
	Turn off time	<b>toff</b>	20µs	
	Turn off delay	<b>tdoff</b>	20µs	
	Max. On-Off frequency	<b>F<sub>(on-off)</sub></b>	>1000Hz (for high frequency, take 2 x Ie to calculate the heatsink; the protections must be chosen carefully)	Refer to the instruction sheet

**GENERAL INFORMATION**

CONNECTIONS	Connections		Power		Control	
	Screwdriver advised		POZIDRIV2			
	Min and max tightening torque		2 N.m		1.2 N.m	
	Insulated crimp terminals (round tabs, eyelet type)		M5		M4	

MISC.	Display		Green LED (indicates relay has switched ON)		
	Housing		UL94V0		
	Mounting		2 screws (M4x12mm ; tightening = 1.2N.m)		See mounting sheet
	Noise level		None		
	Weight		80g		

**STANDARDS**

GENERAL	Standards		IEC60947-1		
	Protection level		IP20		
	Protection against direct touch		Yes		
	CE marking		Yes		
	UL, cULUS and VDE approvals		Pending		

E.M.C. IMMUNITY	TYPE OF TEST	STANDARD	LEVEL	EFFECT
	E.S.D. (Electrostatic discharges)	EN61000-4-2	Pending	?
	Radiated electromagnetic fields	EN61000-4-3	Pending	?
	Fast transients bursts	EN61000-4-4	Pending	?
	Electric chocks	EN61000-4-5	Pending	?
Voltage drop	EN61000-4-11	-		

E.M.C. EMISSION				
	Radiated and conducted disturbances	NFEN55011	Pending	



**CHARACTERISTIC CURVES**

**Fig. 5 INPUT CHARACTERISTIC**

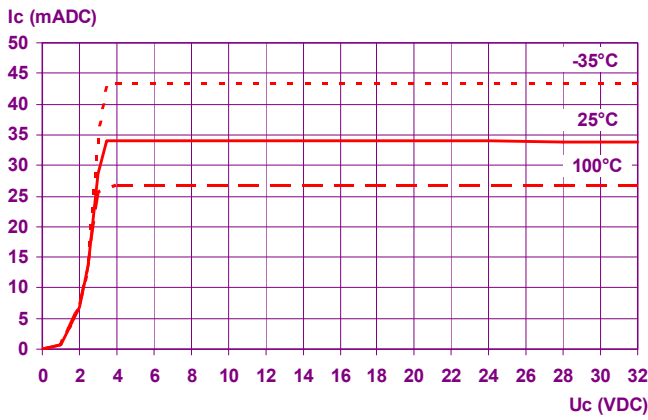

**Fig. 6 ON RESISTANCE VS JUNCTION TEMPERATURE**

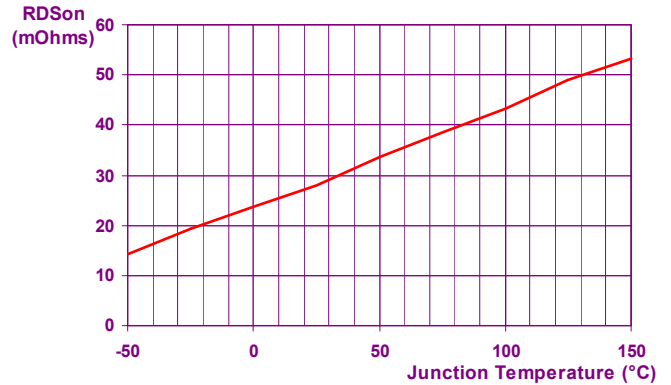

**Fig. 7 POWER DISSIPATED AND LOAD CURRENT LIMIT VS TEMPERATURE**

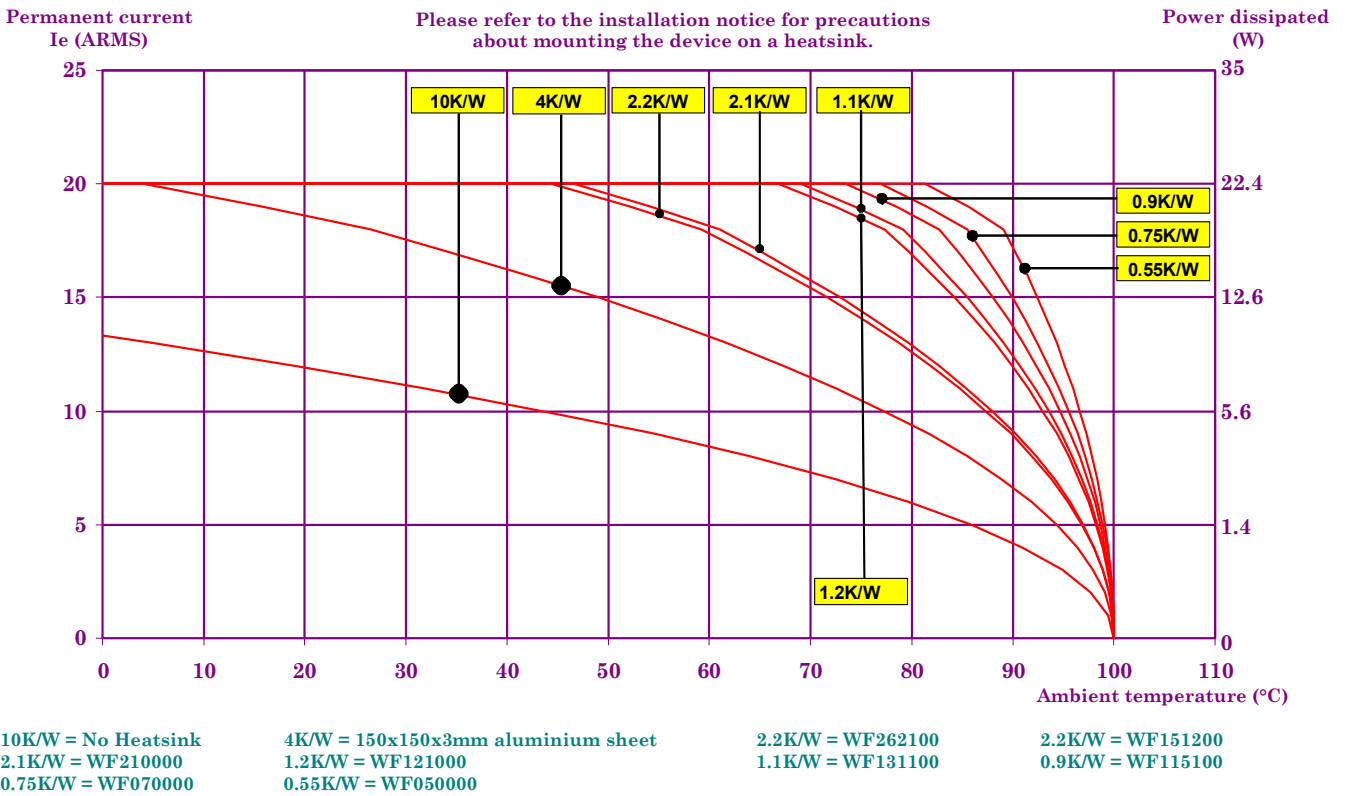

**Fig. 8 PEAK OVERLOAD CURRENT vs. PULSE DURATION CHARACTERISTIC**

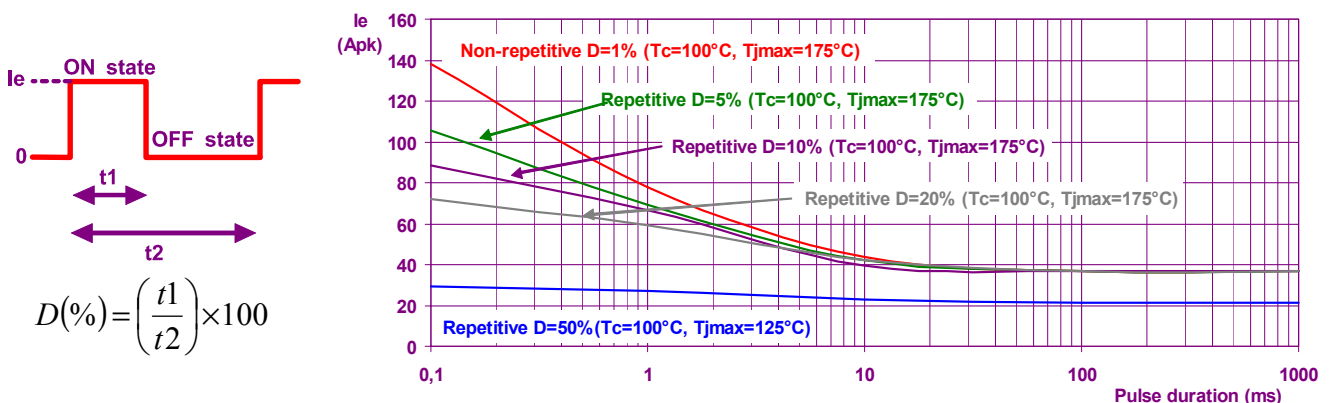



**DIMENSIONS AND ACCESSORIES**

Fig. 9

DIMENSIONS (mm)

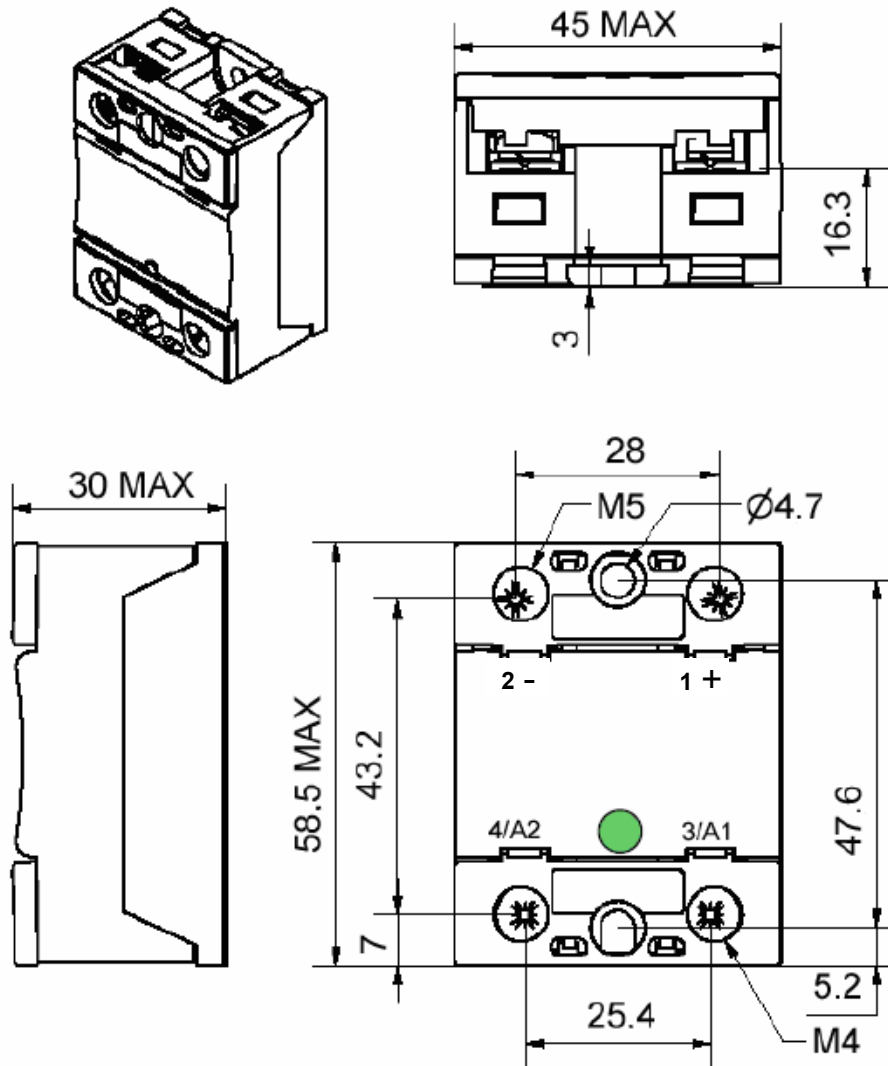

Fig. 10

ACCESSORIES

FASTON : Please contact us



ISO 9001  
N° 1993/1106a

ASSOCIATION  
FRANÇAISE POUR  
L'ASSURANCE DE  
LA QUALITÉ