



PRELIMINARY DATA

**MOSFET BASED
DC SOLID-STATE RELAY**

- ▶ Latest MOSFET technology generation.
- ▶ Ultra low on-state resistance.
- ▶ Low output leakage current.
- ▶ Low control current consumption.
- ▶ Built-in overvoltage protection
- ▶ Reverse protected triggered control input to avoid linear control risks
- ▶ No radiated or conducted disturbances
- ▶ Touch protected housing IP20

SOM040100



Control voltage range	3.5-32VDC
Max. permanent output voltage	60VDC
Max. load current with heatsink	40ADC

Load voltage range	Load current range	Control input voltage range	In & case / Out Insulation	Connections	Dimensions (WxHxD)	Weight
5-60VDC	Up to 40A (with heatsink)	3.5-32VDC	2.5kV	Screw terminals	45 x 58.5 x 30	80g

Fig. 1 HIGH SIDE WIRING DIAGRAM (Load connected to “-“) **Fig. 2 LOW SIDE WIRING DIAGRAM (Load connected to “+“)**

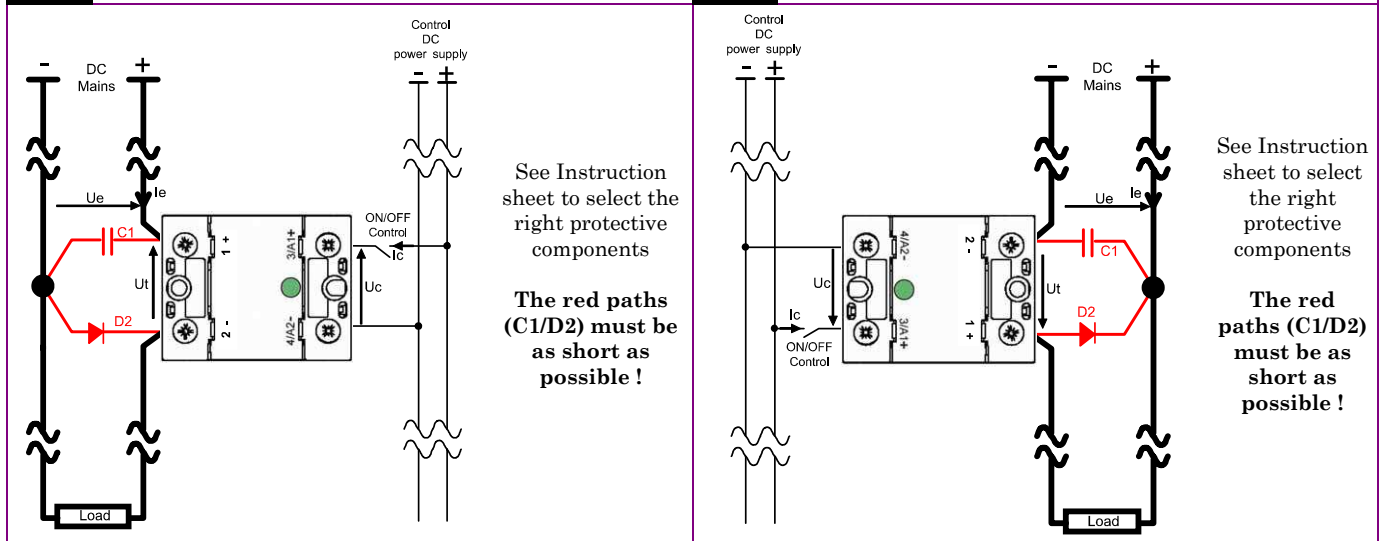
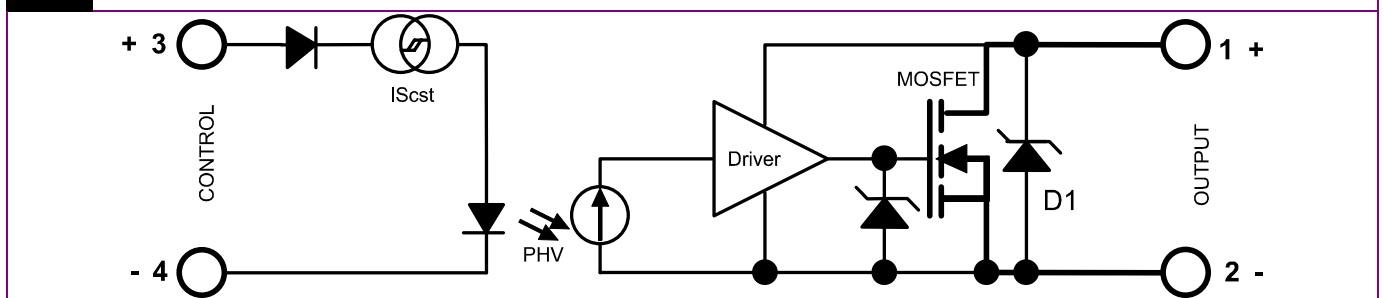

Fig. 3 INTERNAL DIAGRAM



Proud to serve you

CONTROL INPUT CHARACTERISTICS

INPUT CIRCUIT	CHARACTERISTIC	LABEL	VALUE	INFO.
	Nom. Control voltage	Ucnom	12-24VDC	
	Min. Control current	Icmin	35mADC	-100µA/°C
	Control voltage range	Uc	3.5 – 32VDC	typical ON=3.3V
	Control current consumption	Ic	32 – 35mADC (for control voltage range)	See fig. 5
	Releasing control voltage	Ucoffmax	1VDC	typical OFF= 2.6V
	Max. reverse control voltage	-Ucmax	32VDC	-Icmax<100µA
	Input impedance	Rin	Current limitation	See fig. 5

POWER OUTPUT CHARACTERISTICS

POWER CIRCUIT	CHARACTERISTIC	LABEL	VALUE	INFO.	
	Nominal voltage	Uenom	48VDC		
	Voltage range	Ut Ue	5-60VDC		
	Non-repetitive peak voltage	Utp	100V		
	Overvoltage protection	D1	Transient voltage suppressor 56V (1500W/1ms)		
	Max reverse voltage drop (internal diode at OFF state)	-Ut	1.3V	@Ie=80A @Uc=0	
	Maximum nominal currents	Ie max	Resistive 40A	Motor Please contact us	See fig. 7 (limits)
	Non-repetitive peak overload current	Id max	320A		See fig. 8
	Min. load current	Iemin	5mA		
	Max. leakage current	Ielk max	3mA		@Utmax @Tjmax
	Max. on-state resistance	RDSon	30mOhms		@Iemax @Tjmax
	Typ. output capacitance	Cout	0.7nF		
	Junction/case thermal resistance per power element	Rthjc	0.9K/W		
	Built-in heatsink thermal resistance vertically mounted	Rthra	10K/W		@ΔTra=75°C
	Heatsink thermal time constant	Tthra	10 minutes		@ΔTra=75°C
	Control inputs/power outputs insulation voltage	Uimp	2.5kV		
	Inputs/case insulation voltage	Uimp	2.5kV		
	Outputs/case insulation voltage	Uimp	2.5kV		
	Isolation resistance	Rio	1GΩ		
	Isolation capacitance	Cio	<8pF		
	Maximum junction temperature	Tjmax	175°C		
	Storage ambient temperature	Tstg	-40->+100°C		
	Operating ambient temperature	Tamb	-25->+90°C		See fig. 7
	Max. case temperature	Tc	100°C		

PROTECTION CHARACTERISTICS

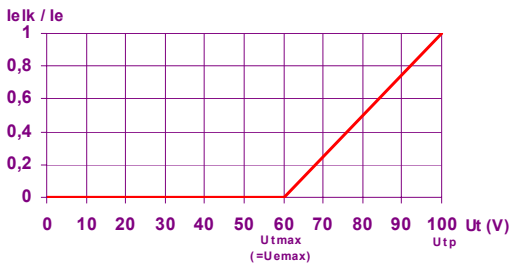
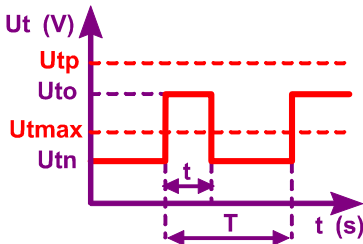
PROTECTION	Leakage current (Ielk) vs DC voltage (Ut)	Absolute limits
		
	<p>Ielk : Leakage current of the relay Ie : User load nominal current Utp : Relay max. non repetitive peak voltage</p>	<p>Utmax : Max. nominal voltage of the relay Uto : Possible overvoltage above Utmax Utn = Ue : User DC power supply voltage</p> <p>t : Overvoltage duration T : Time between 2 overvoltage</p>

Uto < Utp

$$t_{max} = \frac{0.75}{(Uto - Ut_{max}) \times Ie}$$

$$P_{(protection)} = 1W_{max}$$

$$\Rightarrow \frac{(Uto - Ut_{max}) \times Ie \times t}{T} \leq 1$$



TIME CHARACTERISTICS

Fig. 4

TIME DIAGRAMS

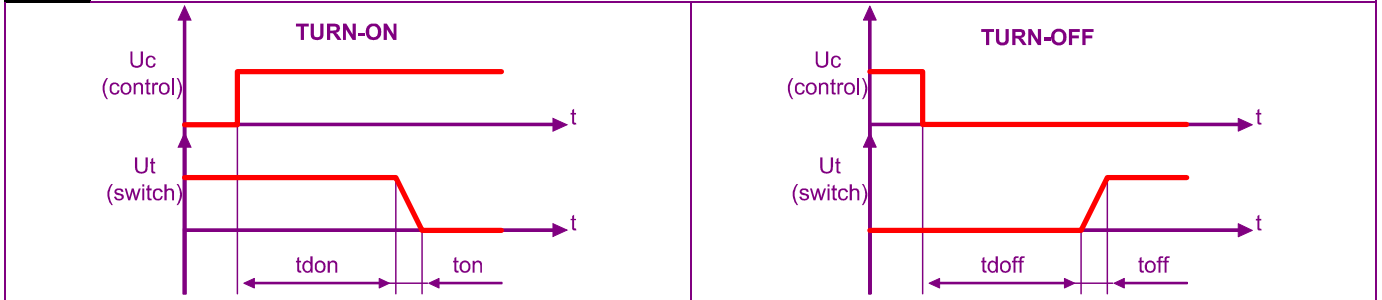

TIME CHARACT.	CHARACTERISTIC	LABEL	VALUE	INFO.
	Turn on time	ton	20µs	
	Turn on delay	tdon	20µs	
	Turn off time	toff	20µs	
	Turn off delay	tdoff	20µs	
	Max. On-Off frequency	F_(on-off)	>1000Hz (for high frequency, take 2 x Ie to calculate the heatsink; the protections must be chosen carefully)	Refer to the instruction sheet

GENERAL INFORMATION

CONNECTIONS	Connections		Power	Control	
	Screwdriver advised		POZIDRIV2		
	Min and max tightening torque		2 N.m	1.2 N.m	
	Insulated crimp terminals (round tabs, eyelet type)		M5	M4	
MISC.	Display		Green LED (indicates relay has switched ON)		
	Housing		UL94V0		
	Mounting		2 screws (M4x12mm ; tightening = 1.2N.m)		See mounting sheet
	Noise level		None		
	Weight		80g		

STANDARDS

GENERAL	Standards		IEC60947-1	
	Protection level		IP20	
	Protection against direct touch		Yes	
	CE marking		Yes	
	UL, cULUS and VDE approvals		Pending	

E.M.C. IMMUNITY	TYPE OF TEST	STANDARD	LEVEL	EFFECT
	E.S.D. (Electrostatic discharges)	EN61000-4-2	Pending	?
	Radiated electromagnetic fields	EN61000-4-3	Pending	?
	Fast transients bursts	EN61000-4-4	Pending	?
	Electric chocks	EN61000-4-5	Pending	?
Voltage drop	EN61000-4-11	-		

E.M.C. EMISSION	Radiated and conducted disturbances	NFEN55011	Pending	
-----------------	-------------------------------------	-----------	---------	--

CHARACTERISTIC CURVES

Fig. 5 INPUT CHARACTERISTIC

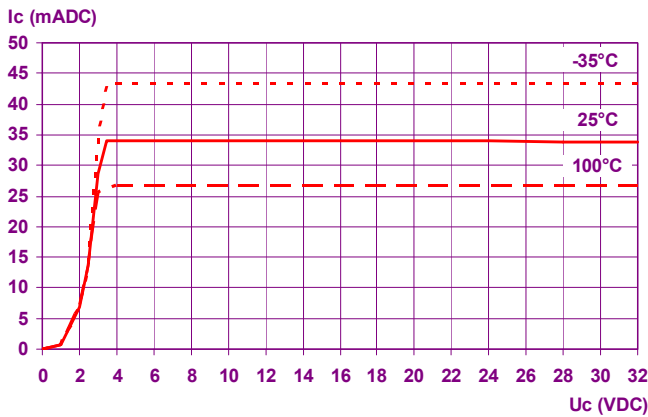

Fig. 6 ON RESISTANCE VS JUNCTION TEMPERATURE

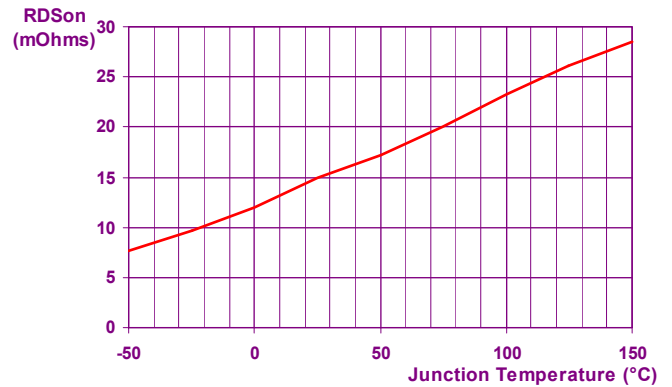

Fig. 7 POWER DISSIPATED AND LOAD CURRENT LIMIT VS TEMPERATURE

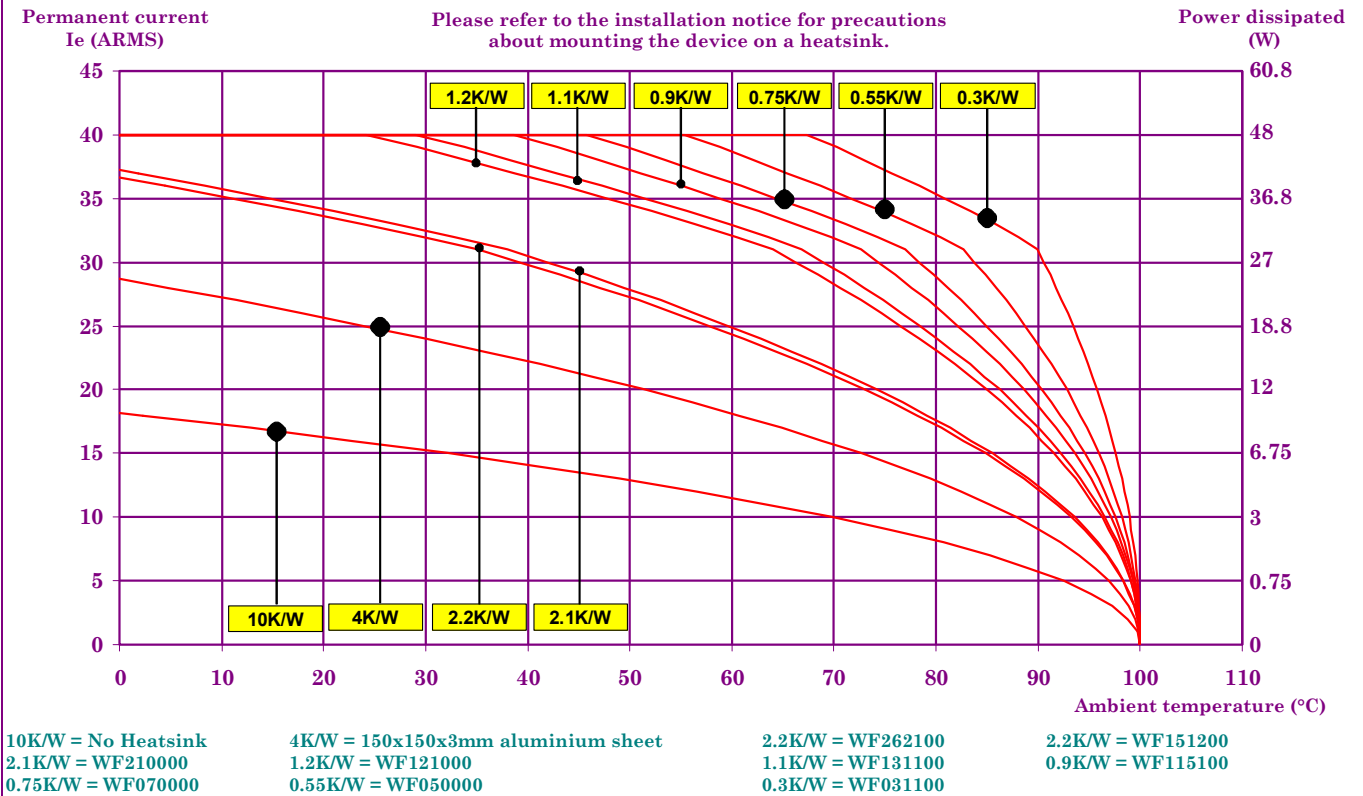
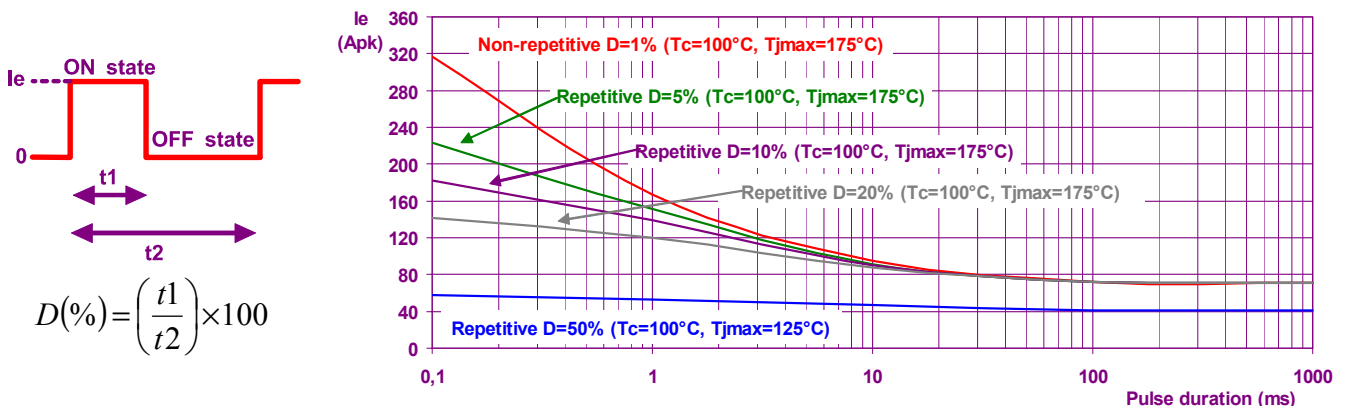

Fig. 8 PEAK OVERLOAD CURRENT vs. PULSE DURATION CHARACTERISTIC





DIMENSIONS AND ACCESSORIES

Fig. 9

DIMENSIONS (mm)

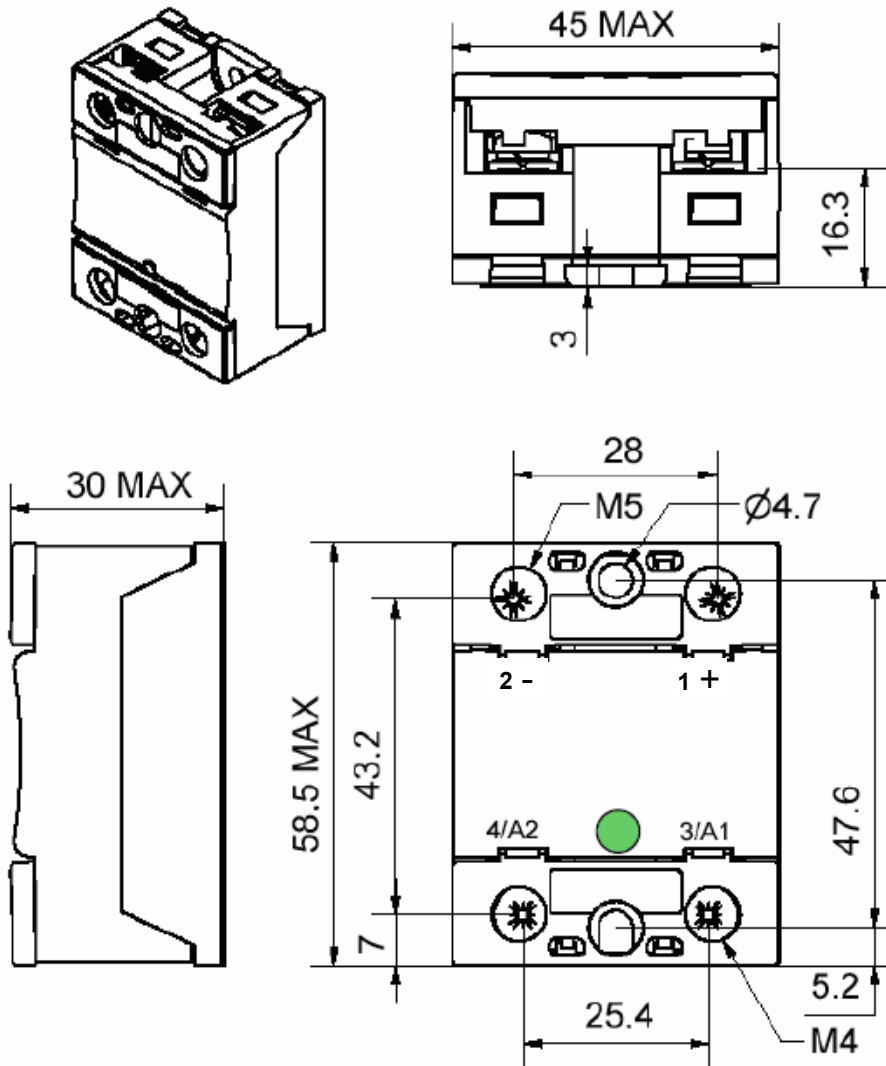

Fig. 10

ACCESSORIES

FASTON : Please contact us



ISO 9001
N° 1993/1106a

ASSOCIATION
FRANÇAISE POUR
L'ASSURANCE DE
LA QUALITÉ