

DIGITAL THREE PHASE ANGLE CONTROLLER

- ▶ Allows to set the voltage applied to different sort of loads with 3 wires, 4 wires or inside the delta wiring:
 - ▶ Resistive (Bulbs, UV and IR lamps, ovens, ...),
 - ▶ Inductive (inductors, transformers, ...),
 - ▶ Motor (motorfan speed control (60 to 100% from the nominal speed),
 - ▶ Rectified (power supplies, ...).
- ▶ Small housing, easy and ready to use.
- ▶ Large mains frequency and voltage range.
- ▶ Fully optoisolated full cycle three phase phase angle controller (balanced currents, less harmonics, ...)
- ▶ Dynamic control voltage range according to the power factor of the load.
- ▶ Softstart and softstop functions (increase lifetime expectancy of the load).
- ▶ Adjustable filter regarding fast input voltage changes (ramps).
- ▶ Motor softstarting functions to control its speed within the stable area.
- ▶ Input-output transfer characteristic linearization function (resistive load).
- ▶ Diagnostic features : Status given on LED and AC/DC switches.

SVTA4684

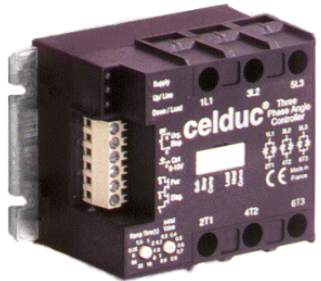

Proportional analog current control input

4-20mA

200->480VAC

50A(95A) AC51

Mains Voltage	Mains Frequency	Max AC-51 Current	Max AC-53a Current	Control Input	Status Outputs	In / Out Insulation	Wire Size	Dimensions (WxHxD)	Weight
200 to 480VAC	40 to 65Hz	50A (95A) (with heatsink)	22.5A (with heatsink)	4-20mADC	0 to 24VDC 1A AC/DC	4kV	In=2.5mm ² Out=10mm ²	100x78x56.5 (mm)	500g

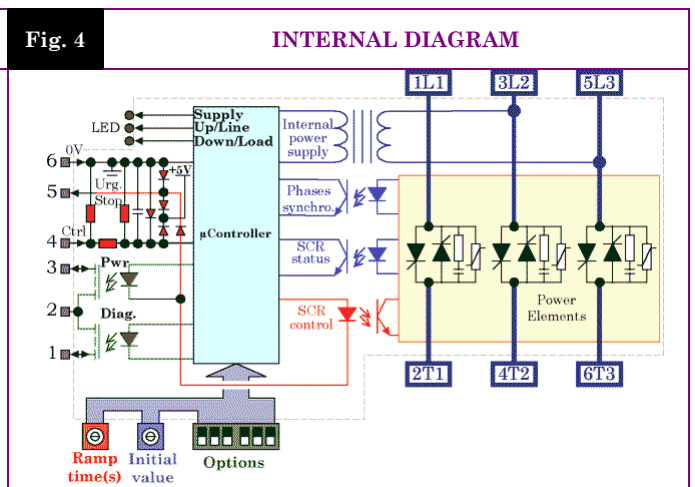
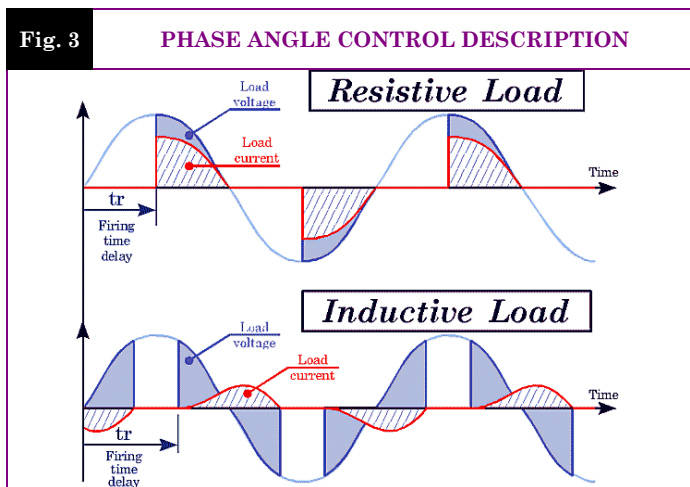
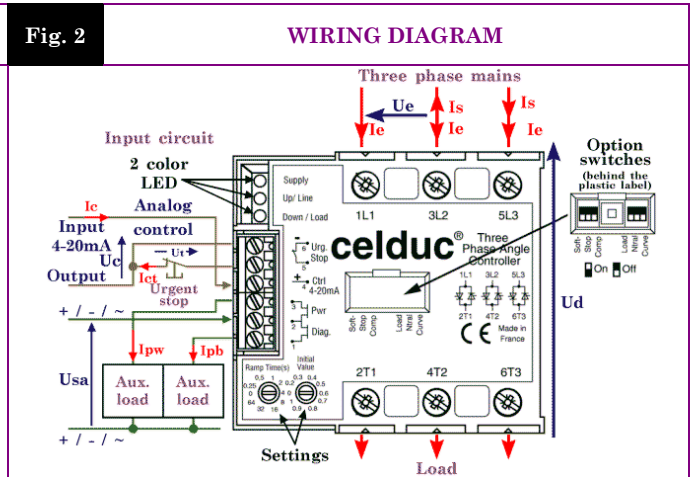
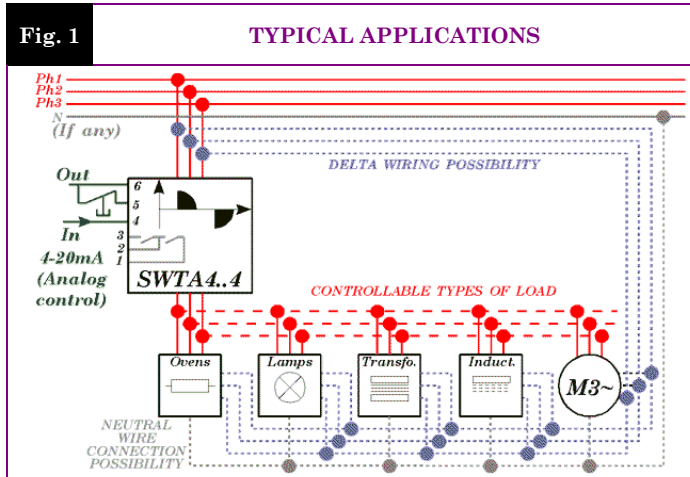

Proud to serve you

SETTINGS

SETTINGS AND OPTIONS	Label	“Ramp Time (s)”	“Initial Value”	“Soft Stop”	“Comp”	“Load”	“Ntrl”	“Curve”
	Description							
	Function	Ramp up time (Softstart and smooth transients)	Initial load voltage (footstep)	Ramp down time	Allows to adapt the control signal range whatever the power factor of the load	Ask the unit to make a softstart up to the max. before analog control.	Tells the unit the load star point is connected to the mains neutral	Tells the unit what kind of in-out response to use (angle or RMS voltage linearity)
	Setting possibilities	Ts= 0 to 64s	Vi=0 to 100%	0 x ts =	On (Up)	On (Up)	On (Up)	On (Up)
	White squares = buttons Example : = all switches down (OFF) (factory setting)			0,5 x ts =	Inductive load	Motor	Star wiring with neutral (4 wires)	RMS voltage control
ts =				Off (Down)	Off (Down)	Off (Down)	Off (Down)	
2 x ts =				Resistive load	Other loads than motors	Delta or star without neutral	Phase angle control	

INPUT CHARACTERISTICS

INPUT CIRCUIT	CHARACTERISTIC	LABEL	VALUE		INFO.
	Labels		“4-20mA”	“Urg. Stop”	
	Function		Analog control input	Stop the thyristor controls	
	Control type		DC control current	Opening the connection between 5 & 6	
	Terminals		4 & 6	5 & 6	
	Control current range	Ic	4-20mA	-	
	Release and control threshold current	Icsmin	4.5mA	-	
	Full power threshold control current	Icsmax	9.5mA	-	
	Max. input voltage	Ucmax	30VDC	6VDC	
	Max. reverse voltage	-Ucmax	30VDC	6VDC	
Release voltage	Ut		>1,5V		
Input impedance	Re	250Ω	-	See fig. 5	
Current to switch	Ict	-	20mADC	Ict=f(Ut)	

STATUS OUTPUTS	Labels		“Diag. “	“Pwr”	
	Terminals		1 & 2	2 & 3	
	Function		Indicates a problem detected in the circuit configuration	Indicates the load is supplied	
	Nominal operating voltage	Usan	24VAC/DC		
	Operating voltage range	Usa	0->28VAC/DC		
	Max. peak voltage	Usap	60V		
	Overvoltage protection		Built-in 25V size7 varistors		
	Minimum load current	Ipw/Ipb	0A		
	Maximum load current	Ipw/Ipb	1A AC/DC		See fig. 6
	Maximum overload current	Ipw/Ipb	2.4A AC/DC		@100ms 10% of the cycle
On and off state switch resistance	Ron / Roff	500mΩ / 100MΩ		See fig. 6	
On and off time delay	Ton / Toff	0.5ms / 2ms			

OUTPUT CHARACTERISTICS

POWER CIRCUIT	CHARACTERISTIC	LABEL	VALUE			INFO.
	Mains voltage range	Ue	200 -> 480VAC			
	Non-repetitive peak voltage	Uep	1200V			
	Oversvoltage protection	VDR	Built-in 510V size 14 varistors			
	Maximum nominal currents <small>Nota : Wire cross section limited to 10mm² (50A) by the terminals</small>	Ie	Resistive Ithmax AC51	Motor Iemax AC53a	Motor Ie AC53a	See fig. 7 for limits Values with heatsink Delta wiring : See installation manual
			50A (95A)	22.5A	16A	
	Maximum line currents in delta wiring	ILine	87A (165A)	39A	22.5A	
	Max motor power	Pe	11kW @400VAC			
	Non-repetitive peak overload current (1 cycle of 10ms)	ITSM	1500A			See fig. 8
	Melting limit for choosing the protective fuses	I ^t	11000A ² s			@10ms
	Minimum load current	Iemin	100mA			
	Maximum leakage current	Ielk	7mA			@400VAC 50Hz
	Power factor	Pf	0->1			
	Mains frequency range	F	40->65Hz			
	Max. off-state voltage rise	dv/dt	500V/μs			
	Protection against fast voltage transients		Buit-in RC network			
	Max. current rise	di/dt	50A/μs			
	On-state voltage drop	Ud	1.4V			@Ith
	Resistive part of the voltage drop	rt	3.5mΩ			@125°C
	Potential part of the voltage drop	Vto	0.9V			@125°C
	Maximum junction temperature	Tjmax	125°C			
	Junction/case thermal resistance per power element	Rthjc	0.3K/W			Total = 3 power elements
	Case heatsink thermal resistance	Rthcs	-			
	Built-in heatsink thermal resistance vertically mounted	Rthra	4K/W			@ΔTra=60°C
Heatsink thermal time constant	Tthra	15min			@ΔTra=60°C	
Inputs/power outputs insulation voltage	Uimp	4kV				
Input/status outputs insulation voltage	Uied	2.5kV				
Inputs/case insulation voltage	Uimp	4kV				
Status outputs/case insulation voltage	Uimp	4kV				
Isolation resistance	Rio	1GΩ				
Isolation capacitance	Cio	<8pF				
Storage ambient temperature	Tstg	-40->+100°C				
Operating ambient temperature	Tamb	-40->+90°C			See fig. 7	
Max. case temperature	Tc	100°C				

INTERNAL POWER SUPPLY

INTERNAL POWER SUPPLY	CHARACTERISTIC	LABEL	VALUE	INFO.
	Terminals		3L2 & 5L3	
	Mains voltage range	Ue	200->480VAC	
	Consumption	Is	1mA typical	
	Mains frequency range	F	40-65Hz	
	Turn-on time	tm	100ms	

GENERAL INFORMATION

CONNEC- TIONS	Connections		Power	Input terminal block	
	Screwdriver advised		Posidriv 2 or 0.8 x 5.5mm	0.8 x 2mm	
	Min and max tightening torque		1.8->3N.m		
	Number and cross section of the wires		2 x 1.5->6mm ² (10mm ² without ferrule)	1 x 2.5mm ²	
	Screwdriver for settings		0.8 x 2mm		

MISC.	Housing		UL94V0	
	Mounting		Omega DIN rail (DIN50022) or screwed	
	Noise level		Low audible vibrations	
	Weight		500g	

STANDARDS

GENERAL	Standards		EN60947-4-2 & EN60947-4-3	
	Protection level		IP2L0	
	Protection against direct touch		Accordin to V.D.E. 160 part 100 : Back hand and finger safety	
	CE marking		Yes	
	UL, cULUS and VDE approvals		Pending	

E.M.C. IMMUNITY	TYPE OF TEST	STANDARD	LEVEL	EFFECT
	E.S.D. (Electrostatic discharges)	EN61000-4-2	8kV (air) 4kV (touch)	No effect
	Radiated electromagnetic fields	EN61000-4-3	10V/m	No effect
	Fast transients bursts	EN61000-4-4	2kV direct coupling on the power side 2kV coupling by clamp on the input side	No effect
	Electric chocks	EN61000-4-5	1kV direct coupling differential mode (input and output) 2kV direct coupling common mode (input and output)	No effect
	Voltage drop	EN61000-4-11	-	

E.M.C. EMISSION	Disturbances	STANDARD	LEVEL	EFFECT
	Radiated and conducted disturbances	NFEN55011		<p>The conducted or radiated disturbances generated by solid state relays depend on the wiring and load configuration.</p> <p>The test method recommended by the European standards and concerning electromagnetic compatibility leading to results far from reality, we decided to advise our customer in order to adapt their filtering scheme to their application.</p> <p>Please refer to the SVTA – SWTA installation manual.</p>

CHARACTERISTIC CURVES

Fig. 5 CONTROL INPUT CHARACTERISTIC

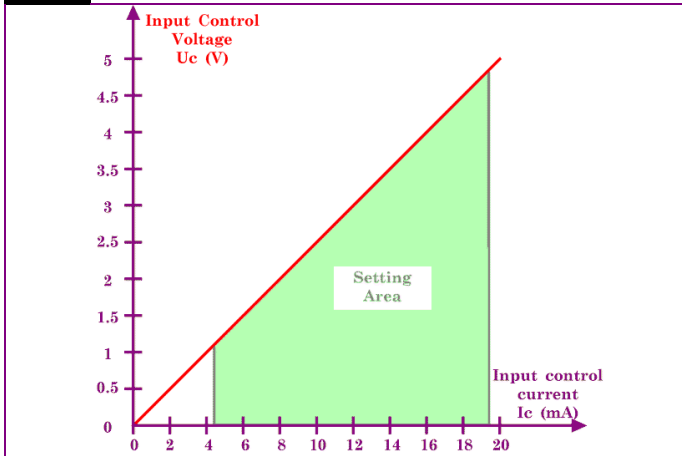

Fig. 6 STATUS SWITCH CURRENT AND ON RESISTANCE VS TEMPERATURE

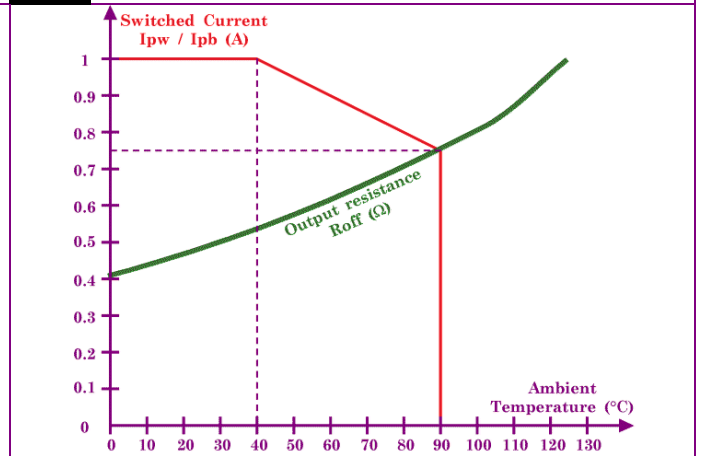

Fig. 7 POWER DISSIPATED AND LOAD CURRENT LIMIT VS TEMPERATURE

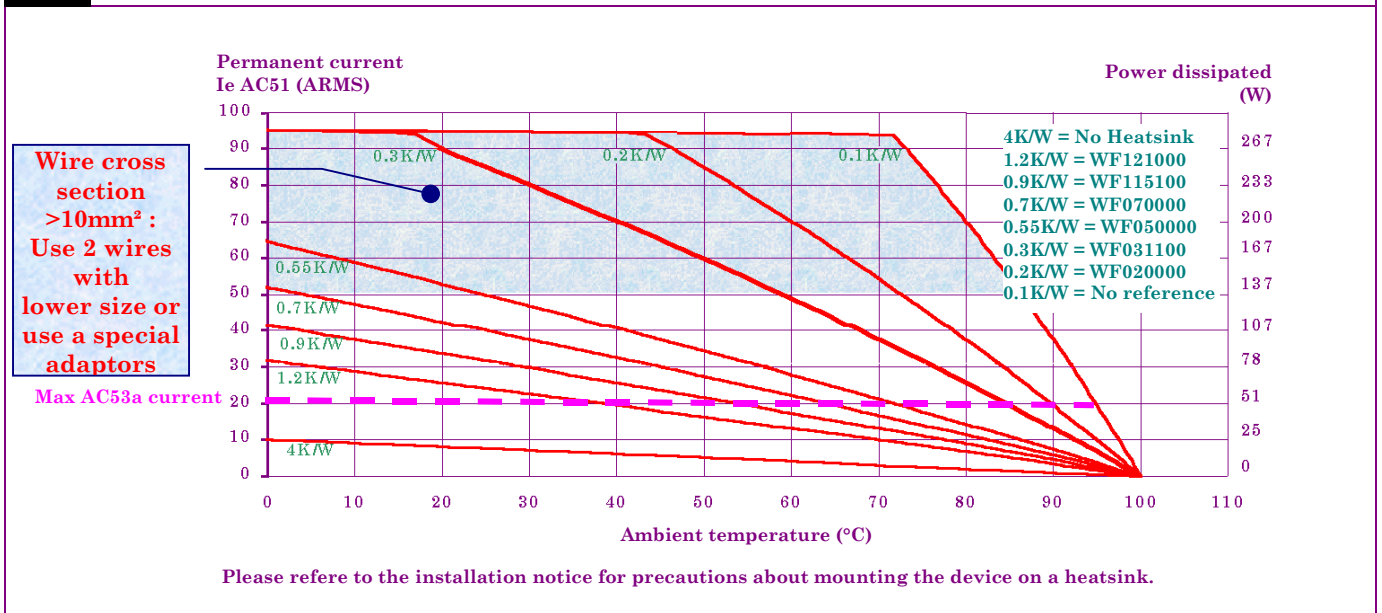
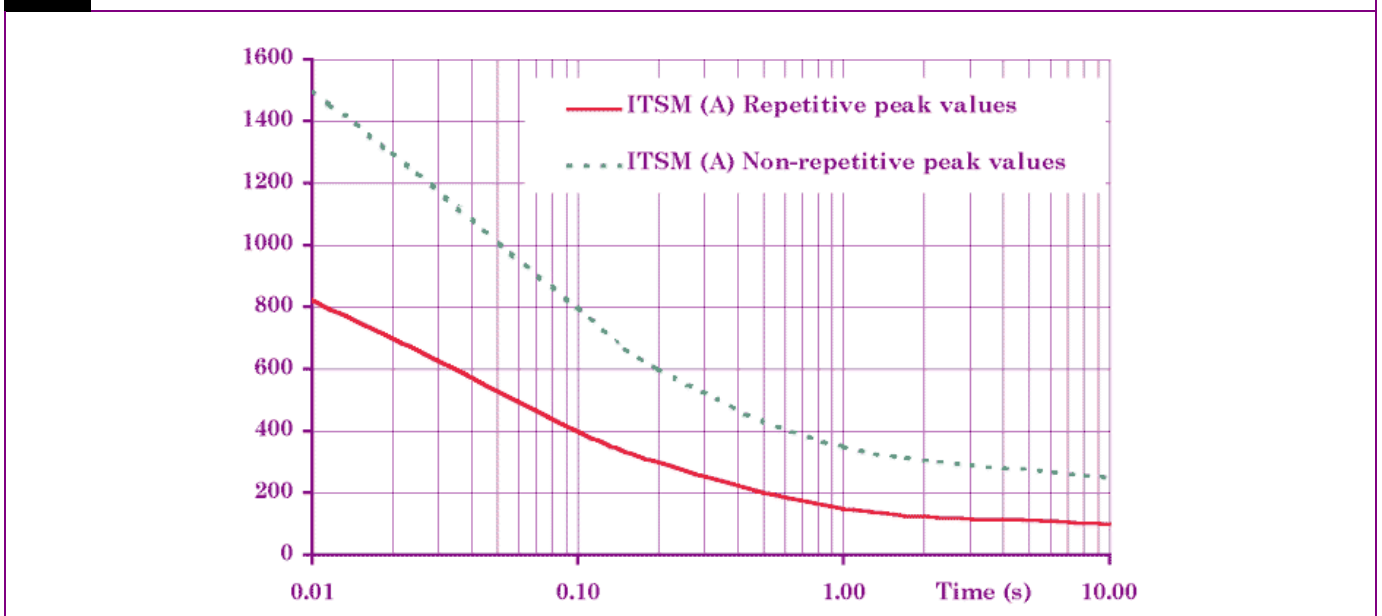

Fig. 8 CURRENT OVERLOAD CHARACTERISTIC (ITSM PER POWER ELEMENT)



DIMENSIONS AND ACCESSORIES

Fig. 9

DIMENSIONS

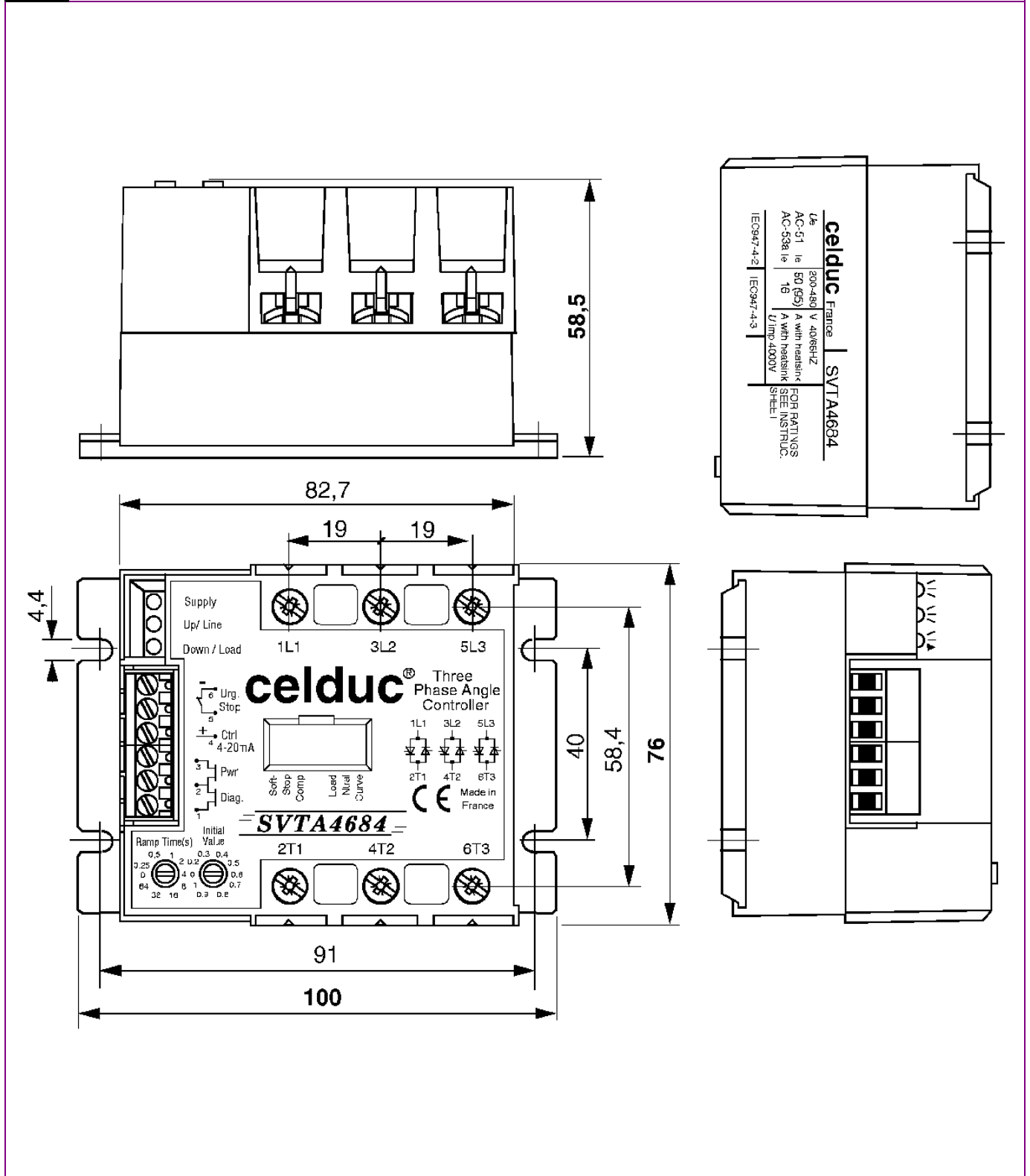

ISO 9001
N° 1993/1106a

ASSOCIATION
FRANÇAISE POUR
L'ASSURANCE DE
LA QUALITÉ

SVTA-SWTA DIAGNOSTIC

NORMAL OPERATION

LED DISPLAY			OUTPUTS		LOAD	COMMENTS
Supply	Line Up	Load Down	Pwr	Diag.		
ANALOG INPUT VOLTAGE BELOW THE MINIMUM CONTROL VOLTAGE THRESHOLD						
					OFF	DIAGNOSTIC Phase presence = OK ; Phase voltage = OK ; Phase frequency = OK LEDs blinking sequence indicates mains phase rotation is direct Load connected Analog input voltage below the minimum control voltage threshold (0.3V (0-10V) ; 4mA (4-20mA) ; 0.15V (0-5V / potentiometer))
					OFF	DIAGNOSTIC Phase presence = OK ; Phase voltage = OK ; Phase frequency = OK LEDs blinking sequence indicates mains phase rotation is reverse Load connected Analog input voltage below the minimum control voltage threshold (0.3V (0-10V) ; 4mA (4-20mA) ; 0.15V (0-5V / potentiometer))
ANALOG INPUT VOLTAGE ABOVE THE MINIMUM CONTROL VOLTAGE THRESHOLD						
					ON	Indicates the voltage at the analog input or the voltage ramp set by the user (Time ramp (s)) is increasing.
					ON	Indicates the voltage at the analog input exceeds the maximum full power threshold voltage (9.7V (0-10V);19.7mA (4-20mA);4.9V (0-5V / potentiometer))
					ON	Indicates the voltage at the analog input or the voltage ramp set by the user (soft-stop) is decreasing.
					ON	Stable analog input voltage or voltage ramps finished (if used) NOTA : A fast UP/DOWN LEDs blinking can occur

ABNORMAL OPERATION

LED DISPLAY			OUTPUTS		LOAD	POSSIBLE CAUSE	SOLUTION
Supply	Line Up	Load Down	Pwr	Diag.			
WHATEVER IS THE VOLTAGE VALUE AT THE ANALOG INPUT							
					OFF	Mains is missing or it is connected on the motor side (2T1, 4T2, 6T3) of the device, instead of the mains side (1L1, 3L2, 5L3)	Check the power side wiring
					OFF	Mains voltage too low	Check phase to phase voltage between 3L2 and 5L3
					OFF	1 or 2 phase(s) missing, Mains frequency out of range, Too many disturbances	Check the phases
					OFF	Microcontroller malfunction or too many problems at the same time	Disconnect the device from the mains for a while and check the wiring
					OFF	Load connection missing, Shorted thyristor (s)	Check load connections and measure the power element resistance (should be several 100kOhms)
					OFF	A problem on the main occurred (e.g. phase missing) and now it is OK but analog input voltage is present	Remove the analog input voltage for a while
					OFF	A problem on the load occurred (e.g. temporary disconnection) and now it is OK but analog input voltage is present	Remove the analog input voltage for a while
					OFF	Factory diagnostic	Consult us
ANALOG INPUT VOLTAGE ABOVE THE MINIMUM CONTROL VOLTAGE THRESHOLD							
					OFF	Power elements can not turn on	Check connection between 5 and 6 of the control terminal block. Check the load current is above the minimum specified
					ON	1 or 2 phase(s) missing, Mains frequency out of range, Too many disturbances	Check the phases

LEGENDE

OFF	GREEN	RED	BLINKING OFF/GREEN	BLINKING OFF/RED

IMPORTANT INFORMATION CONCERNING THE DIAGNOSTIC

- 1- The device makes a complete diagnostic (mains, load and itself) as soon as the mains voltage is sufficient
- 2- The device checks only the presence of phases when the analog input voltage is above the minimum control threshold, during the ramps (softstart and softstop) and when it is full on (the power elements are tested only when analog control voltage is below the minimum control voltage threshold).
- 3- The control overrides the diagnostic.
 - If a problem occurs during the control period, the device will try to go on driving the load according the analog input voltage. If the problem goes on, it will be if possible indicated to the user according the diagnostic table.
 - If a problem occurs during the softstopping period, the device will stop immediately in order to reach the off state diagnostic period.

PRELIMINARY 22/01/04