

Dissipateur Thermique avec adaptateur DIN Heatsink with DIN rail adaptor

WF311100

R_{th} : 3K/W
en air calme
(@20W) sans ventilation.

*in air calm (@20W)
without ventilation*

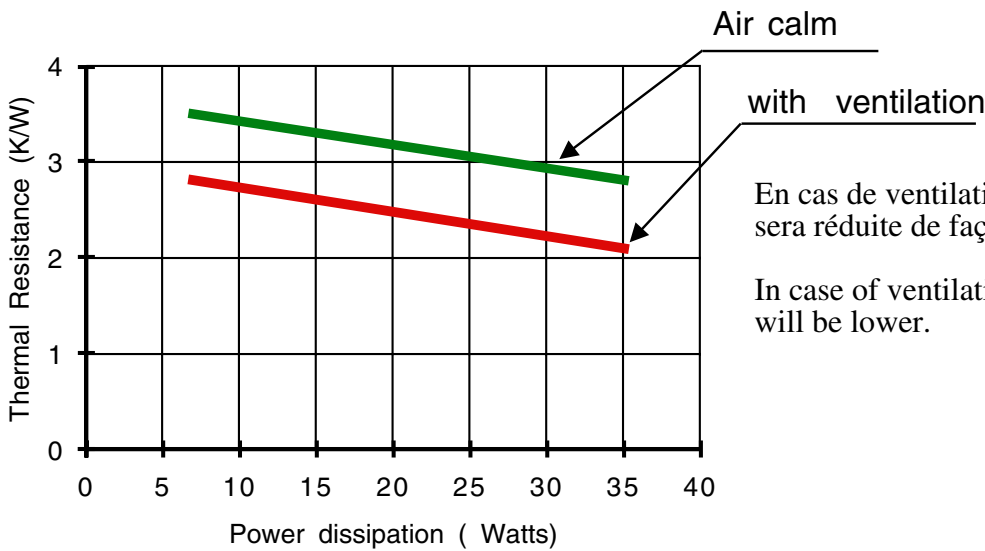
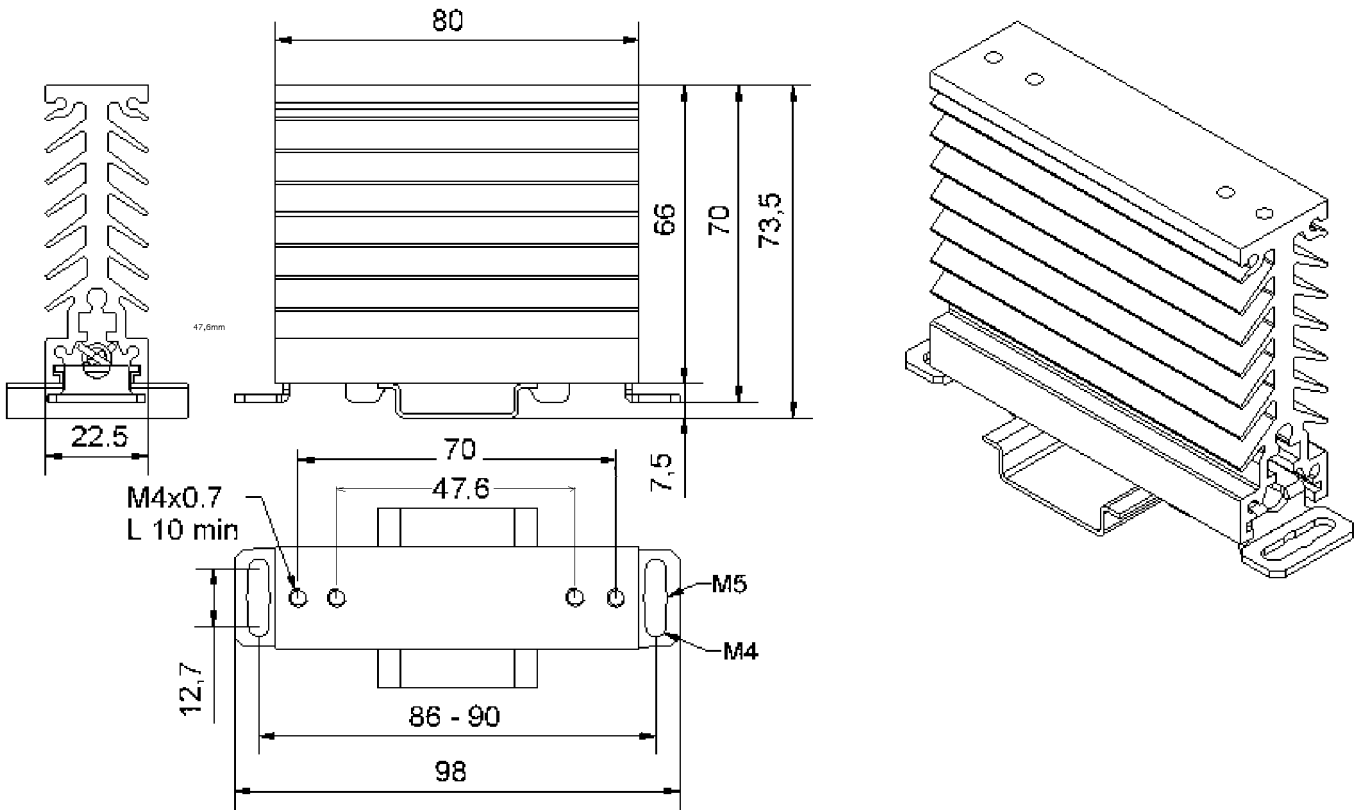

En cas de ventilation, la résistance thermique sera réduite de façon significative.

In case of ventilation, the thermal resistance will be lower.

Proud to serve you

celduc®
r e l a i s