

74HC4067; 74HCT4067

16-channel analog multiplexer/demultiplexer

Rev. 5 — 13 December 2011

Product data sheet

1. General description

The 74HC4067; 74HCT4067 is a high-speed Si-gate CMOS device and is pin compatible with the HEF4067B. The device is specified in compliance with JEDEC standard no. 7A.

The 74HC4067; 74HCT4067 is a 16-channel analog multiplexer/demultiplexer with four address inputs (S0 to S3), an active-LOW enable input (\overline{E}), sixteen independent inputs/outputs (Y0 to Y15) and a common input/output (Z).

The 74HC4067; 74HCT4067 contains sixteen bidirectional analog switches, each with one side connected to an independent input/output (Y0 to Y15) and the other side connected to a common input/output (Z).

With pin \overline{E} = LOW, one of the sixteen switches is selected by pins S0 to S3 (low impedance ON-state). All unselected switches are in the high-impedance OFF-state. With pin \overline{E} = HIGH, all switches are in the high-impedance OFF-state, independent of pins S0 to S3.

The analog inputs/outputs (Y0 to Y15, and Z) can swing between V_{CC} as a positive limit and GND as a negative limit. V_{CC} to GND may not exceed 10 V.

2. Features and benefits

- Low ON resistance:
 - ◆ 80 Ω (typical) at $V_{CC} = 4.5$ V
 - ◆ 70 Ω (typical) at $V_{CC} = 6.0$ V
 - ◆ 60 Ω (typical) at $V_{CC} = 9.0$ V
- Typical 'break before make' built-in

3. Applications

- Analog multiplexing and demultiplexing
- Digital multiplexing and demultiplexing
- Signal gating



4. Ordering information

Table 1. Ordering information

Type number	Package			
	Temperature range	Name	Description	Version
74HC4067				
74HC4067N	−40 °C to +125 °C	DIP24	plastic dual in-line package; 24 leads (600 mil); reverse bending	SOT101-1
74HC4067D	−40 °C to +125 °C	SO24	plastic small outline package; 24 leads; body width 7.5 mm	SOT137-1
74HC4067DB	−40 °C to +125 °C	SSOP24	plastic shrink small outline package; 24 leads; body width 5.3 mm	SOT340-1
74HC4067PW	−40 °C to +125 °C	TSSOP24	plastic thin shrink small outline package; 24 leads; body width 4.4 mm	SOT355-1
74HC4067BQ	−40 °C to +125 °C	DHVQFN24	plastic dual in-line compatible thermal enhanced very thin quad flat package; no leads; 24 terminals; body 3.5 × 5.5 × 0.85 mm	SOT815-1
74HCT4067				
74HCT4067N	−40 °C to +125 °C	DIP24	plastic dual in-line package; 24 leads (600 mil); reverse bending	SOT101-1
74HCT4067D	−40 °C to +125 °C	SO24	plastic small outline package; 24 leads; body width 7.5 mm	SOT137-1
74HCT4067DB	−40 °C to +125 °C	SSOP24	plastic shrink small outline package; 24 leads; body width 5.3 mm	SOT340-1
74HCT4067PW	−40 °C to +125 °C	TSSOP24	plastic thin shrink small outline package; 24 leads; body width 4.4 mm	SOT355-1
74HCT4067BQ	−40 °C to +125 °C	DHVQFN24	plastic dual in-line compatible thermal enhanced very thin quad flat package; no leads; 24 terminals; body 3.5 × 5.5 × 0.85 mm	SOT815-1

5. Functional diagram

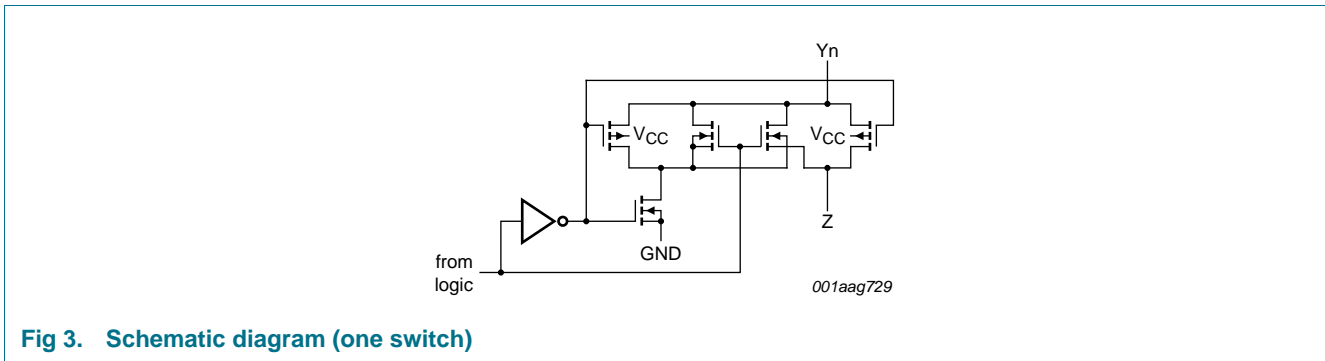
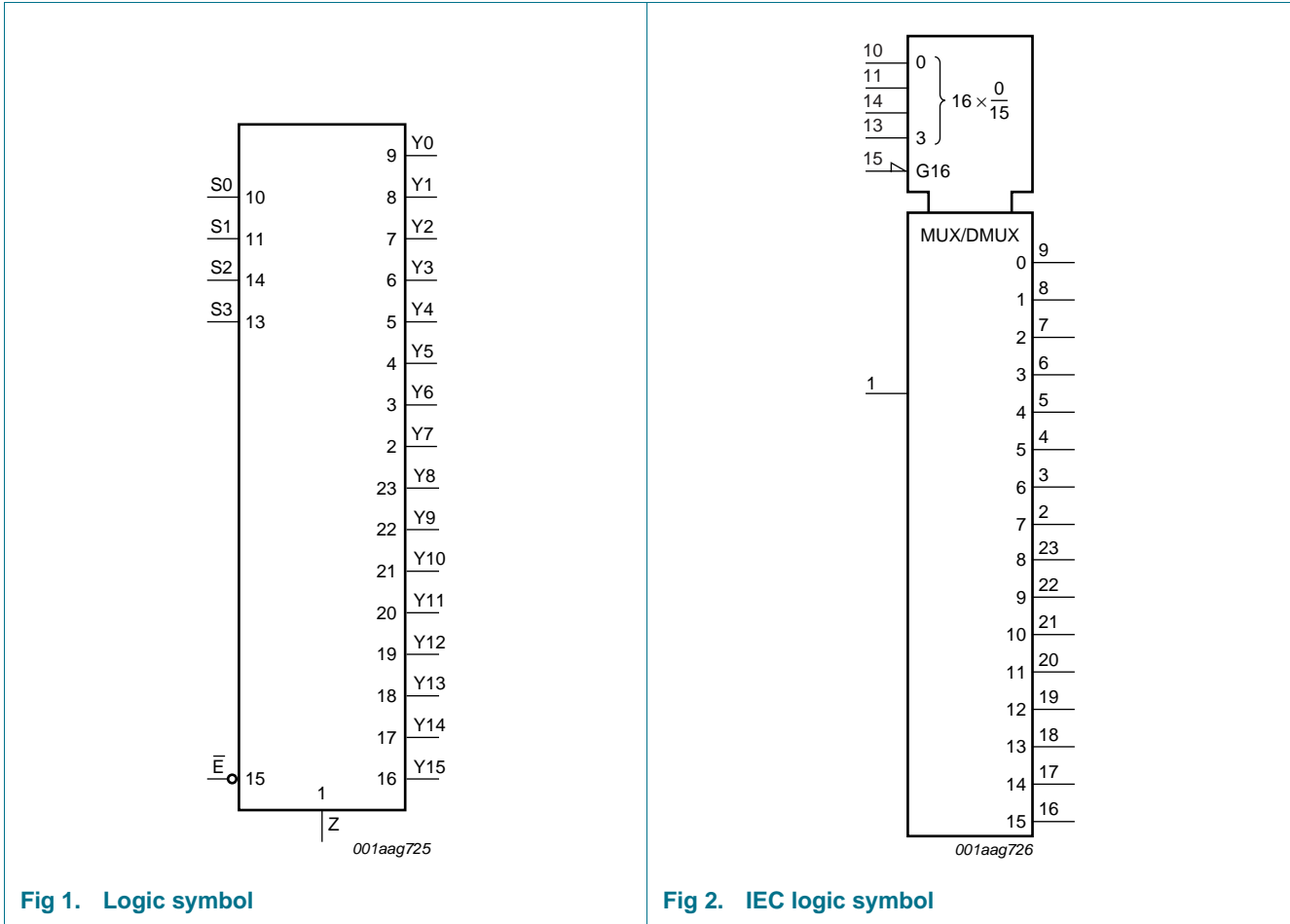

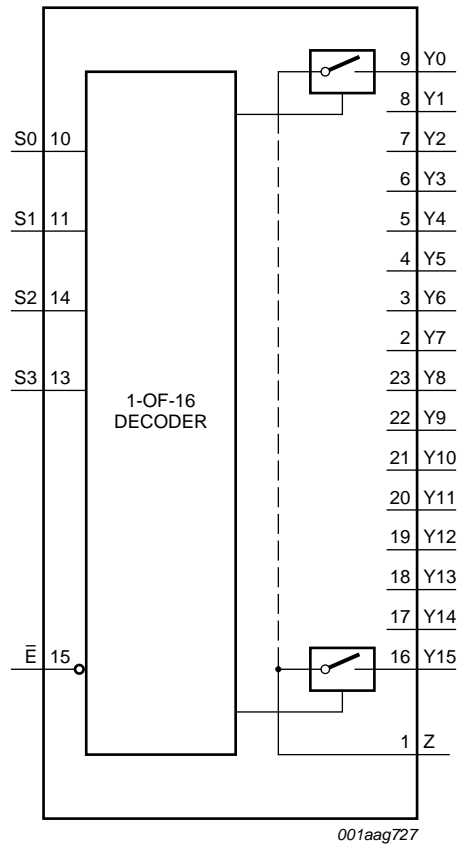

Fig 4. Functional diagram

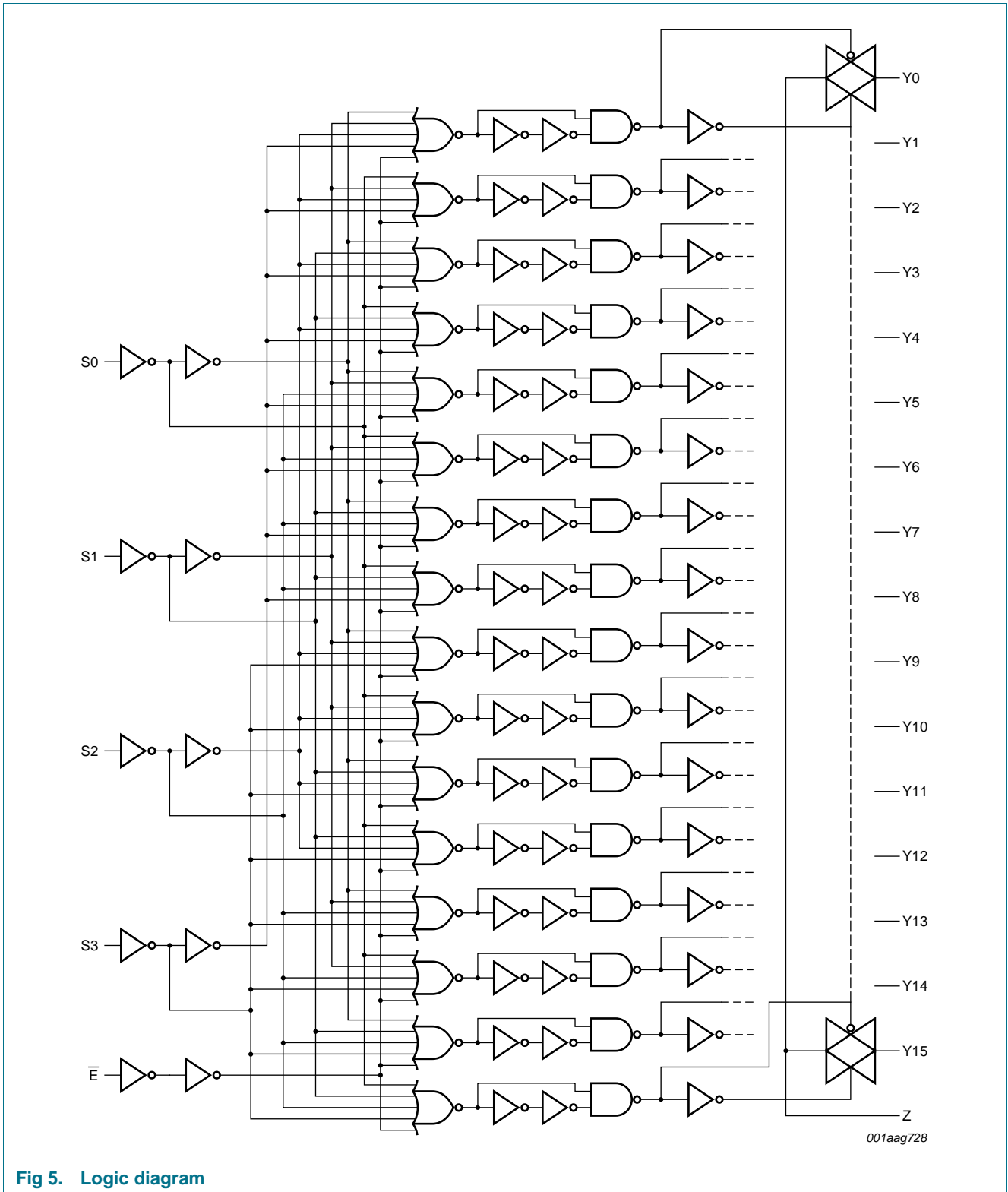
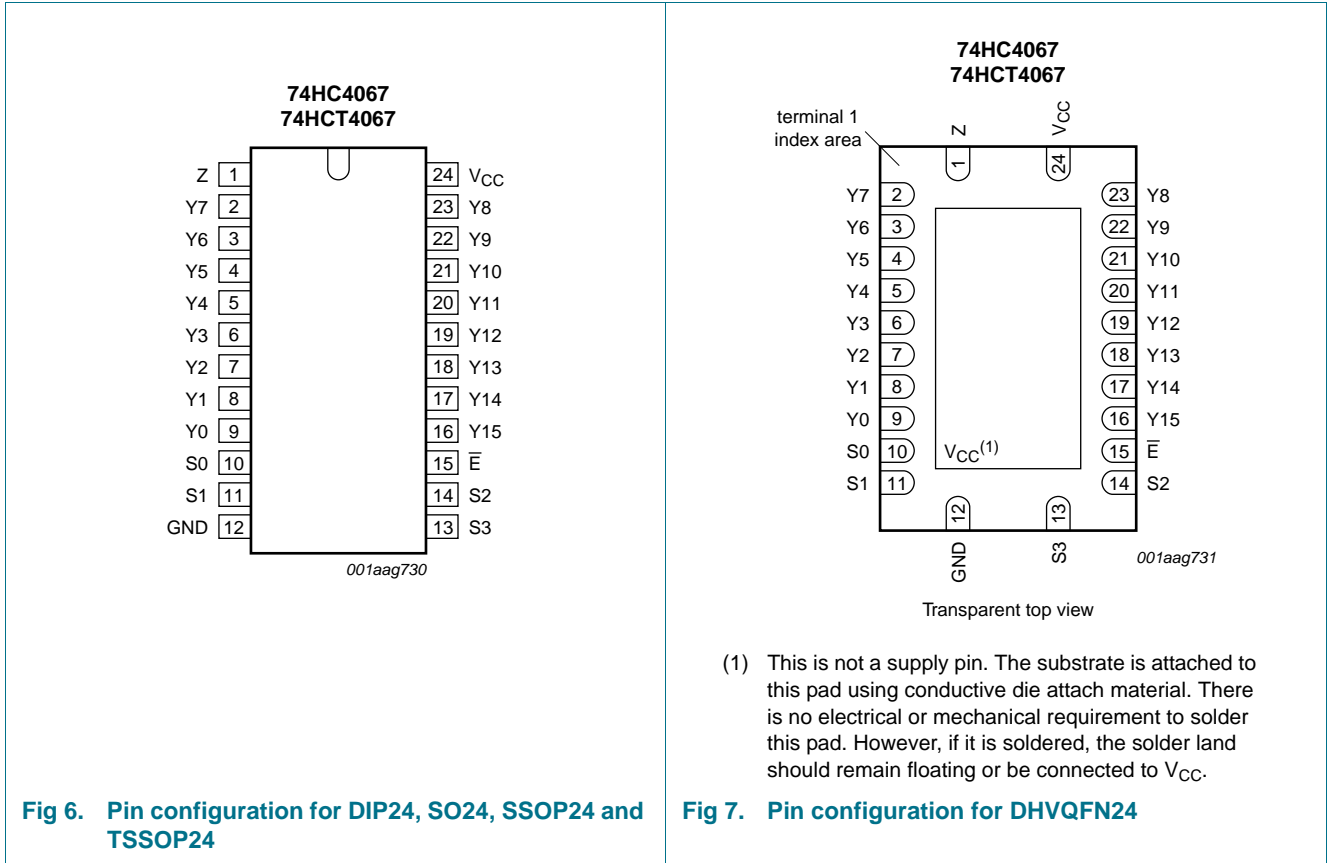

Fig 5. Logic diagram

6. Pinning information

6.1 Pinning



6.2 Pin description

Table 2. Pin description

Symbol	Pin	Description
Z	1	common input or output
Y7, Y6, Y5, Y4, Y3, Y2, Y1, Y0, Y15, Y14, Y13, Y12, Y11, Y10, Y9, Y8	2, 3, 4, 5, 6, 7, 8, 9, 16, 17, 18, 19, 20, 21, 22, 23	independent input or output
S0, S1, S3, S2	10, 11, 13, 14	address input 0
GND	12	ground (0 V)
\bar{E}	15	enable input (active LOW)
V _{CC}	24	supply voltage

7. Functional description

Table 3. Function table^[1]

Inputs					Channel ON
\bar{E}	S3	S2	S1	S0	
L	L	L	L	L	Y0 to Z
L	L	L	L	H	Y1 to Z
L	L	L	H	L	Y2 to Z
L	L	L	H	H	Y3 to Z
L	L	H	L	L	Y4 to Z
L	L	H	L	H	Y5 to Z
L	L	H	H	L	Y6 to Z
L	L	H	H	H	Y7 to Z
L	H	L	L	L	Y8 to Z
L	H	L	L	H	Y9 to Z
L	H	L	H	L	Y10 to Z
L	H	L	H	H	Y11 to Z
L	H	H	L	L	Y12 to Z
L	H	H	L	H	Y13 to Z
L	H	H	H	L	Y14 to Z
L	H	H	H	H	Y15 to Z
H	X	X	X	X	-

[1] H = HIGH voltage level;
L = LOW voltage level;
X = don't care.

8. Limiting values

Table 4. Limiting values

In accordance with the Absolute Maximum Rating System (IEC 60134). Voltages are referenced to GND (ground = 0 V).

Symbol	Parameter	Conditions	Min	Max	Unit
V_{CC}	supply voltage		^[1] -0.5	+11.0	V
I_{IK}	input clamping current	$V_I < -0.5\text{ V}$ or $V_I > V_{CC} + 0.5\text{ V}$	-	±20	mA
I_{SK}	switch clamping current	$V_{SW} < -0.5\text{ V}$ or $V_{SW} > V_{CC} + 0.5\text{ V}$	-	±20	mA
I_{SW}	switch current	$V_{SW} = -0.5\text{ V}$ to $V_{CC} + 0.5\text{ V}$	-	±25	mA
I_{CC}	supply current		-	50	mA
I_{GND}	ground current		-	-50	mA
T_{stg}	storage temperature		-65	+150	°C

Table 4. Limiting values ...continued

In accordance with the Absolute Maximum Rating System (IEC 60134). Voltages are referenced to GND (ground = 0 V).

Symbol	Parameter	Conditions	Min	Max	Unit	
P _{tot}	total power dissipation	T _{amb} = -40 °C to +125 °C				
		DIP24 package	[2]	-	750	mW
		SO24 package	[3]	-	500	mW
		SSOP24 package	[4]	-	500	mW
		TSSOP24 package	[4]	-	500	mW
		DHVQFN24 package	[5]	-	500	mW
P	power dissipation	per switch	-	100	mW	

- [1] To avoid drawing V_{CC} current out of terminal Z, when switch current flows in terminals Y_n, the voltage drop across the bidirectional switch must not exceed 0.4 V. If the switch current flows into terminal Z, no V_{CC} current will flow out of terminals Y_n. In this case there is no limit for the voltage drop across the switch, but the voltages at Y_n and Z may not exceed V_{CC} or GND.
- [2] For DIP24 package: P_{tot} derates linearly with 12 mW/K above 70 °C.
- [3] For SO24 package: P_{tot} derates linearly with 8 mW/K above 70 °C.
- [4] For SSOP24 and TSSOP24 packages: P_{tot} derates linearly with 5.5 mW/K above 60 °C.
- [5] For DHVQFN24 package: P_{tot} derates linearly with 4.5 mW/K above 60 °C.

9. Recommended operating conditions

Table 5. Recommended operating conditions

Symbol	Parameter	Conditions	Min	Typ	Max	Unit
74HC4067						
V _{CC}	supply voltage		2.0	5.0	10.0	V
V _I	input voltage		GND	-	V _{CC}	V
V _{SW}	switch voltage		GND	-	V _{CC}	V
Δt/ΔV	input transition rise and fall rate	V _{CC} = 2.0 V	-	-	625	ns
		V _{CC} = 4.5 V	-	1.67	139	ns
		V _{CC} = 6.0 V	-	-	83	ns
		V _{CC} = 10.0 V	-	-	31	ns
T _{amb}	ambient temperature		-40	+25	+125	°C
74HCT4067						
V _{CC}	supply voltage		4.5	5.0	5.5	V
V _I	input voltage		GND	-	V _{CC}	V
V _{SW}	switch voltage		GND	-	V _{CC}	V
Δt/ΔV	input transition rise and fall rate	V _{CC} = 4.5 V	-	1.67	139	ns
T _{amb}	ambient temperature		-40	+25	+125	°C

10. Static characteristics

Table 6. R_{ON} resistance per switch for types 74HC4067 and 74HCT4067

$V_I = V_{IH}$ or V_{IL} ; for test circuit see [Figure 8](#).

V_{is} is the input voltage at a Yn or Z terminal, whichever is assigned as an input.

V_{os} is the output voltage at a Yn or Z terminal, whichever is assigned as an output.

For 74HC4067: $V_{CC} - GND = 2.0\text{ V}, 4.5\text{ V}, 6.0\text{ V}$ and 9.0 V .

For 74HCT4067: $V_{CC} - GND = 4.5\text{ V}$.

Symbol	Parameter	Conditions	25 °C		-40 °C to +125 °C		Unit	
			Typ	Max	Max (85 °C)	Max (125 °C)		
$R_{ON(peak)}$	ON resistance (peak)	$V_{is} = V_{CC}$ to GND						
		$V_{CC} = 2.0\text{ V}; I_{SW} = 100\ \mu\text{A}$	[1]	-	-	-	Ω	
		$V_{CC} = 4.5\text{ V}; I_{SW} = 1000\ \mu\text{A}$		110	180	225	270	Ω
		$V_{CC} = 6.0\text{ V}; I_{SW} = 1000\ \mu\text{A}$		95	160	200	240	Ω
		$V_{CC} = 9.0\text{ V}; I_{SW} = 1000\ \mu\text{A}$		75	130	165	195	Ω
$R_{ON(rail)}$	ON resistance (rail)	$V_{is} = GND$ or V_{CC}						
		$V_{CC} = 2.0\text{ V}; I_{SW} = 100\ \mu\text{A}$	[1]	150	-	-	-	
		$V_{CC} = 4.5\text{ V}; I_{SW} = 1000\ \mu\text{A}$		90	160	200	240	Ω
		$V_{CC} = 6.0\text{ V}; I_{SW} = 1000\ \mu\text{A}$		80	140	175	210	Ω
		$V_{CC} = 9.0\text{ V}; I_{SW} = 1000\ \mu\text{A}$		70	120	150	180	Ω
ΔR_{ON}	ON resistance mismatch between channels	$V_{is} = V_{CC}$ to GND						
		$V_{CC} = 2.0\text{ V}$	[1]	-	-	-	-	Ω
		$V_{CC} = 4.5\text{ V}$		9	-	-	-	Ω
		$V_{CC} = 6.0\text{ V}$		8	-	-	-	Ω
		$V_{CC} = 9.0\text{ V}$		6	-	-	-	Ω

[1] At supply voltages ($V_{CC} - GND$) approaching 2 V, the analog switch ON resistance becomes extremely non-linear. Therefore it is recommended that these devices be used to transmit digital signals only, when using these supply voltages.

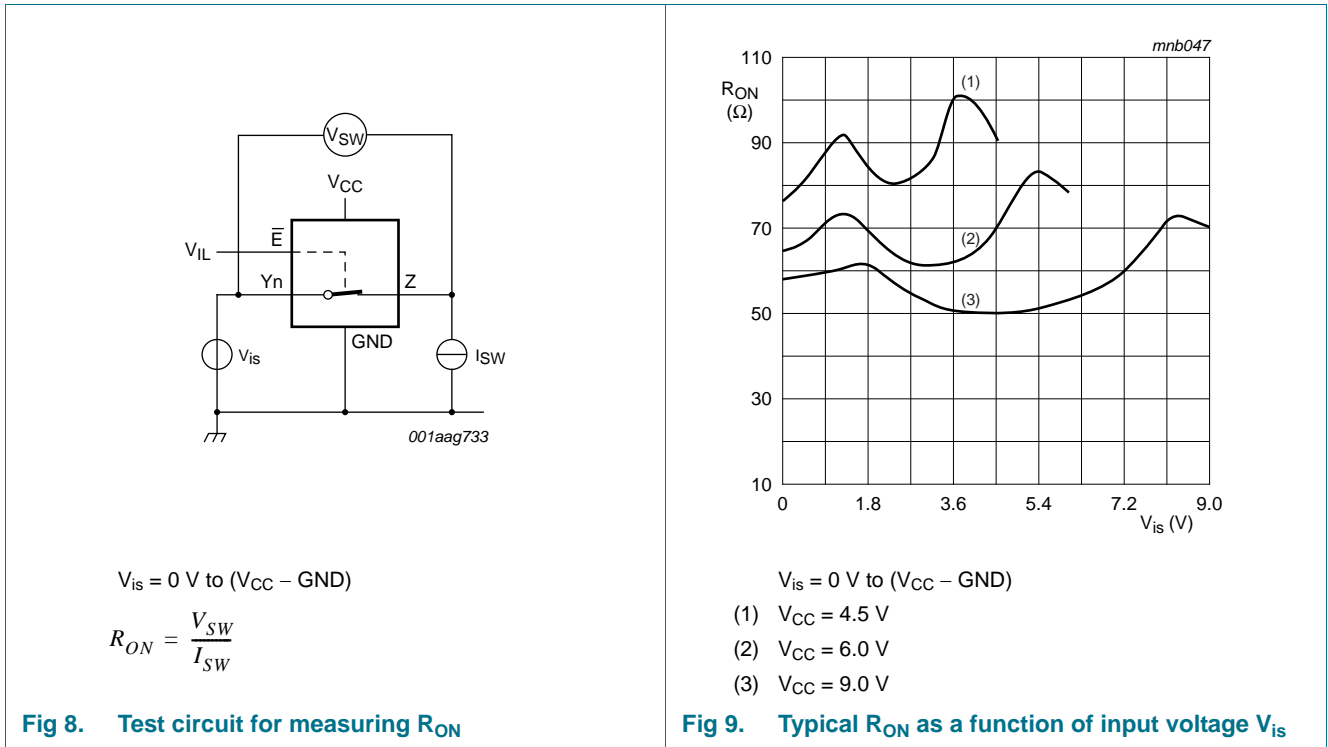

Table 7. Static characteristics 74HC4067

At recommended operating conditions; voltages are referenced to GND (ground = 0 V).
 V_{is} is the input voltage at a Y_n or Z terminal, whichever is assigned as an input.
 V_{os} is the output voltage at a Y_n or Z terminal, whichever is assigned as an output.

Symbol	Parameter	Conditions	Min	Typ	Max	Unit
$T_{amb} = 25 \text{ }^\circ\text{C}$						
V_{IH}	HIGH-level input voltage	$V_{CC} = 2.0 \text{ V}$	1.5	1.2	-	V
		$V_{CC} = 4.5 \text{ V}$	3.15	2.4	-	V
		$V_{CC} = 6.0 \text{ V}$	4.2	3.2	-	V
		$V_{CC} = 9.0 \text{ V}$	6.3	4.7	-	V
V_{IL}	LOW-level input voltage	$V_{CC} = 2.0 \text{ V}$	-	0.8	0.5	V
		$V_{CC} = 4.5 \text{ V}$	-	2.1	1.35	V
		$V_{CC} = 6.0 \text{ V}$	-	2.8	1.80	V
		$V_{CC} = 9.0 \text{ V}$	-	4.3	2.70	V
I_I	input leakage current	$V_I = V_{CC} \text{ or } \text{GND}$				
		$V_{CC} = 6.0 \text{ V}$	-	-	± 0.1	μA
		$V_{CC} = 10.0 \text{ V}$	-	-	± 0.2	μA
$I_{S(OFF)}$	OFF-state leakage current	$V_{CC} = 10.0 \text{ V}; V_I = V_{IH} \text{ or } V_{IL}; V_{SW} = V_{CC} - \text{GND};$ see Figure 10				
		per channel	-	-	± 0.1	μA
		all channels	-	-	± 0.8	μA
$I_{S(ON)}$	ON-state leakage current	$V_{CC} = 10.0 \text{ V}; V_I = V_{IH} \text{ or } V_{IL}; V_{SW} = V_{CC} - \text{GND};$ see Figure 11	-	-	± 0.8	μA

Table 7. Static characteristics 74HC4067 ...continued

At recommended operating conditions; voltages are referenced to GND (ground = 0 V).

V_{is} is the input voltage at a Yn or Z terminal, whichever is assigned as an input.

V_{os} is the output voltage at a Yn or Z terminal, whichever is assigned as an output.

Symbol	Parameter	Conditions	Min	Typ	Max	Unit
I_{CC}	supply current	$V_I = V_{CC}$ or GND; $V_{is} =$ GND or V_{CC} ; $V_{os} = V_{CC}$ or GND				
		$V_{CC} = 6.0$ V	-	-	8.0	μ A
		$V_{CC} = 10.0$ V	-	-	16.0	μ A
C_I	input capacitance		-	3.5	-	pF
$T_{amb} = -40$ °C to $+85$ °C						
V_{IH}	HIGH-level input voltage	$V_{CC} = 2.0$ V	1.5	-	-	V
		$V_{CC} = 4.5$ V	3.15	-	-	V
		$V_{CC} = 6.0$ V	4.2	-	-	V
		$V_{CC} = 9.0$ V	6.3	-	-	V
V_{IL}	LOW-level input voltage	$V_{CC} = 2.0$ V	-	-	0.50	V
		$V_{CC} = 4.5$ V	-	-	1.35	V
		$V_{CC} = 6.0$ V	-	-	1.80	V
		$V_{CC} = 9.0$ V	-	-	2.70	V
I_I	input leakage current	$V_I = V_{CC}$ or GND				
		$V_{CC} = 6.0$ V	-	-	± 1.0	μ A
		$V_{CC} = 10.0$ V	-	-	± 2.0	μ A
$I_{S(OFF)}$	OFF-state leakage current	$V_{CC} = 10.0$ V; $V_I = V_{IH}$ or V_{IL} ; $ V_{SW} = V_{CC} - \text{GND}$; see Figure 10				
		per channel	-	-	± 1.0	μ A
		all channels	-	-	± 8.0	μ A
$I_{S(ON)}$	ON-state leakage current	$V_{CC} = 10.0$ V; $V_I = V_{IH}$ or V_{IL} ; $ V_{SW} = V_{CC} - \text{GND}$; see Figure 11	-	-	± 8.0	μ A
I_{CC}	supply current	$V_I = V_{CC}$ or GND; $V_{is} =$ GND or V_{CC} ; $V_{os} = V_{CC}$ or GND				
		$V_{CC} = 6.0$ V	-	-	80.0	μ A
		$V_{CC} = 10.0$ V	-	-	160	μ A
$T_{amb} = -40$ °C to $+125$ °C						
V_{IH}	HIGH-level input voltage	$V_{CC} = 2.0$ V	1.5	-	-	V
		$V_{CC} = 4.5$ V	3.15	-	-	V
		$V_{CC} = 6.0$ V	4.2	-	-	V
		$V_{CC} = 9.0$ V	6.3	-	-	V
V_{IL}	LOW-level input voltage	$V_{CC} = 2.0$ V	-	-	0.50	V
		$V_{CC} = 4.5$ V	-	-	1.35	V
		$V_{CC} = 6.0$ V	-	-	1.80	V
		$V_{CC} = 9.0$ V	-	-	2.70	V
I_I	input leakage current	$V_I = V_{CC}$ or GND				
		$V_{CC} = 6.0$ V	-	-	± 1.0	μ A
		$V_{CC} = 10.0$ V	-	-	± 2.0	μ A

Table 7. Static characteristics 74HC4067 ...continued

At recommended operating conditions; voltages are referenced to GND (ground = 0 V).

V_{is} is the input voltage at a Yn or Z terminal, whichever is assigned as an input.

V_{os} is the output voltage at a Yn or Z terminal, whichever is assigned as an output.

Symbol	Parameter	Conditions	Min	Typ	Max	Unit
$I_{S(OFF)}$	OFF-state leakage current	$V_{CC} = 10.0\text{ V}$; $V_I = V_{IH}$ or V_{IL} ; $ V_{SW} = V_{CC} - \text{GND}$; see Figure 10				
		per channel	-	-	± 1.0	μA
		all channels	-	-	± 8.0	μA
$I_{S(ON)}$	ON-state leakage current	$V_{CC} = 10.0\text{ V}$; $V_I = V_{IH}$ or V_{IL} ; $ V_{SW} = V_{CC} - \text{GND}$; see Figure 11	-	-	± 8.0	μA
I_{CC}	supply current	$V_I = V_{CC}$ or GND; $V_{is} = \text{GND}$ or V_{CC} ; $V_{os} = V_{CC}$ or GND				
		$V_{CC} = 6.0\text{ V}$	-	-	160	μA
		$V_{CC} = 10.0\text{ V}$	-	-	320	μA

Table 8. Static characteristics 74HCT4067

At recommended operating conditions; voltages are referenced to GND (ground = 0 V).

V_{is} is the input voltage at a Yn or Z terminal, whichever is assigned as an input.

V_{os} is the output voltage at a Yn or Z terminal, whichever is assigned as an output.

Symbol	Parameter	Conditions	Min	Typ	Max	Unit
$T_{amb} = 25\text{ }^\circ\text{C}$						
V_{IH}	HIGH-level input voltage	$V_{CC} = 4.5\text{ V to }5.5\text{ V}$	2.0	1.6	-	V
V_{IL}	LOW-level input voltage	$V_{CC} = 4.5\text{ V to }5.5\text{ V}$	-	1.2	0.8	V
I_I	input leakage current	$V_I = V_{CC}$ or GND; $V_{CC} = 5.5\text{ V}$	-	-	± 0.1	μA
$I_{S(OFF)}$	OFF-state leakage current	$V_{CC} = 5.5\text{ V}$; $V_I = V_{IH}$ or V_{IL} ; $ V_{SW} = V_{CC} - \text{GND}$; see Figure 10				
		per channel	-	-	± 0.1	μA
		all channels	-	-	± 0.8	μA
$I_{S(ON)}$	ON-state leakage current	$V_{CC} = 5.5\text{ V}$; $V_I = V_{IH}$ or V_{IL} ; $ V_{SW} = V_{CC} - \text{GND}$; see Figure 11	-	-	± 0.8	μA
I_{CC}	supply current	$V_I = V_{CC}$ or GND; $V_{is} = \text{GND}$ or V_{CC} ; $V_{os} = V_{CC}$ or GND; $V_{CC} = 4.5\text{ V to }5.5\text{ V}$	-	-	8.0	μA
ΔI_{CC}	additional supply current	per input pin; $V_I = V_{CC} - 2.1\text{ V}$; other inputs at V_{CC} or GND; $V_{CC} = 4.5\text{ V to }5.5\text{ V}$				
		pin \bar{E}	-	60	216	μA
		pin Sn	-	50	180	μA
C_I	input capacitance		-	3.5	-	pF
$T_{amb} = -40\text{ }^\circ\text{C to }+85\text{ }^\circ\text{C}$						
V_{IH}	HIGH-level input voltage	$V_{CC} = 4.5\text{ V to }5.5\text{ V}$	2.0	-	-	V
V_{IL}	LOW-level input voltage	$V_{CC} = 4.5\text{ V to }5.5\text{ V}$	-	-	0.8	V
I_I	input leakage current	$V_I = V_{CC}$ or GND; $V_{CC} = 5.5\text{ V}$	-	-	± 1.0	μA
$I_{S(OFF)}$	OFF-state leakage current	$V_{CC} = 5.5\text{ V}$; $V_I = V_{IH}$ or V_{IL} ; $ V_{SW} = V_{CC} - \text{GND}$; see Figure 10				
		per channel	-	-	± 1.0	μA
		all channels	-	-	± 8.0	μA

Table 8. Static characteristics 74HCT4067 ...continued

At recommended operating conditions; voltages are referenced to GND (ground = 0 V).

V_{is} is the input voltage at a Yn or Z terminal, whichever is assigned as an input.

V_{os} is the output voltage at a Yn or Z terminal, whichever is assigned as an output.

Symbol	Parameter	Conditions	Min	Typ	Max	Unit
$I_{S(ON)}$	ON-state leakage current	$V_{CC} = 5.5\text{ V}$; $V_I = V_{IH}$ or V_{IL} ; $ V_{SW} = V_{CC} - \text{GND}$; see Figure 11	-	-	± 8.0	μA
I_{CC}	supply current	$V_I = V_{CC}$ or GND; $V_{is} = \text{GND}$ or V_{CC} ; $V_{os} = V_{CC}$ or GND; $V_{CC} = 4.5\text{ V}$ to 5.5 V	-	-	80.0	μA
ΔI_{CC}	additional supply current	per input pin; $V_I = V_{CC} - 2.1\text{ V}$; other inputs at V_{CC} or GND; $V_{CC} = 4.5\text{ V}$ to 5.5 V				
		pin \bar{E}	-	-	270	μA
		pin Sn	-	-	225	μA
$T_{amb} = -40\text{ }^\circ\text{C}$ to $+125\text{ }^\circ\text{C}$						
V_{IH}	HIGH-level input voltage	$V_{CC} = 4.5\text{ V}$ to 5.5 V	2.0	-	-	V
V_{IL}	LOW-level input voltage	$V_{CC} = 4.5\text{ V}$ to 5.5 V	-	-	0.8	V
I_I	input leakage current	$V_I = V_{CC}$ or GND; $V_{CC} = 5.5\text{ V}$	-	-	± 1.0	μA
$I_{S(OFF)}$	OFF-state leakage current	$V_{CC} = 5.5\text{ V}$; $V_I = V_{IH}$ or V_{IL} ; $ V_{SW} = V_{CC} - \text{GND}$; see Figure 10				
		per channel	-	-	± 1.0	μA
		all channels	-	-	± 8.0	μA
$I_{S(ON)}$	ON-state leakage current	$V_{CC} = 5.5\text{ V}$; $V_I = V_{IH}$ or V_{IL} ; $ V_{SW} = V_{CC} - \text{GND}$; see Figure 11	-	-	± 8.0	μA
I_{CC}	supply current	$V_I = V_{CC}$ or GND; $V_{is} = \text{GND}$ or V_{CC} ; $V_{os} = V_{CC}$ or GND; $V_{CC} = 4.5\text{ V}$ to 5.5 V	-	-	160	μA
ΔI_{CC}	additional supply current	per input pin; $V_I = V_{CC} - 2.1\text{ V}$; other inputs at V_{CC} or GND; $V_{CC} = 4.5\text{ V}$ to 5.5 V				
		pin \bar{E}	-	-	294	μA
		pin Sn	-	-	245	μA

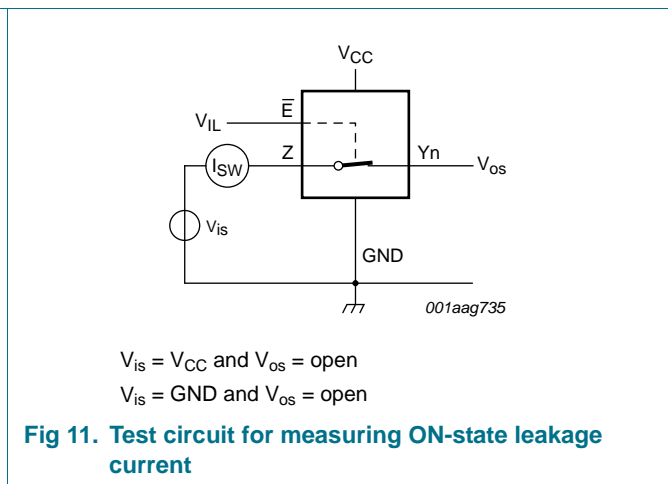
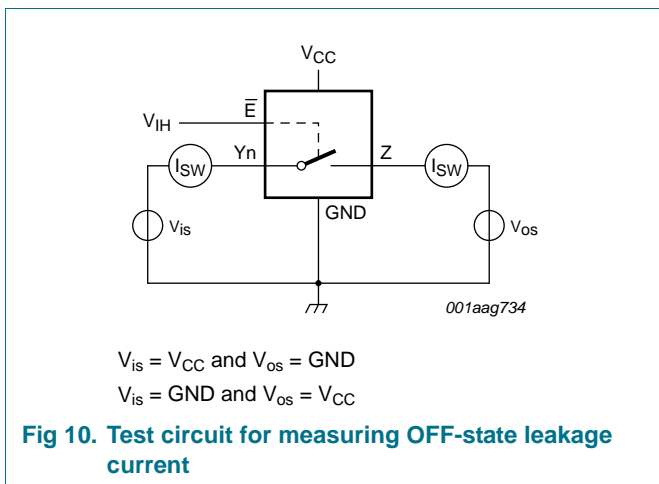

11. Dynamic characteristics

Table 9. Dynamic characteristics 74HC4067

$GND = 0\text{ V}$; $t_r = t_f = 6\text{ ns}$; $C_L = 50\text{ pF}$ unless specified otherwise; for test circuit see [Figure 14](#).

V_{is} is the input voltage at a Y_n or Z terminal, whichever is assigned as an input.

V_{os} is the output voltage at a Y_n or Z terminal, whichever is assigned as an output.

Symbol	Parameter	Conditions	25 °C		-40 °C to +125 °C		Unit		
			Typ	Max	Max (85 °C)	Max (125 °C)			
t_{pd}	propagation delay	Yn to Z; see Figure 12 [1][2]							
		$V_{CC} = 2.0\text{ V}$	25	75	95	110	ns		
		$V_{CC} = 4.5\text{ V}$	9	15	19	22	ns		
		$V_{CC} = 6.0\text{ V}$	7	13	16	19	ns		
		$V_{CC} = 9.0\text{ V}$	5	9	11	14	ns		
		Z to Yn							
		$V_{CC} = 2.0\text{ V}$	18	60	75	90	ns		
		$V_{CC} = 4.5\text{ V}$	6	12	15	18	ns		
		$V_{CC} = 6.0\text{ V}$	5	10	13	15	ns		
		$V_{CC} = 9.0\text{ V}$	4	8	10	12	ns		
		t_{off}	turn-off time	\bar{E} to Yn; see Figure 13 [3]					
				$V_{CC} = 2.0\text{ V}$	74	250	315	375	ns
				$V_{CC} = 4.5\text{ V}$	27	50	63	75	ns
				$V_{CC} = 5.0\text{ V}$; $C_L = 15\text{ pF}$	27	-	-	-	ns
$V_{CC} = 6.0\text{ V}$	22			43	54	64	ns		
$V_{CC} = 9.0\text{ V}$	20			38	48	57	ns		
Sn to Yn									
$V_{CC} = 2.0\text{ V}$	83			250	315	375	ns		
$V_{CC} = 4.5\text{ V}$	30			50	63	75	ns		
$V_{CC} = 5.0\text{ V}$; $C_L = 15\text{ pF}$	29			-	-	-	ns		
$V_{CC} = 6.0\text{ V}$	24			43	54	64	ns		
$V_{CC} = 9.0\text{ V}$	21			38	48	57	ns		
\bar{E} to Z									
$V_{CC} = 2.0\text{ V}$	85			275	345	415	ns		
$V_{CC} = 4.5\text{ V}$	31			55	69	83	ns		
$V_{CC} = 6.0\text{ V}$	25			47	59	71	ns		
$V_{CC} = 9.0\text{ V}$	24			42	53	63	ns		
Sn to Z									
$V_{CC} = 2.0\text{ V}$	94			290	365	435	ns		
$V_{CC} = 4.5\text{ V}$	34			58	73	87	ns		
$V_{CC} = 6.0\text{ V}$	27			47	62	74	ns		
$V_{CC} = 9.0\text{ V}$	25			45	56	68	ns		

Table 9. Dynamic characteristics 74HC4067 ...continued

$GND = 0\text{ V}$; $t_r = t_f = 6\text{ ns}$; $C_L = 50\text{ pF}$ unless specified otherwise; for test circuit see [Figure 14](#).

V_{is} is the input voltage at a Yn or Z terminal, whichever is assigned as an input.

V_{os} is the output voltage at a Yn or Z terminal, whichever is assigned as an output.

Symbol	Parameter	Conditions	25 °C		-40 °C to +125 °C		Unit	
			Typ	Max	Max (85 °C)	Max (125 °C)		
t_{on}	turn-on time	\bar{E} to Yn; see Figure 13		[4]				
		$V_{CC} = 2.0\text{ V}$	80	275	345	415	ns	
		$V_{CC} = 4.5\text{ V}$	29	55	69	83	ns	
		$V_{CC} = 5.0\text{ V}$; $C_L = 15\text{ pF}$	26	-	-	-	ns	
		$V_{CC} = 6.0\text{ V}$	23	47	59	71	ns	
		$V_{CC} = 9.0\text{ V}$	17	42	53	63	ns	
		Sn to Yn						
		$V_{CC} = 2.0\text{ V}$	88	300	375	450	ns	
		$V_{CC} = 4.5\text{ V}$	32	60	75	90	ns	
		$V_{CC} = 5.0\text{ V}$; $C_L = 15\text{ pF}$	29	-	-	-	ns	
		$V_{CC} = 6.0\text{ V}$	26	51	64	77	ns	
		$V_{CC} = 9.0\text{ V}$	18	45	56	68	ns	
		\bar{E} to Z						
		$V_{CC} = 2.0\text{ V}$	85	275	345	415	ns	
		$V_{CC} = 4.5\text{ V}$	31	55	69	83	ns	
		$V_{CC} = 6.0\text{ V}$	25	47	59	71	ns	
		$V_{CC} = 9.0\text{ V}$	18	42	53	63	ns	
		Sn to Z						
		$V_{CC} = 2.0\text{ V}$	94	300	375	450	ns	
		$V_{CC} = 4.5\text{ V}$	34	60	75	90	ns	
		$V_{CC} = 6.0\text{ V}$	27	51	64	77	ns	
$V_{CC} = 9.0\text{ V}$	19	45	56	68	ns			
C_{PD}	power dissipation capacitance	per switch; $V_I = GND$ to V_{CC}	[5]	29	-	-	-	pF

[1] t_{pd} is the same as t_{PHL} and t_{PLH} .

[2] Due to higher Z terminal capacitance (16 switches versus 1) the delay figures to the Z terminal are higher than those to the Y terminal.

[3] t_{on} is the same as t_{PHZ} and t_{PLZ} .

[4] t_{off} is the same as t_{PZH} and t_{PZL} .

[5] C_{PD} is used to determine the dynamic power dissipation (P_D in μW).

$$P_D = C_{PD} \times V_{CC}^2 \times f_i + \sum\{(C_L + C_{sw}) \times V_{CC}^2 \times f_o\}$$

f_i = input frequency in MHz;

f_o = output frequency in MHz;

$\sum\{(C_L + C_{sw}) \times V_{CC}^2 \times f_o\}$ = sum of outputs;

C_L = output load capacitance in pF;

C_{sw} = switch capacitance in pF;

V_{CC} = supply voltage in V.

Table 10. Dynamic characteristics 74HCT4067

$GND = 0\text{ V}$; $t_r = t_f = 6\text{ ns}$; $C_L = 50\text{ pF}$ unless specified otherwise; for test circuit see [Figure 14](#).

V_{is} is the input voltage at a Yn or Z terminal, whichever is assigned as an input.

V_{os} is the output voltage at a Yn or Z terminal, whichever is assigned as an output.

Symbol	Parameter	Conditions	25 °C		-40 °C to +125 °C		Unit
			Typ	Max	Max (85 °C)	Max (125 °C)	
t_{pd}	propagation delay	Yn to Z; see Figure 12 [1][2]					
		$V_{CC} = 4.5\text{ V}$	9	15	19	22	ns
		Z to Yn					
		$V_{CC} = 4.5\text{ V}$	6	12	15	18	ns
t_{off}	turn-off time	\bar{E} to Yn; see Figure 13 [3]					
		$V_{CC} = 4.5\text{ V}$	26	55	69	83	ns
		$V_{CC} = 5.0\text{ V}$; $C_L = 15\text{ pF}$	26	-	-	-	ns
		Sn to Yn					
		$V_{CC} = 4.5\text{ V}$	31	55	69	83	ns
		$V_{CC} = 5.0\text{ V}$; $C_L = 15\text{ pF}$	30	-	-	-	ns
		\bar{E} to Z					
		$V_{CC} = 4.5\text{ V}$	30	60	75	90	ns
t_{on}	turn-on time	Sn to Z					
		$V_{CC} = 4.5\text{ V}$	35	60	75	90	ns
		\bar{E} to Yn; see Figure 13 [4]					
		$V_{CC} = 4.5\text{ V}$	32	60	75	90	ns
		$V_{CC} = 5.0\text{ V}$; $C_L = 15\text{ pF}$	32	-	-	-	ns
		Sn to Yn					
		$V_{CC} = 4.5\text{ V}$	35	60	75	90	ns
		$V_{CC} = 5.0\text{ V}$; $C_L = 15\text{ pF}$	33	-	-	-	ns
		\bar{E} to Z					
		$V_{CC} = 4.5\text{ V}$	38	65	81	98	ns
		Sn to Z					
		$V_{CC} = 4.5\text{ V}$	38	65	81	98	ns
C_{PD}	power dissipation capacitance	per switch; $V_I = GND$ to $(V_{CC} - 1.5\text{ V})$ [5]	29	-	-	-	pF

[1] t_{pd} is the same as t_{PHL} and t_{PLH} .

[2] Due to higher Z terminal capacitance (16 switches versus 1) the delay figures to the Z terminal are higher than those to the Y terminal.

[3] t_{on} is the same as t_{PHZ} and t_{PLZ} .

[4] t_{off} is the same as t_{PZH} and t_{PZL} .

[5] C_{PD} is used to determine the dynamic power dissipation (P_D in μW).

$$P_D = C_{PD} \times V_{CC}^2 \times f_i + \sum\{(C_L + C_{sw}) \times V_{CC}^2 \times f_o\}$$

where:

f_i = input frequency in MHz;

f_o = output frequency in MHz;

$\sum\{(C_L + C_{sw}) \times V_{CC}^2 \times f_o\}$ = sum of outputs;

C_L = output load capacitance in pF;

C_{sw} = switch capacitance in pF;

V_{CC} = supply voltage in V.

12. Waveforms

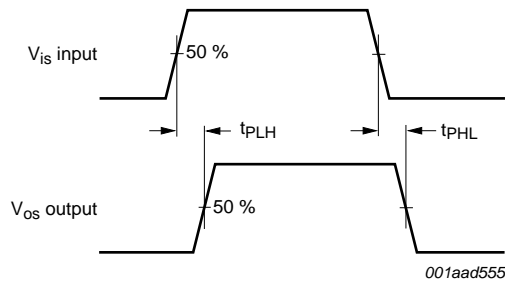
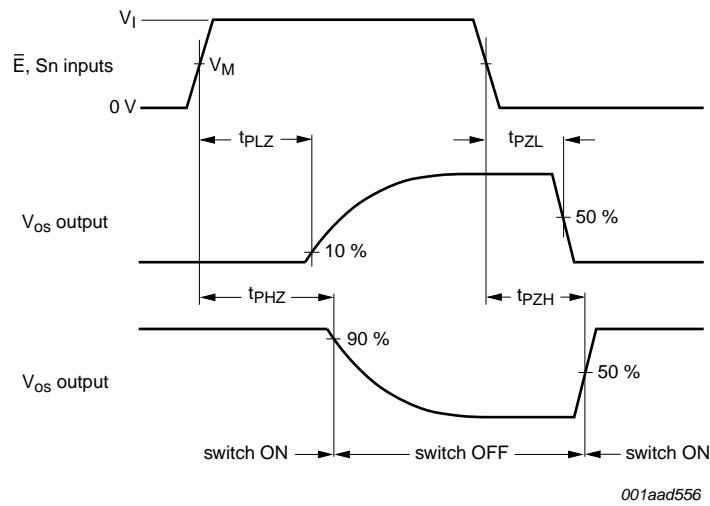

Fig 12. Input (V_{is}) to output (V_{os}) propagation delays



Measurement points are shown in [Table 11](#).

Fig 13. Turn-on and turn-off times

Table 11. Measurement points

Type	V_I	V_M
74HC4067	V_{CC}	$0.5V_{CC}$
74HCT4067	3.0 V	1.3 V

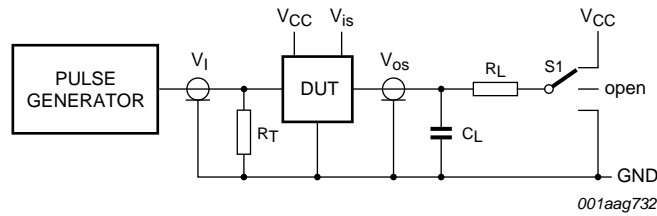
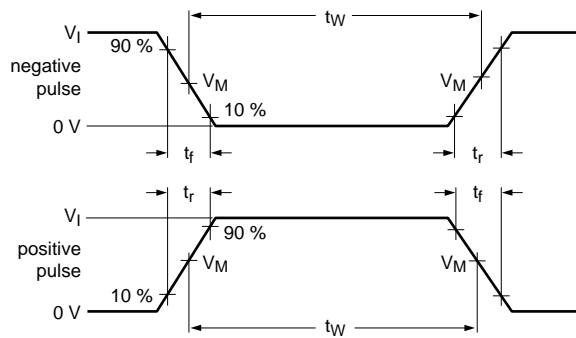

Test data is given in [Table 12](#).

Definitions test circuit:

R_T = Termination resistance should be equal to output impedance Z_o of the pulse generator.

C_L = Load capacitance including jig and probe capacitance.

R_L = Load resistor.

S1 = Test selection switch.

Fig 14. Load circuitry for measuring switching times

Table 12. Test data

Test	Input				Output		S1 position
	Control \bar{E}	Address Sn	Switch Yn (Z)	t_r, t_f	Switch Z (Yn)		
	V_I [1]	V_I [1]	V_{is}		C_L	R_L	
t_{PHL}, t_{PLH}	GND	GND or V_{CC}	GND to V_{CC}	6 ns	50 pF	-	open
t_{PHZ}, t_{PZH}	GND to V_{CC}	GND to V_{CC}	V_{CC}	6 ns	50 pF, 15 pF	1 k Ω	GND
t_{PLZ}, t_{PZL}	GND to V_{CC}	GND to V_{CC}	GND	6 ns	50 pF, 15 pF	1 k Ω	V_{CC}

[1] For 74HCT4067: maximum input voltage $V_I = 3.0$ V.

13. Additional dynamic characteristics

Table 13. Additional dynamic characteristics

Recommended conditions and typical values; $GND = 0\text{ V}$; $T_{amb} = 25\text{ }^\circ\text{C}$.

V_{is} is the input voltage at a Yn or Z terminal, whichever is assigned as an input.

V_{os} is the output voltage at a Yn or Z terminal, whichever is assigned as an output.

Symbol	Parameter	Conditions	Min	Typ	Max	Unit
THD	total harmonic distortion	$R_L = 10\text{ k}\Omega$; $C_L = 50\text{ pF}$; see Figure 15				
		$f_i = 1\text{ kHz}$				
		$V_{CC} = 4.5\text{ V}$; $V_{is(p-p)} = 4.0\text{ V}$	-	0.04	-	%
		$V_{CC} = 9.0\text{ V}$; $V_{is(p-p)} = 8.0\text{ V}$	-	0.02	-	%
		$f_i = 10\text{ kHz}$				
		$V_{CC} = 4.5\text{ V}$; $V_{is(p-p)} = 4.0\text{ V}$	-	0.12	-	%
α_{iso}	isolation (OFF-state)	$R_L = 600\text{ }\Omega$; $C_L = 50\text{ pF}$; see Figure 16	[1]			
		$V_{CC} = 4.5\text{ V}$	-	-50	-	dB
		$V_{CC} = 9.0\text{ V}$	-	-50	-	dB
$f_{(-3dB)}$	-3 dB frequency response	$R_L = 50\text{ }\Omega$; $C_L = 10\text{ pF}$; see Figure 17	[2]			
		$V_{CC} = 4.5\text{ V}$	-	90	-	MHz
		$V_{CC} = 9.0\text{ V}$	-	100	-	MHz
C_{sw}	switch capacitance	independent pins Y	-	5	-	pF
		common pin Z	-	45	-	pF

[1] Adjust input voltage V_{is} to 0 dBm level (0 dBm = 1 mW into 600 Ω).

[2] Adjust input voltage V_{is} to 0 dBm level at V_{os} for $f_i = 1\text{ MHz}$ (0 dBm = 1 mW into 50 Ω). After set-up, f_i is increased to obtain a reading of -3 dB at V_{os} .

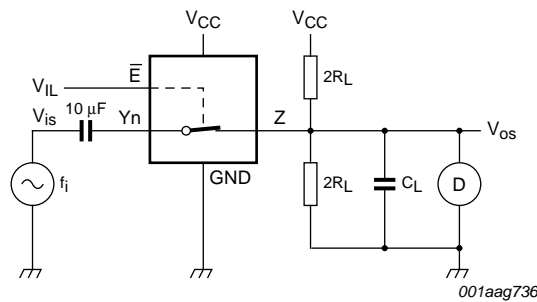
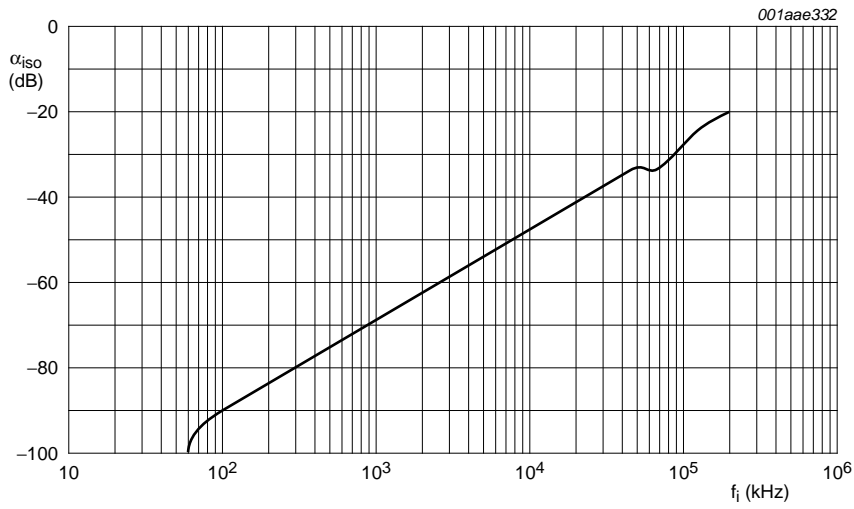
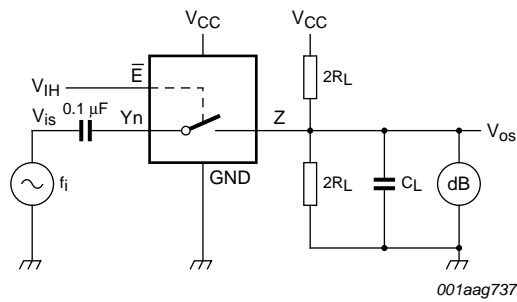

Fig 15. Test circuit for measuring total harmonic distortion



a. Isolation (OFF-state)



b. Test circuit

$V_{CC} = 4.5\text{ V}$; $GND = 0\text{ V}$; $R_L = 600\ \Omega$; $R_{source} = 1\text{ k}\Omega$.

Fig 16. Isolation (OFF-state) as a function of frequency

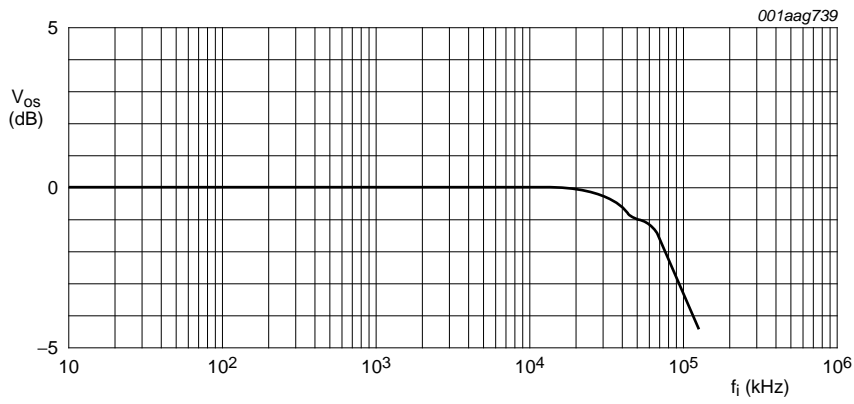

a. Typical -3 dB frequency response

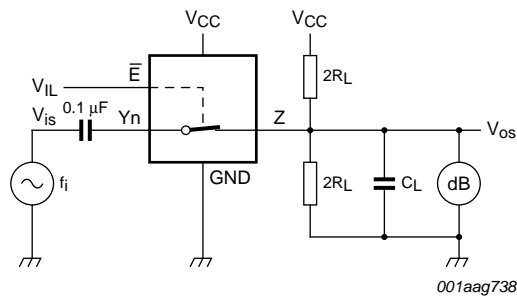

b. Test circuit

$V_{CC} = 4.5\text{ V}$; $GND = 0\text{ V}$; $R_L = 50\ \Omega$; $R_{source} = 1\text{ k}\Omega$.

Fig 17. -3 dB frequency response

14. Package outline

DIP24: plastic dual in-line package; 24 leads (600 mil)

SOT101-1

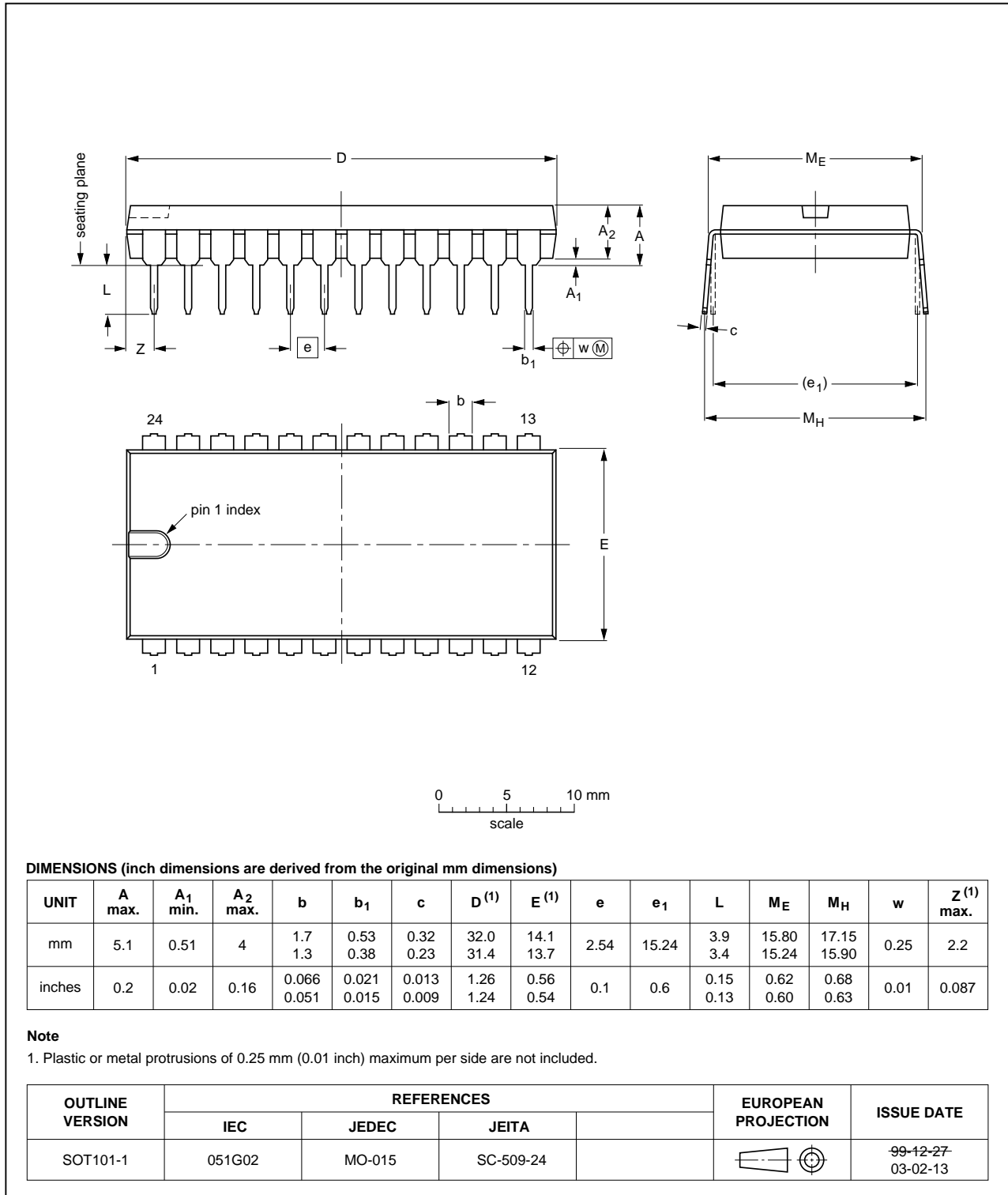

Fig 18. Package outline SOT101-1 (DIP24)

SO24: plastic small outline package; 24 leads; body width 7.5 mm

SOT137-1

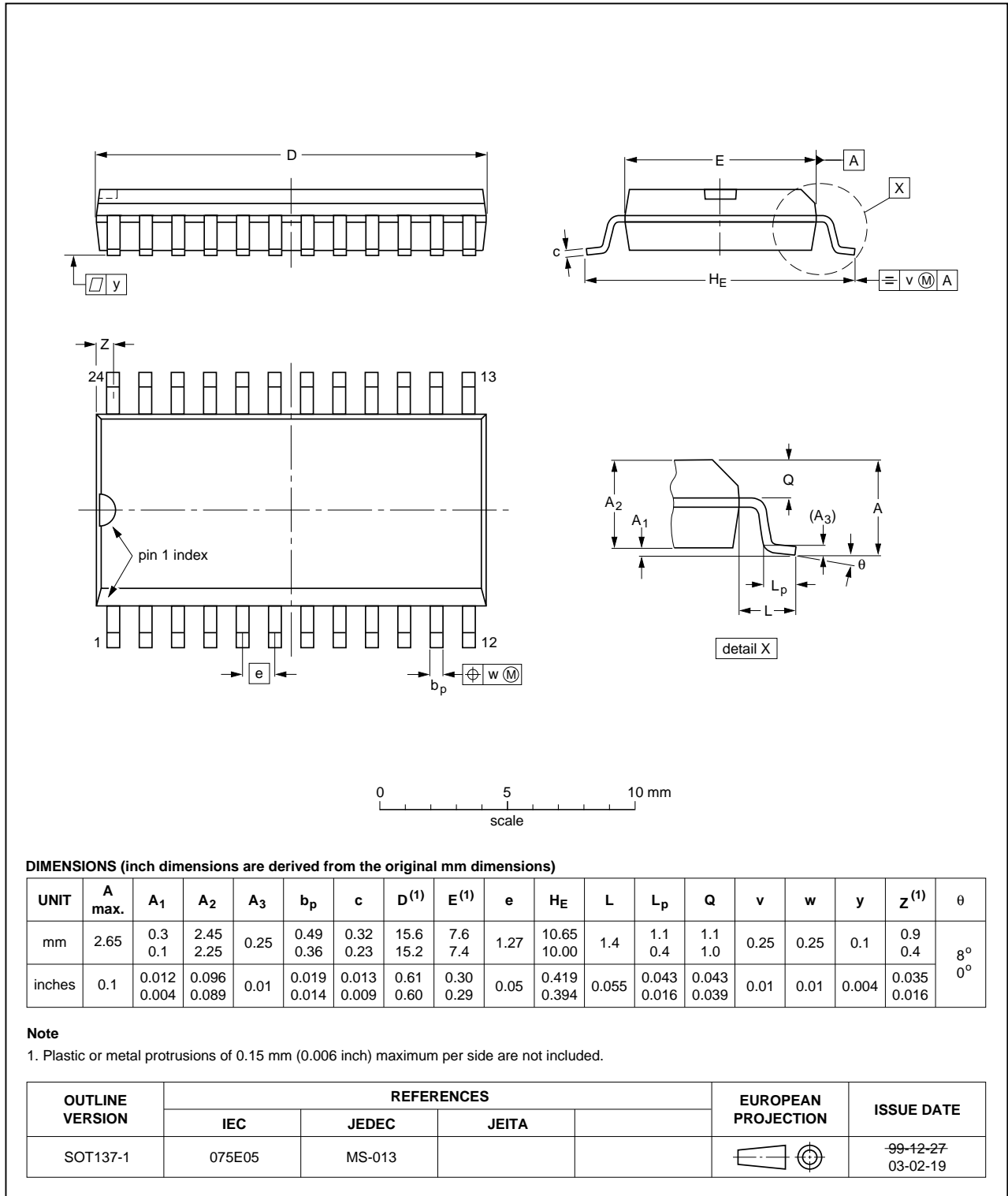

Fig 19. Package outline SOT137-1 (SO24)

SSOP24: plastic shrink small outline package; 24 leads; body width 5.3 mm

SOT340-1

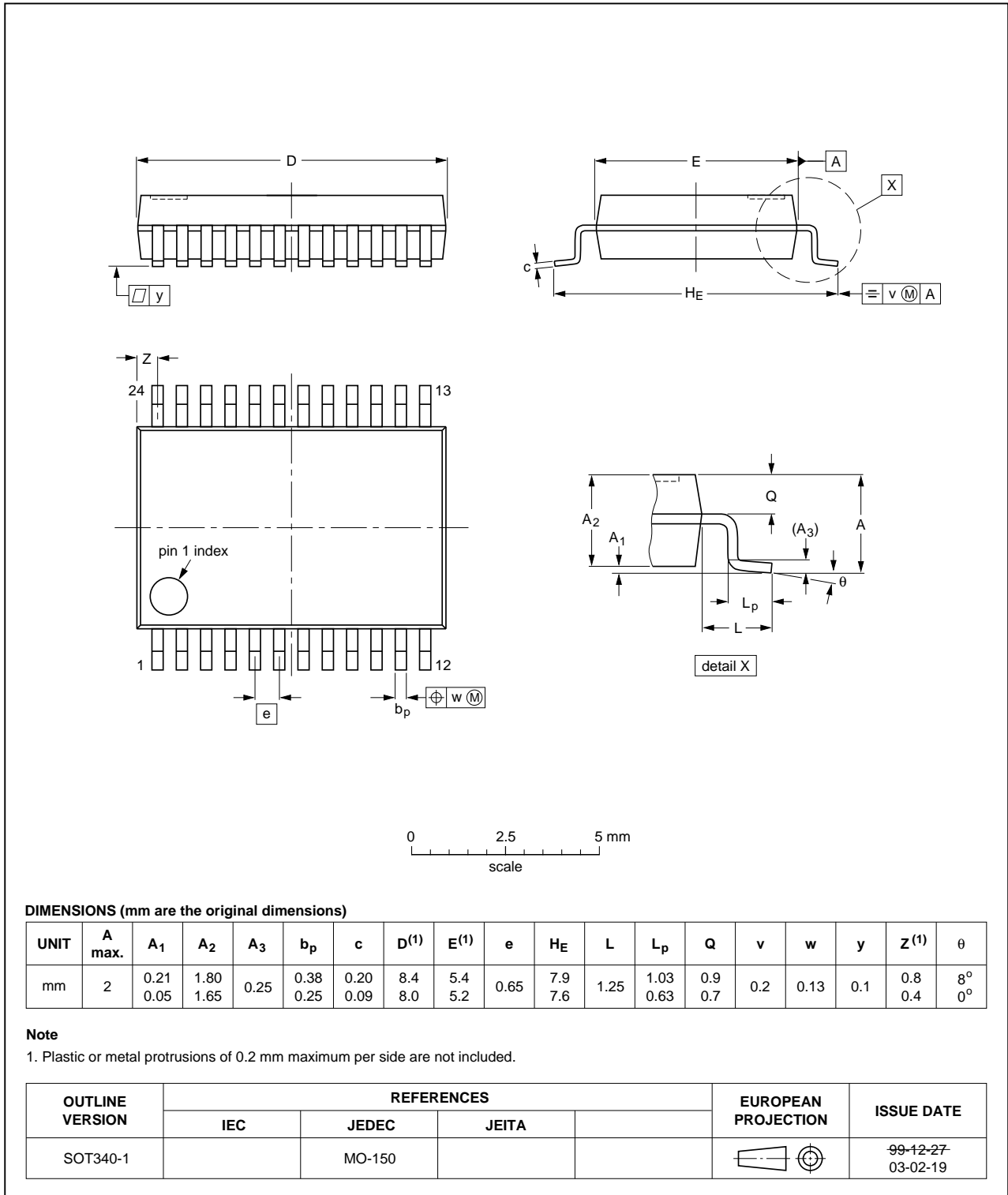

Fig 20. Package outline SOT340-1 (SSOP24)

TSSOP24: plastic thin shrink small outline package; 24 leads; body width 4.4 mm

SOT355-1

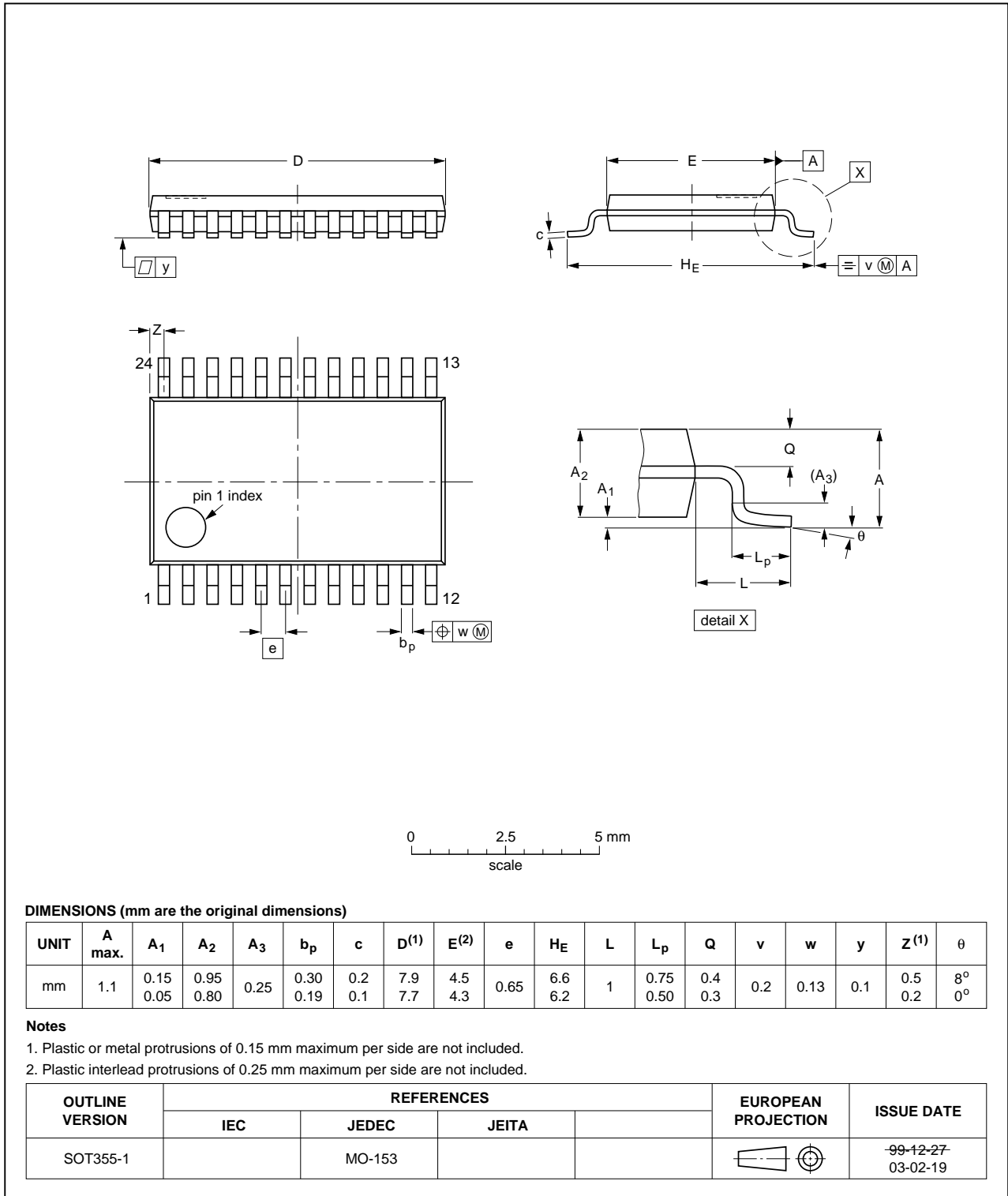

Fig 21. Package outline SOT355-1 (TSSOP24)

DHVQFN24: plastic dual in-line compatible thermal enhanced very thin quad flat package; no leads; 24 terminals; body 3.5 x 5.5 x 0.85 mm

SOT815-1

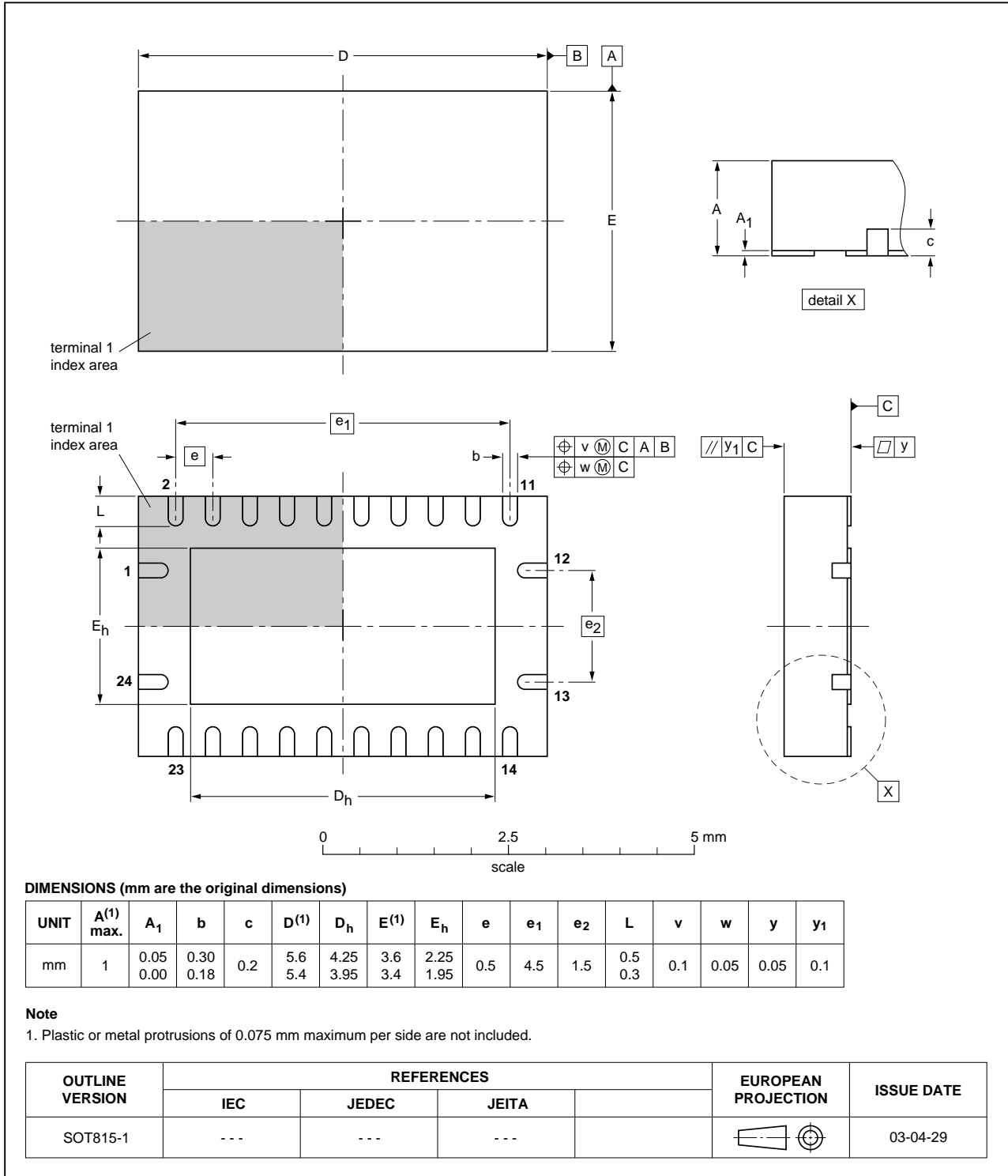

Fig 22. Package outline SOT815-1 (DHVQFN24)

15. Revision history

Table 14. Revision history

Document ID	Release date	Data sheet status	Change notice	Supersedes
74HC_HCT4067 v.5	20111213	Product data sheet	-	74HC_HCT4067 v.4
Modifications:	• Legal pages updated.			
74HC_HCT4067 v.4	20110518	Product data sheet	-	74HC_HCT4067 v.3
74HC_HCT4067 v.3	20071015	Product data sheet	-	74HC_HCT4067_CNV v.2
74HC_HCT4067_CNV v.2	19970901	Product specification	-	-

16. Legal information

16.1 Data sheet status

Document status ^{[1][2]}	Product status ^[3]	Definition
Objective [short] data sheet	Development	This document contains data from the objective specification for product development.
Preliminary [short] data sheet	Qualification	This document contains data from the preliminary specification.
Product [short] data sheet	Production	This document contains the product specification.

[1] Please consult the most recently issued document before initiating or completing a design.

[2] The term 'short data sheet' is explained in section "Definitions".

[3] The product status of device(s) described in this document may have changed since this document was published and may differ in case of multiple devices. The latest product status information is available on the Internet at URL <http://www.nxp.com>.

16.2 Definitions

Draft — The document is a draft version only. The content is still under internal review and subject to formal approval, which may result in modifications or additions. NXP Semiconductors does not give any representations or warranties as to the accuracy or completeness of information included herein and shall have no liability for the consequences of use of such information.

Short data sheet — A short data sheet is an extract from a full data sheet with the same product type number(s) and title. A short data sheet is intended for quick reference only and should not be relied upon to contain detailed and full information. For detailed and full information see the relevant full data sheet, which is available on request via the local NXP Semiconductors sales office. In case of any inconsistency or conflict with the short data sheet, the full data sheet shall prevail.

Product specification — The information and data provided in a Product data sheet shall define the specification of the product as agreed between NXP Semiconductors and its customer, unless NXP Semiconductors and customer have explicitly agreed otherwise in writing. In no event however, shall an agreement be valid in which the NXP Semiconductors product is deemed to offer functions and qualities beyond those described in the Product data sheet.

16.3 Disclaimers

Limited warranty and liability — Information in this document is believed to be accurate and reliable. However, NXP Semiconductors does not give any representations or warranties, expressed or implied, as to the accuracy or completeness of such information and shall have no liability for the consequences of use of such information.

In no event shall NXP Semiconductors be liable for any indirect, incidental, punitive, special or consequential damages (including - without limitation - lost profits, lost savings, business interruption, costs related to the removal or replacement of any products or rework charges) whether or not such damages are based on tort (including negligence), warranty, breach of contract or any other legal theory.

Notwithstanding any damages that customer might incur for any reason whatsoever, NXP Semiconductors' aggregate and cumulative liability towards customer for the products described herein shall be limited in accordance with the *Terms and conditions of commercial sale* of NXP Semiconductors.

Right to make changes — NXP Semiconductors reserves the right to make changes to information published in this document, including without limitation specifications and product descriptions, at any time and without notice. This document supersedes and replaces all information supplied prior to the publication hereof.

Suitability for use — NXP Semiconductors products are not designed, authorized or warranted to be suitable for use in life support, life-critical or safety-critical systems or equipment, nor in applications where failure or

malfunction of an NXP Semiconductors product can reasonably be expected to result in personal injury, death or severe property or environmental damage. NXP Semiconductors accepts no liability for inclusion and/or use of NXP Semiconductors products in such equipment or applications and therefore such inclusion and/or use is at the customer's own risk.

Applications — Applications that are described herein for any of these products are for illustrative purposes only. NXP Semiconductors makes no representation or warranty that such applications will be suitable for the specified use without further testing or modification.

Customers are responsible for the design and operation of their applications and products using NXP Semiconductors products, and NXP Semiconductors accepts no liability for any assistance with applications or customer product design. It is customer's sole responsibility to determine whether the NXP Semiconductors product is suitable and fit for the customer's applications and products planned, as well as for the planned application and use of customer's third party customer(s). Customers should provide appropriate design and operating safeguards to minimize the risks associated with their applications and products.

NXP Semiconductors does not accept any liability related to any default, damage, costs or problem which is based on any weakness or default in the customer's applications or products, or the application or use by customer's third party customer(s). Customer is responsible for doing all necessary testing for the customer's applications and products using NXP Semiconductors products in order to avoid a default of the applications and the products or of the application or use by customer's third party customer(s). NXP does not accept any liability in this respect.

Limiting values — Stress above one or more limiting values (as defined in the Absolute Maximum Ratings System of IEC 60134) will cause permanent damage to the device. Limiting values are stress ratings only and (proper) operation of the device at these or any other conditions above those given in the Recommended operating conditions section (if present) or the Characteristics sections of this document is not warranted. Constant or repeated exposure to limiting values will permanently and irreversibly affect the quality and reliability of the device.

Terms and conditions of commercial sale — NXP Semiconductors products are sold subject to the general terms and conditions of commercial sale, as published at <http://www.nxp.com/profile/terms>, unless otherwise agreed in a valid written individual agreement. In case an individual agreement is concluded only the terms and conditions of the respective agreement shall apply. NXP Semiconductors hereby expressly objects to applying the customer's general terms and conditions with regard to the purchase of NXP Semiconductors products by customer.

No offer to sell or license — Nothing in this document may be interpreted or construed as an offer to sell products that is open for acceptance or the grant, conveyance or implication of any license under any copyrights, patents or other industrial or intellectual property rights.

Export control — This document as well as the item(s) described herein may be subject to export control regulations. Export might require a prior authorization from competent authorities.

Non-automotive qualified products — Unless this data sheet expressly states that this specific NXP Semiconductors product is automotive qualified, the product is not suitable for automotive use. It is neither qualified nor tested in accordance with automotive testing or application requirements. NXP Semiconductors accepts no liability for inclusion and/or use of non-automotive qualified products in automotive equipment or applications.

In the event that customer uses the product for design-in and use in automotive applications to automotive specifications and standards, customer (a) shall use the product without NXP Semiconductors' warranty of the product for such automotive applications, use and specifications, and (b) whenever customer uses the product for automotive applications beyond

NXP Semiconductors' specifications such use shall be solely at customer's own risk, and (c) customer fully indemnifies NXP Semiconductors for any liability, damages or failed product claims resulting from customer design and use of the product for automotive applications beyond NXP Semiconductors' standard warranty and NXP Semiconductors' product specifications.

16.4 Trademarks

Notice: All referenced brands, product names, service names and trademarks are the property of their respective owners.

17. Contact information

For more information, please visit: <http://www.nxp.com>

For sales office addresses, please send an email to: salesaddresses@nxp.com

18. Contents

1	General description	1
2	Features and benefits	1
3	Applications	1
4	Ordering information	2
5	Functional diagram	3
6	Pinning information	6
6.1	Pinning	6
6.2	Pin description	6
7	Functional description	7
8	Limiting values	7
9	Recommended operating conditions	8
10	Static characteristics	9
11	Dynamic characteristics	14
12	Waveforms	17
13	Additional dynamic characteristics	19
14	Package outline	22
15	Revision history	27
16	Legal information	28
16.1	Data sheet status	28
16.2	Definitions	28
16.3	Disclaimers	28
16.4	Trademarks	29
17	Contact information	29
18	Contents	30

Please be aware that important notices concerning this document and the product(s) described herein, have been included in section 'Legal information'.

© NXP B.V. 2011.

All rights reserved.

For more information, please visit: <http://www.nxp.com>

For sales office addresses, please send an email to: salesaddresses@nxp.com

Date of release: 13 December 2011

Document identifier: 74HC_HCT4067