

660 Series

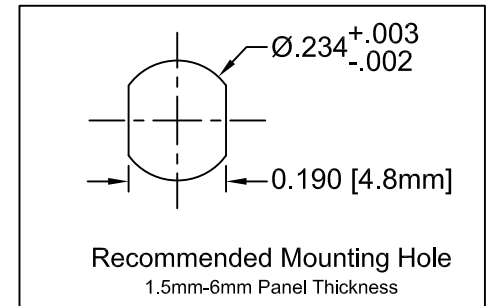
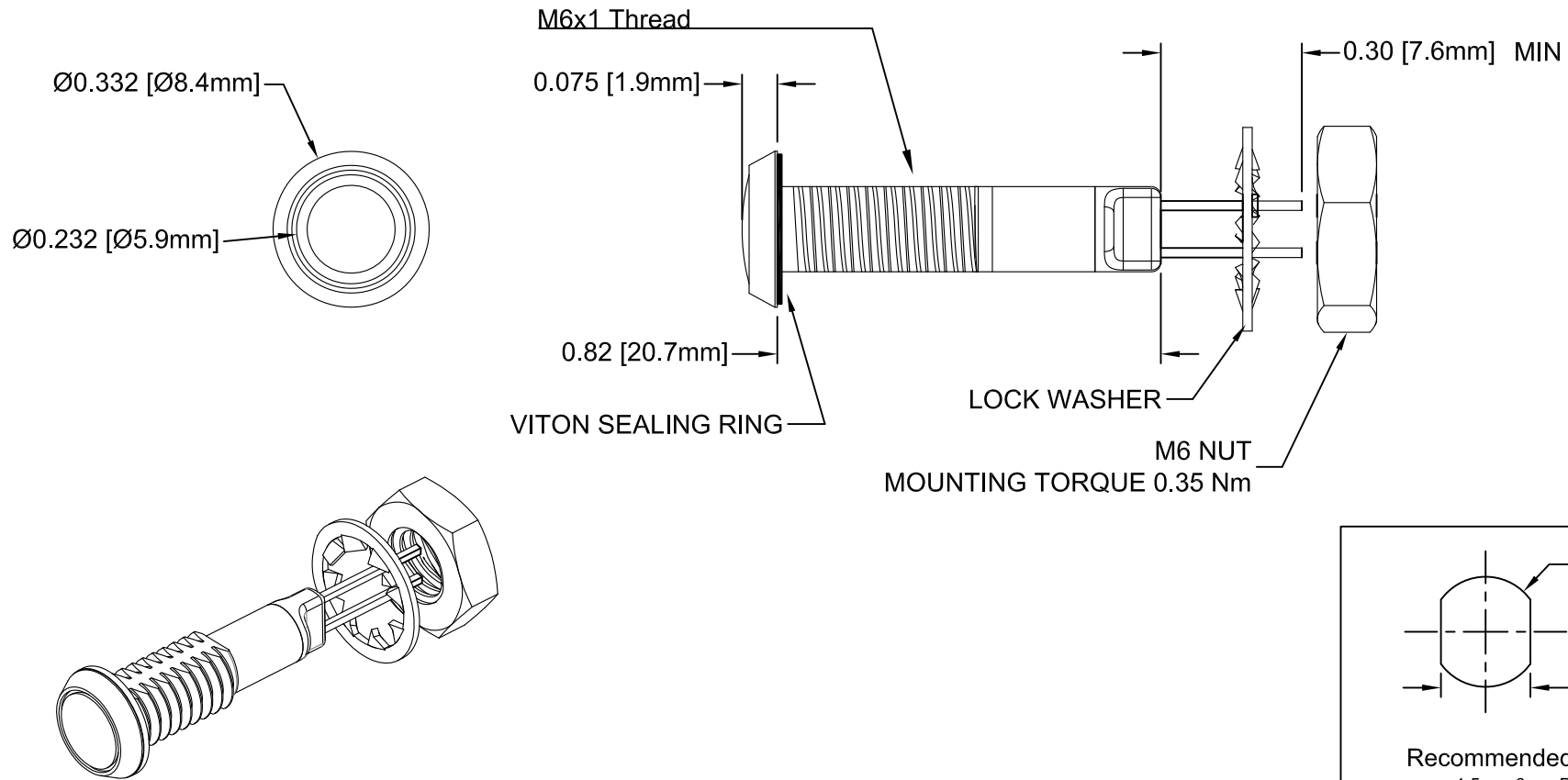

NOTES:

1. SEALED TO IP67 RATING
2. WIDE RANGE VOLTAGE INPUT, 8-48 VAC/VDC
3. BI-POLAR OPERATION
4. ROHS COMPLIANT
5. MOUNTING HARDWARE SHIPPED NON-ASSEMBLED
6. INSERT VITON RING ON PANEL MOUNT PRIOR TO PANEL INSERTION

STANDARD TOLERANCE (UNLESS OTHERWISE SPECIFIED)		MARL	MARL BUSINESS PARK, ULVERSTON, UK. LA12 9BN Tel: +44 (0)1229 582 430. Web: www.leds.co.uk
DECIMALS	ANGULAR		
.X ± .1	X° ± 1°		
.XX ± .02		TITLE: IP67 Rated Panel Mount Indicator	
.XXX ± .010		PART NO: 660 Series	
Provisional		SHEET # 1 OF 3	
<small>CAD GENERATED DOCUMENT, DO NOT MEASURE DRAWING.</small>			

660 Series (Flying Leads version)

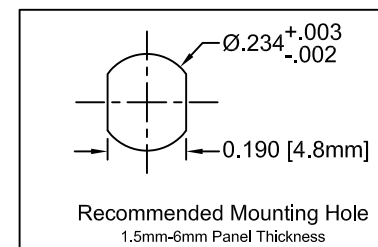
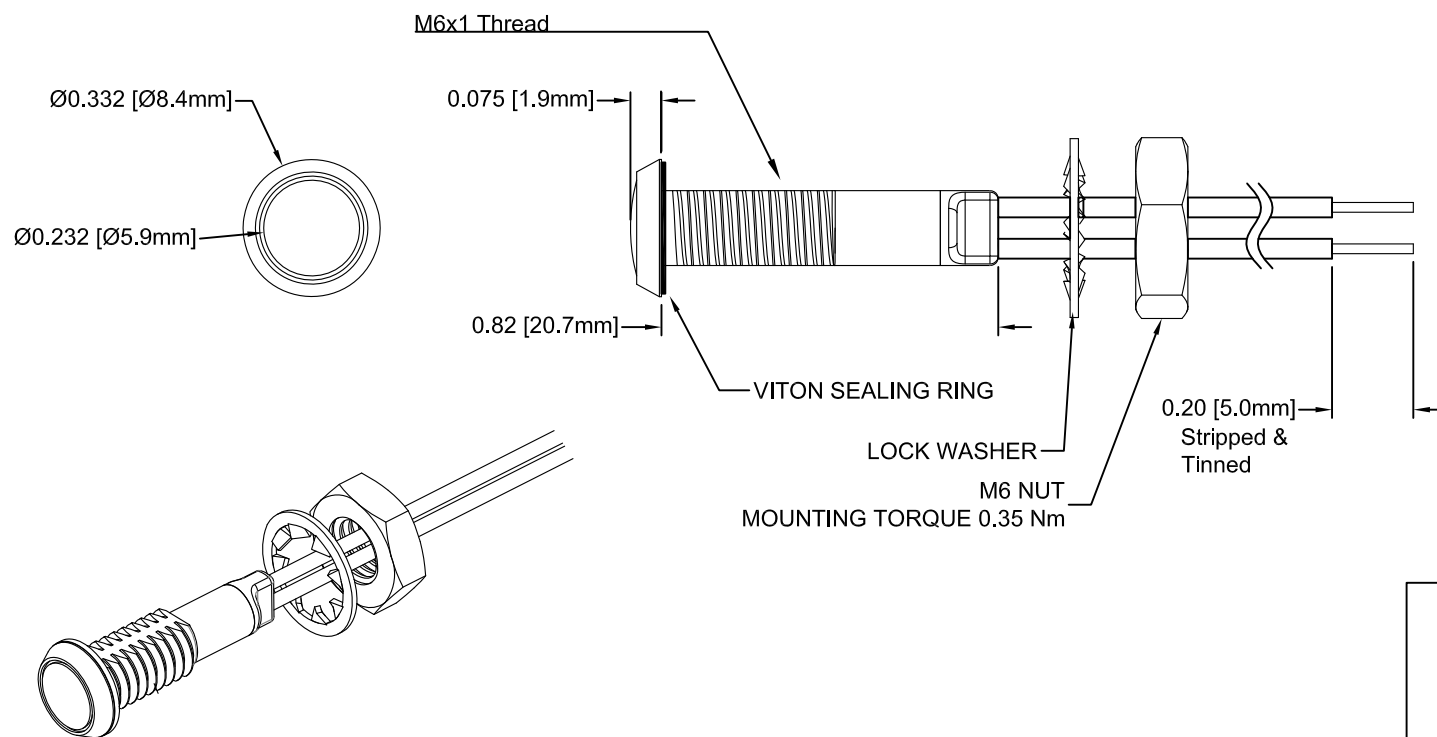

NOTES:

1. SEALED TO IP67 RATING
2. WIDE RANGE VOLTAGE INPUT, 8-48 VAC/VDC
3. BI-POLAR OPERATION
4. ROHS COMPLIANT
5. MOUNTING HARDWARE SHIPPED NON-ASSEMBLED
6. INSERT VITON RING ON PANEL MOUNT PRIOR TO PANEL INSERTION



STANDARD TOLERANCE (UNLESS OTHERWISE SPECIFIED)		MARL	MARL BUSINESS PARK, ULVERSTON, UK. LA12 9BN Tel: +44 (0)1229 582 430. Web: www.leds.co.uk
DECIMALS	ANGULAR		
.X ± .1	X° ± 1°		
.XX ± .02		TITLE: IP67 Rated Panel Mount Indicator	
.XXX ± .010		PART NO: 660 Series	
Provisional		SHEET # 2 OF 3	
<small>CAD GENERATED DOCUMENT, DO NOT MEASURE DRAWING.</small>			

Marl Part No.	LED Part Number	Peak Wave Length λ_p (nm)	Emitted Colour	Lens Appearance	Electro-Optical Data @ 20mA		Viewing Angle	Termination
					Typ Vf (VAC/VDC)	LED Iv (mcd)		
					TYP	TYP		
660-308-64	308	610	AMBER	WHITE DIFFUSED	8-48	100	120	PINS
660-308-64-40								12IN FLYING LEADS
660-320-64	320	470	BLUE	WHITE DIFFUSED	8-48	200	120	PINS
660-320-64-40								12IN FLYING LEADS
660-314-64	314	568	GREEN	WHITE DIFFUSED	8-48	30	120	PINS
660-314-64-40								12IN FLYING LEADS
660-302-64	302	625	HE RED	WHITE DIFFUSED	8-48	30	120	PINS
660-302-64-40								12IN FLYING LEADS
660-305-64	305	645	RED	WHITE DIFFUSED	8-48	40	120	PINS
660-305-64-40								12IN FLYING LEADS
660-311-64	311	585	YELLOW	WHITE DIFFUSED	8-48	30	120	PINS
660-311-64-40								12IN FLYING LEADS

Marl Part No.	LED Part Number	Colour Temperature	Emitted Colour	Lens Appearance	Electro-Optical Data @ 20mA		Viewing Angle	Termination
					Typ Vf (VAC/VDC)	LED Iv (mcd)		
					TYP	TYP		
660-998-64	998	5000K	NEUTRAL WHITE	WHITE DIFFUSED	8-48	2500	120	PINS
660-998-64-40								12IN FLYING LEADS

ABSOLUTE MAXIMUM RATINGS (Ta = 25°C)

MAXIMUM POWER DISSIPATION _____ 400 mW
 OPERATING TEMPERATURE RANGE _____ -30°C ~ 85°C
 STORAGE TEMPERATURE _____ -40°C ~ 85°C

STANDARD TOLERANCE (UNLESS OTHERWISE SPECIFIED) DECIMALS ANGULAR .X ± .1 X° ± 1° .XX ± .02 .XXX ± .010		 MARL BUSINESS PARK, ULVERSTON, UK. LA12 9BN Tel: +44 (0)1229 582 430. Web: www.leds.co.uk
		
<h1>Provisional</h1>		TITLE: IP67 Rated Panel Mount Indicator
		PART NO: 660 Series SHEET # 3 OF 3 <small>CAD GENERATED DOCUMENT, DO NOT MEASURE DRAWING.</small>