

Emitter Assembly ELM-3000 Series

Dual Drive
Ceramic Substrate
Pulse Oximetry Component

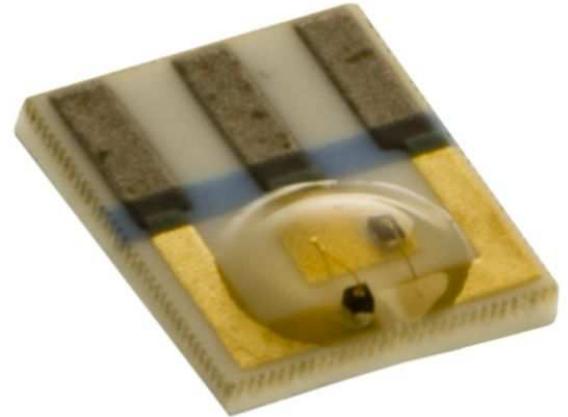

The ELM-3000 Series Emitter Assemblies are specially designed for medical applications where selection of peak wavelength is a key requirement. Emission source material is GaAlAs in conjunction with GaAlP complete with clear epoxy lens.

FEATURES

- Dual LEDs (Red & IR)
- 660 nm \pm 3 nm Peak Wavelength Red LED
- Two IR Wavelength Choices
- 2-Pin or 3-Pin Leadless Ceramic Substrate

APPLICATIONS

- Pulse Oximetry
- Finger/Ear Probes
- Soft Silicone Probes
- Medical Instrumentation

Dimensions (ELM-3001)

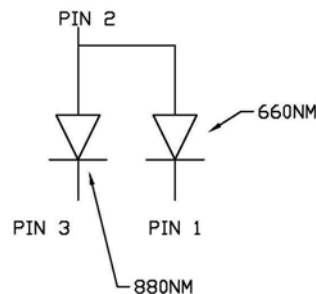
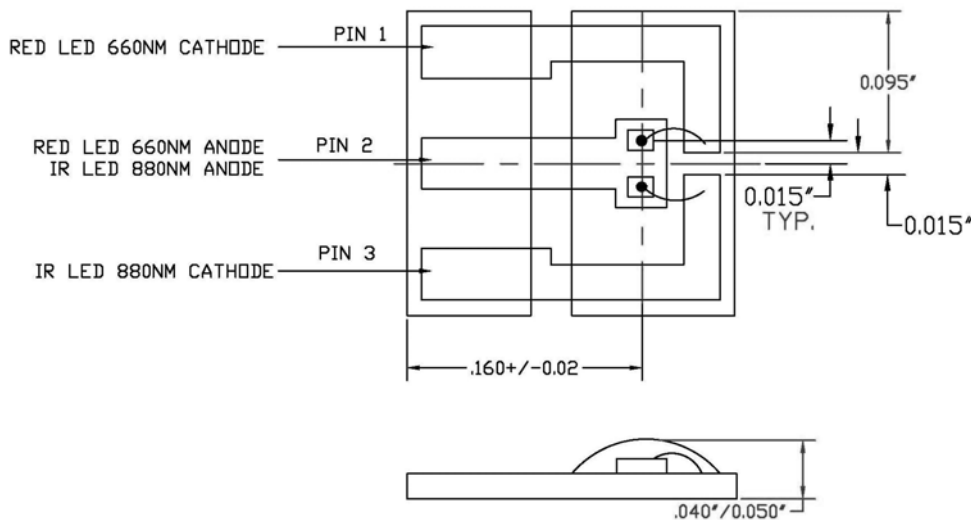

Emitter Assembly ELM-3000 Series

RED 660nm

Parameter @ 25°C	Symbol	Conditions	Min.	Typ.	Max.	Absolute	Unit
Forward Voltage	V_f	$I_f=20\text{mA}$		1.85	2.30		V
Reverse Voltage	V_{B_r}	$I_{br}=10\mu\text{A}$	3.0				V
Reverse Current	I_r	$V_r=3\text{V}$			100		μA
Luminous Intensity	L_v	$I_f=20\text{mA}$	25				Mcd
Peak Wavelength	λ_p	$I_f=20\text{mA}$	657	660	663		nm
Spectral Bandwidth	$\lambda\Delta$	$I_f=20\text{mA}$		20			nm

INFRARED 880nm (ELM-3001, ELM-3002)

Forward Voltage	V_f	$I_f=20\text{mA}$			1.50		V
Reverse Voltage	V_{B_r}	$I_{br}=10\mu\text{A}$	3.0				V
Reverse Current	I_r	$V_r=3\text{V}$			100		μA
Peak Wavelength	λ_p	$I_f=20\text{mA}$	870	880	890		nm
Spectral Bandwidth	$\lambda\Delta$	$I_f=20\text{mA}$		60	80		nm
Total Output	P_o	$I_f=20\text{mA}$	≥ 0.6	1			mW

INFRARED 940nm (ELM-3003, ELM-3004)

Forward Voltage	V_f	$I_f=20\text{mA}$		1.20	1.40		V
Reverse Voltage	V_{B_r}	$I_{br}=10\mu\text{A}$	5.0				V
Reverse Current	I_r	$V_r=3\text{V}$					μA
Peak Wavelength	λ_p	$I_f=20\text{mA}$	930	940	950		nm
Spectral Bandwidth	$\lambda\Delta$	$I_f=20\text{mA}$		45			nm
Total Output	P_o	$I_f=20\text{mA}$	≥ 0.6	1			mW

The information in this sheet has been carefully reviewed and is believed to be accurate; however, no responsibility is assumed for inaccuracies. Furthermore, this information does not convey to the purchaser of such devices any license under the patent rights to the manufacturer. Measurement Specialties, Inc. reserves the right to make changes without further notice to any product herein. Measurement Specialties, Inc. makes no warranty, representation or guarantee regarding the suitability of its product for any particular purpose, nor does Measurement Specialties, Inc. assume any liability arising out of the application or use of any product or circuit and specifically disclaims any and all liability, including without limitation consequential or incidental damages. Typical parameters can and do vary in different applications. All operating parameters must be validated for each customer application by customer's technical experts. Measurement Specialties, Inc. does not convey any license under its patent rights nor the rights of others.

Ordering Information

Description

Emitter Assembly; Ceramic 3-Lead; 660/880nm
Emitter Assembly; Ceramic 2-Lead; 660/880nm
Emitter Assembly; Ceramic 3-Lead; 660/940nm
Emitter Assembly; Ceramic 2-Lead; 660/940nm

Part Number

ELM-3001
ELM-3002
ELM-3003
ELM-3004

NORTH AMERICA

Measurement Specialties, Inc.
910 Turnpike Road
Shrewsbury, MA 01545
Tel: 1-508-842-0516
Fax: 1-508-842-0342

Sales:

temperature.sales.amer@meas-spec.com

EUROPE

Measurement Specialties, Inc.
Ballybrit Business Park
Galway Ireland
Tel: +353-91-753238
Fax: +353-91-770789

Sales:

temperature.sales.emea@meas-spec.com

ASIA

Measurement Specialties (China) Ltd.
No. 26 Langshan Road
Shenzhen High-Tech Park (North)
Nanshan District, Shenzhen 51807
China

Tel: +86 (0) 755 33305088

Fax: +86 (0) 755 33305099

Sales:

temperature.sales.asia@meas-spec.com

Emitter Assembly ELM-3000 Series