

Magnetic Length Sensor MLS (Hybrid)



Small Hybride



Large Hybride

- AMR gradient sensor
- Linear displacement, movements, velocities
- High precision
- Various pole pitches available

DESCRIPTION

Sliding the MLS-Sensors along a magnetic scale will produce a sine and a cosine output signal as a function of the position. In order to deliver satisfying results, this will be achieved as long as the air gap between sensor edge and magnetic scale does not exceed approximately half of the pole pitch. As the sensor principle is based on the anisotropic magneto resistance effect, the signal amplitudes are nearly independent on the magnetic field strength and therefore air gap variations do not have a strong effect on the accuracy. The sensor detects a magnetic gradient field and is thus almost insensitive to homogenous magnetic stray fields.

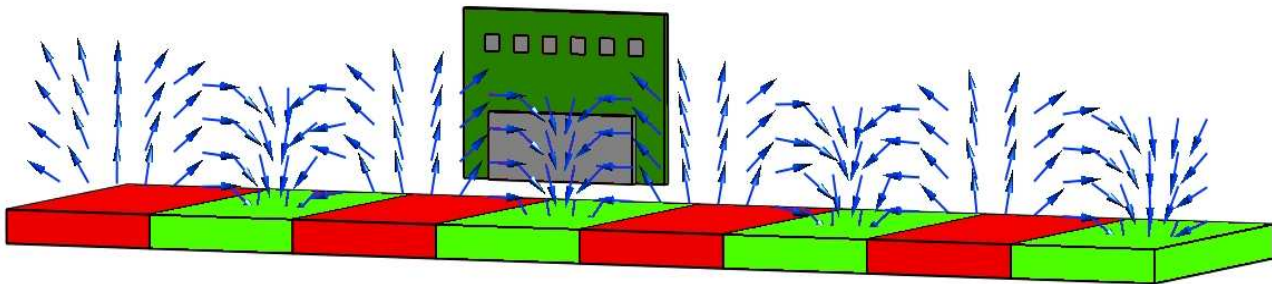

Precise displacement values will be obtained by using a sine/cosine decoder device. The maximal obtainable precision depends on the accuracy of the magnetic scale and on the distance sensor – magnetic scale. Values of <1% of the pole pitch are common.

FEATURES

- Sin- / cos-output signals suitable for signal evaluation by standard-ASIC's
- Very high precision
- Insensitive to air gap fluctuations
- Highly reliable
- Low interference field sensitivity

APPLICATIONS

- Linear displacement, movements, velocities in dirty environments
- Very precise angular measurement using pole wheels

Magnetic Length Sensor MLS (Hybrid)

SENSOR BASICS

The MLS-sensors consists of two magneto resistive Wheatstone bridges, whose resistors are placed in a way that in combination with a magnetic scale, a sine and a cosine signal is obtained. Thus, MLS sensors will only work together well with pole stripes that meet the design pole pitch. In addition, some sensor types integrate over more than one pole in order to improve sensor performance.

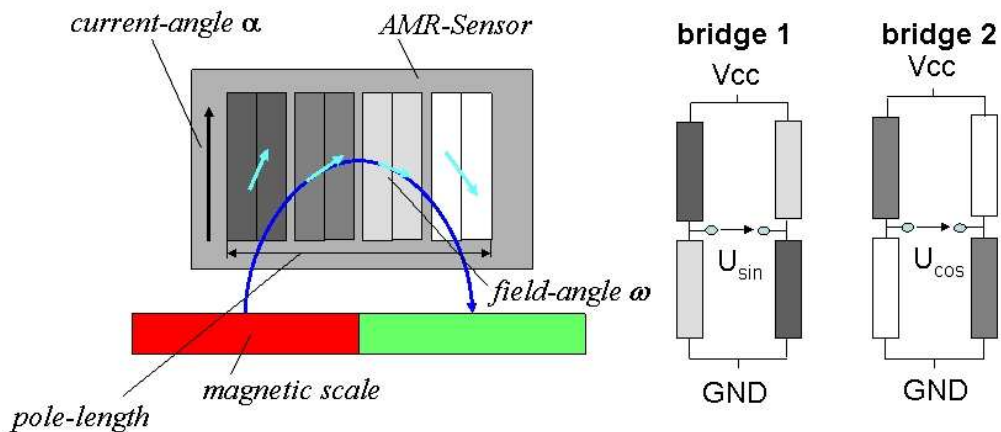

CHARACTERISTIC VALUES

PARAMETER	SYMBOL	CONDITION	TYPE	MIN	TYP	MAX	UNIT
1. Operating Limits							
max. supply voltage	$V_{cc,max}$					10	V
max. current (both bridges)	$I_{cc,max}$		MLS1000/8 MLS2000/5000			5 10	mA
operating temperature	T_{op}			-40		+85	°C
storage temperature	T_{st}			-40		+125	°C
2. Sensor Specifications (T=25 °C)							
Supply voltage	V_{cc}				5		V
pole pitch *)	p		MLS1000 MLS2000 MLS5000 MLS8		1000 2000 5000 2500		μm
Resistance (both bridges)	R_b		MLS1000 MLS2000/5000 MLS8	2000 1000 30000	3000 1500 40000	4000 2000 50000	Ω
Output signal range	$\Delta V_n/V_{cc}$	A, B		16	22		mV/V
Offset voltage	$V_{n,off}$	A, B		-1	0	+1	mV/V
3. Sensor Specifications							
TC of amplitude	TCSV	A, C			-0.35		%/K
TC of resistance	TGBR	A, C			+0.32		%/K
TC of offset	TCVoff	A, C		-4	0	+4	$\mu\text{V/V/K}$

$n = 1;2$ (bridge number); Stress above one or more of the limiting values may cause permanent damage to the device. Exposure to limiting values for extended periods may affect device reliability.

*) other pole pitches on request

Magnetic Length Sensor MLS (Hybrid)

MEASUREMENT CONDITIONS

PARAMETER	SYMBOL	UNIT	CONDITION
A. Set Up Conditions			
ambient temperature	T	°C	T = 25 °C (unless otherwise noted)
supply voltage	V _{cc}	V	V _{cc} = 5 V
applied magnetic field	H	kA/m	H > 10 kA/m
B. Sensor Specifications (T=25 °C, 360° turn , H=25 kA/m , Vo_{max}>0, Vo_{min}<0)			
output signal range	ΔV _n / V _{cc}	mV/V	ΔV _n / V _{cc} = (V _{n max} - V _{n min}) / V _{cc}
signal offset	V _{off n}	mV/V	V _{off n} = (V _{n max} + V _{n min}) / V _{cc}
C. Sensor Specifications (T=-25°C, +125°C)			
ambient temperatures	T	°C	T ₁ = -25 °C, T ₀ = +25 °C, T ₂ = +125 °C
TC of amplitude	TCSV	%/K	$TCV = \frac{1}{(T_2 - T_1)} \cdot \frac{\frac{\Delta V_n(T_2)}{V_{cc}} - \frac{\Delta V_n(T_1)}{V_{cc}}}{\frac{\Delta V_n(T_1)}{V_{cc}}} \cdot 100\%$
TC of resistance	TCBR	%/K	$TCR = \frac{1}{(T_2 - T_1)} \cdot \frac{R_n(T_2) - R_n(T_1)}{R_n(T_1)} \cdot 100\%$
TC of offset	TCVoff	μV/(VK)	$TCVoff_n = \frac{Voff_n(T_2) - Voff_n(T_1)}{(T_2 - T_1)}$

n = 1;2 (bridge number)

Magnetic Length Sensor MLS (Hybrid)

PACKAGES

HD (SMALL TWO SIDED HYBRID)

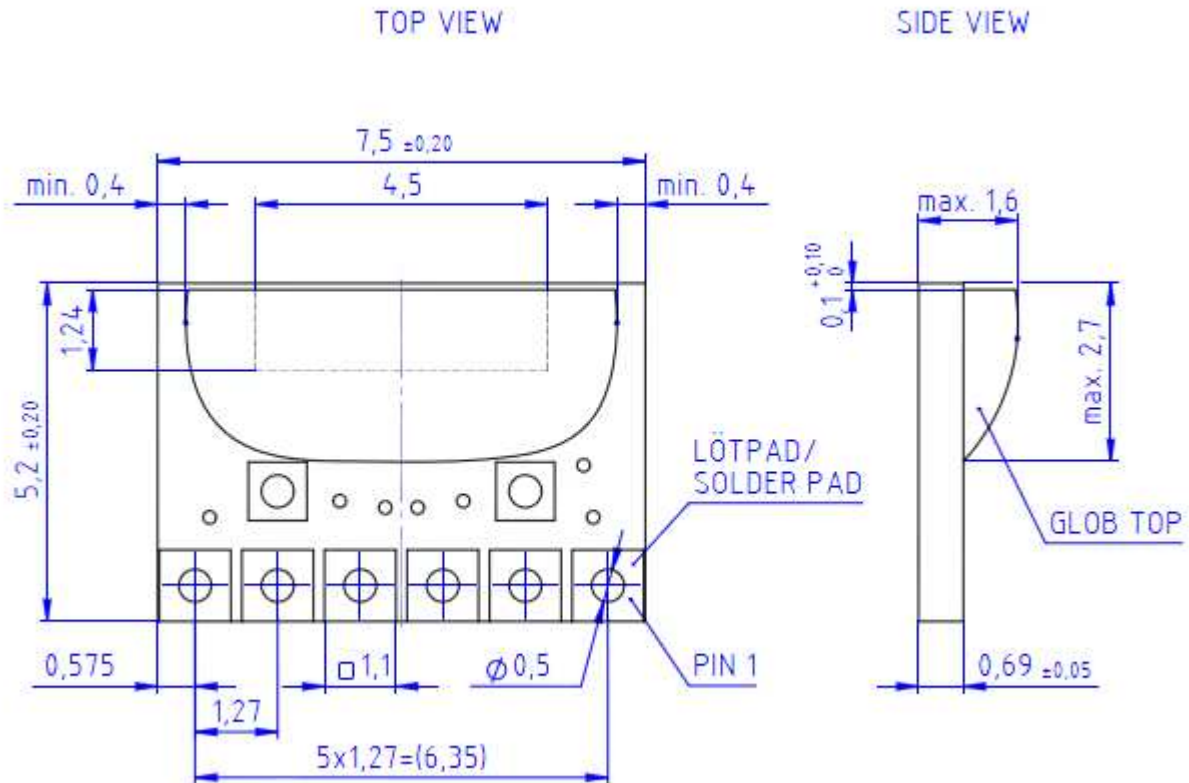

BOTTOM VIEW

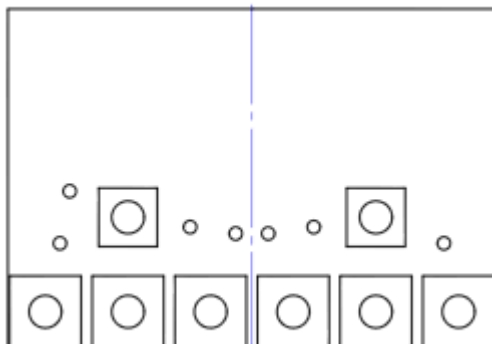

Pin	MLS1000HD	MLS2000HD	MLS5000HD	MLS8HD
1	GND	+V2	+V2	+V2
2	Vcc	Vcc	Vcc	Vcc
3	-V2	GND	GND	GND
4	+V2	+V1	+V1	+V1
5	-V1	-V1	-V1	-V2
6	+V1	-V2	-V2	-V1

Magnetic Length Sensor MLS (Hybrid)

HK (SMALL HYBRID)

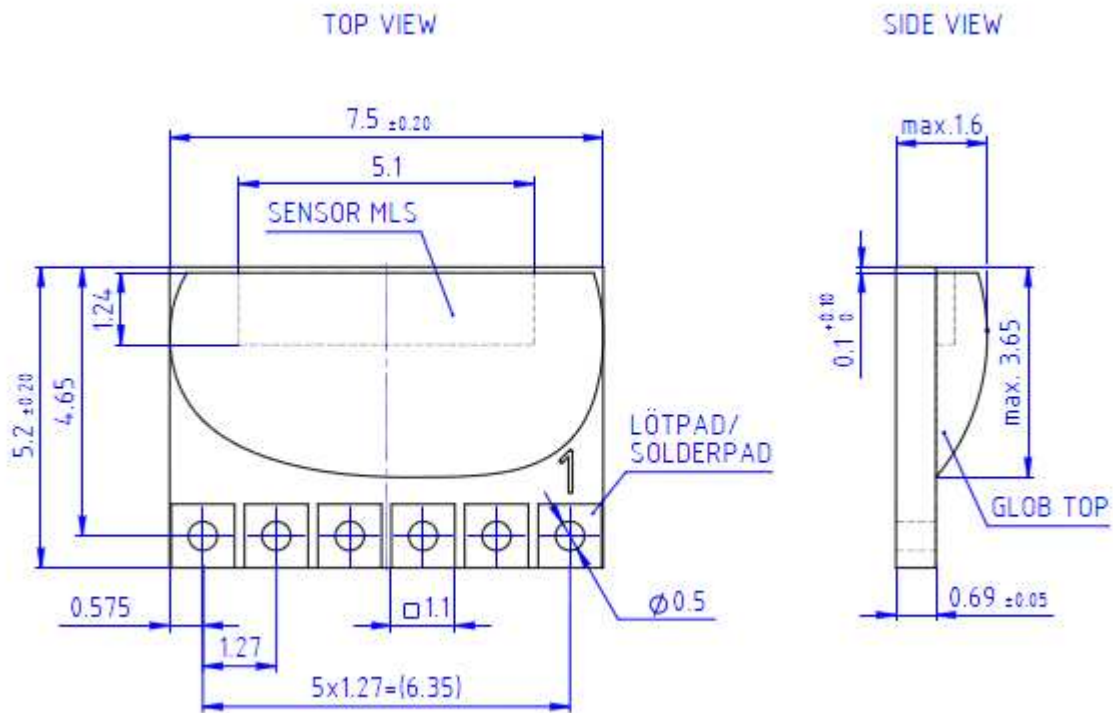

BOTTOM VIEW

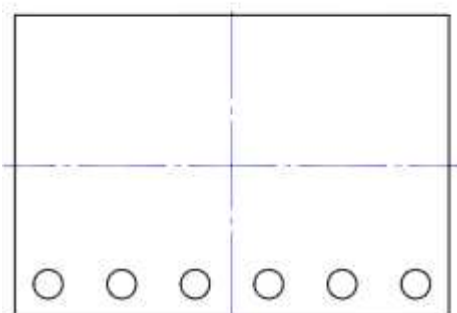

Pin	Annotation	Name
1	Output signal	V _{cos-}
2	Supply voltage	V _{cc}
3	Ground	GND
4	Output signal	V _{sin-}
5	Output signal	V _{sin+}
6	Output signal	V _{cos+}

Magnetic Length Sensor MLS (Hybrid)

HS (STANDARD HYBRID)

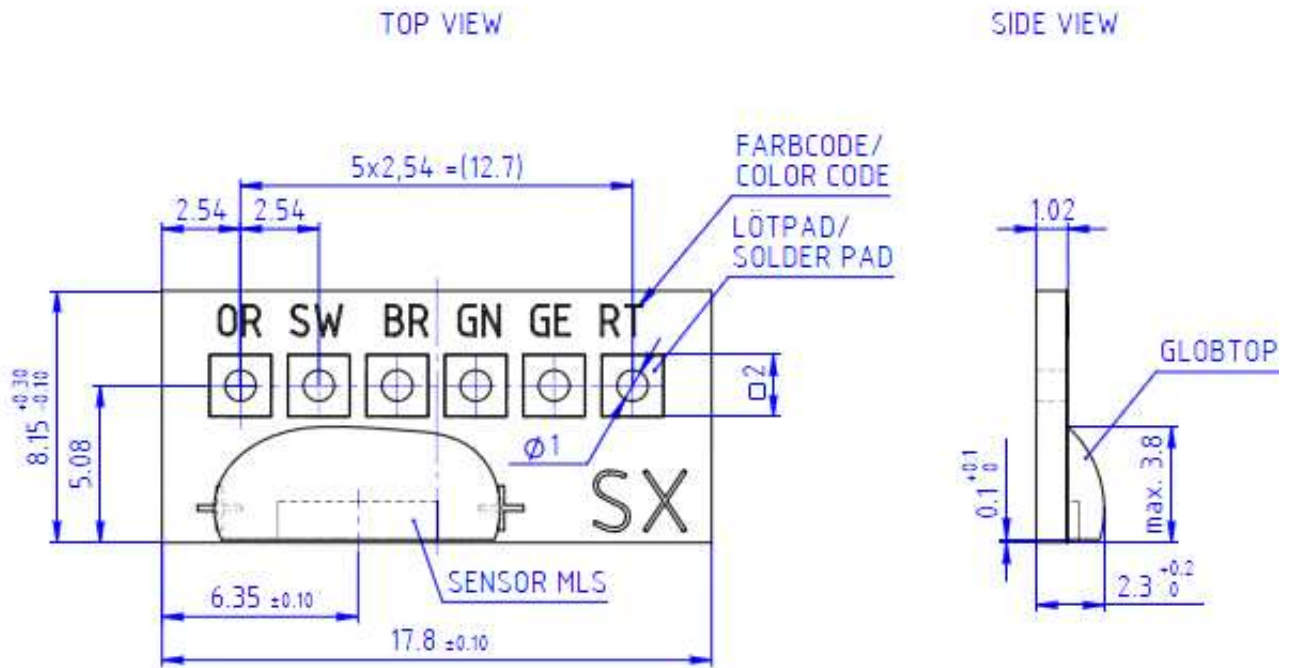

BOTTOM VIEW

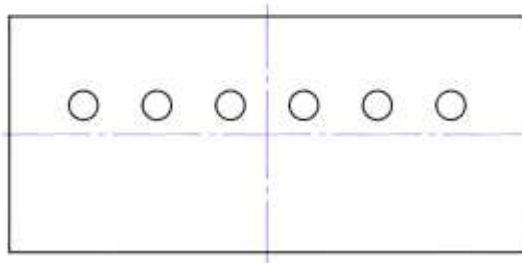

Pin	Annotation	Name
OR	Output signal	$V_{\cos-}$
SW	Supply voltage	V_{cc}
BR	Ground	GND
GN	Output signal	$V_{\sin-}$
GE	Output signal	$V_{\sin+}$
RT	Output signal	$V_{\cos+}$

Magnetic Length Sensor MLS (Hybrid)

EVALUATION KIT

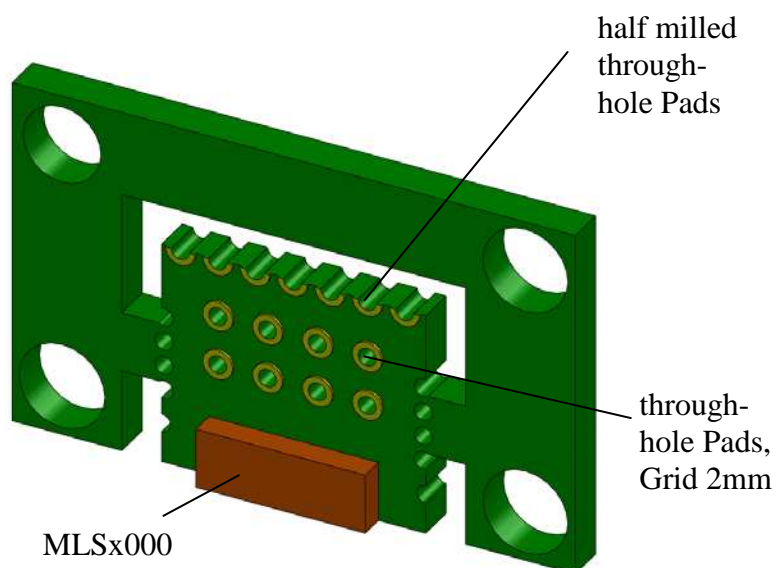
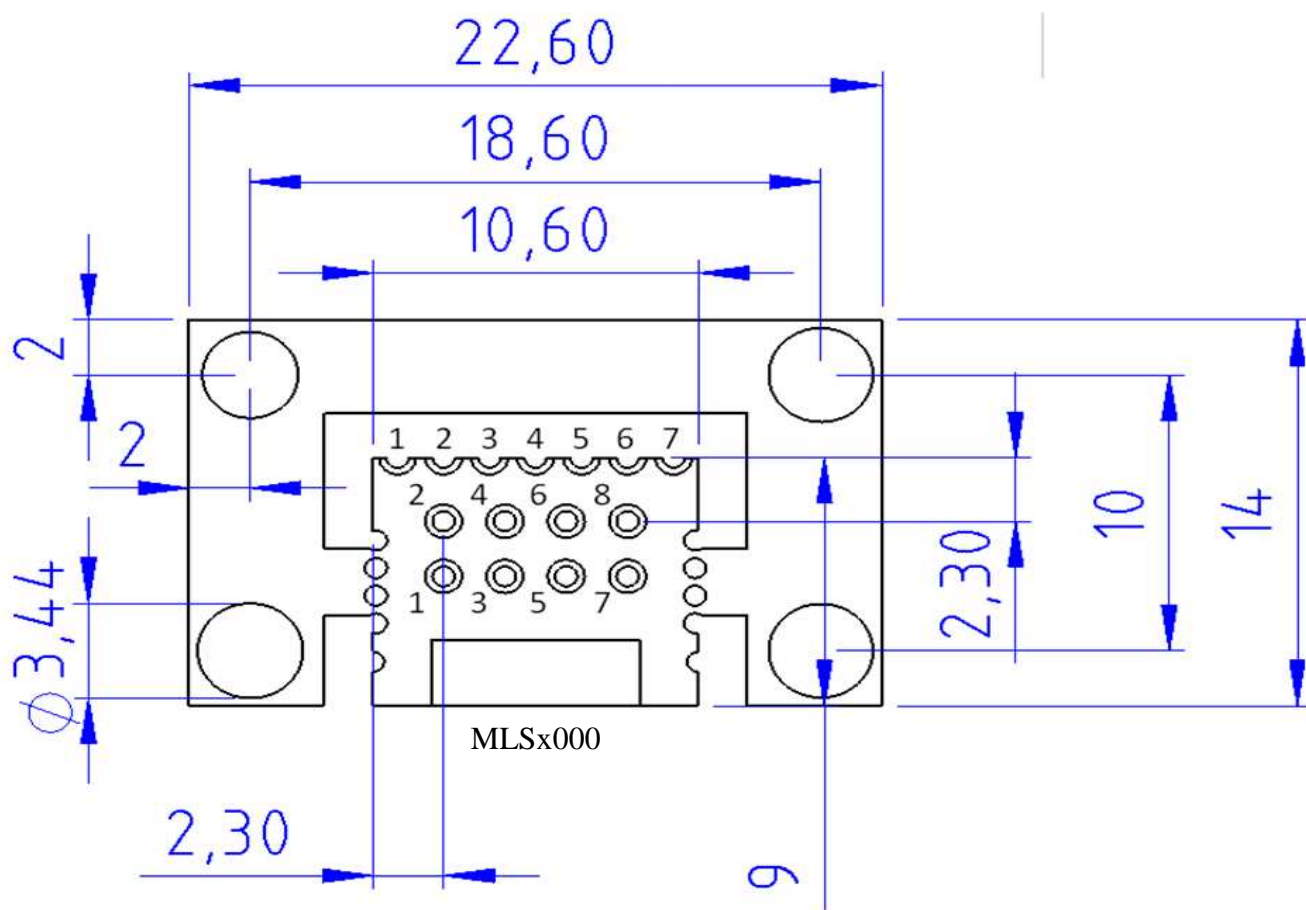

Pin	Annotation	Name
1	Ground	Gnd
2	Output signal	$V_{\cos+}$
3	Output signal	$V_{\sin+}$
4	Supply voltage	V_{cc2}
5	Output signal	$V_{\sin-}$
6	Output signal	$V_{\cos-}$
7	Supply voltage	V_{cc1}

Magnetic Length Sensor MLS (Hybrid)

APPLICATION EXAMPLE

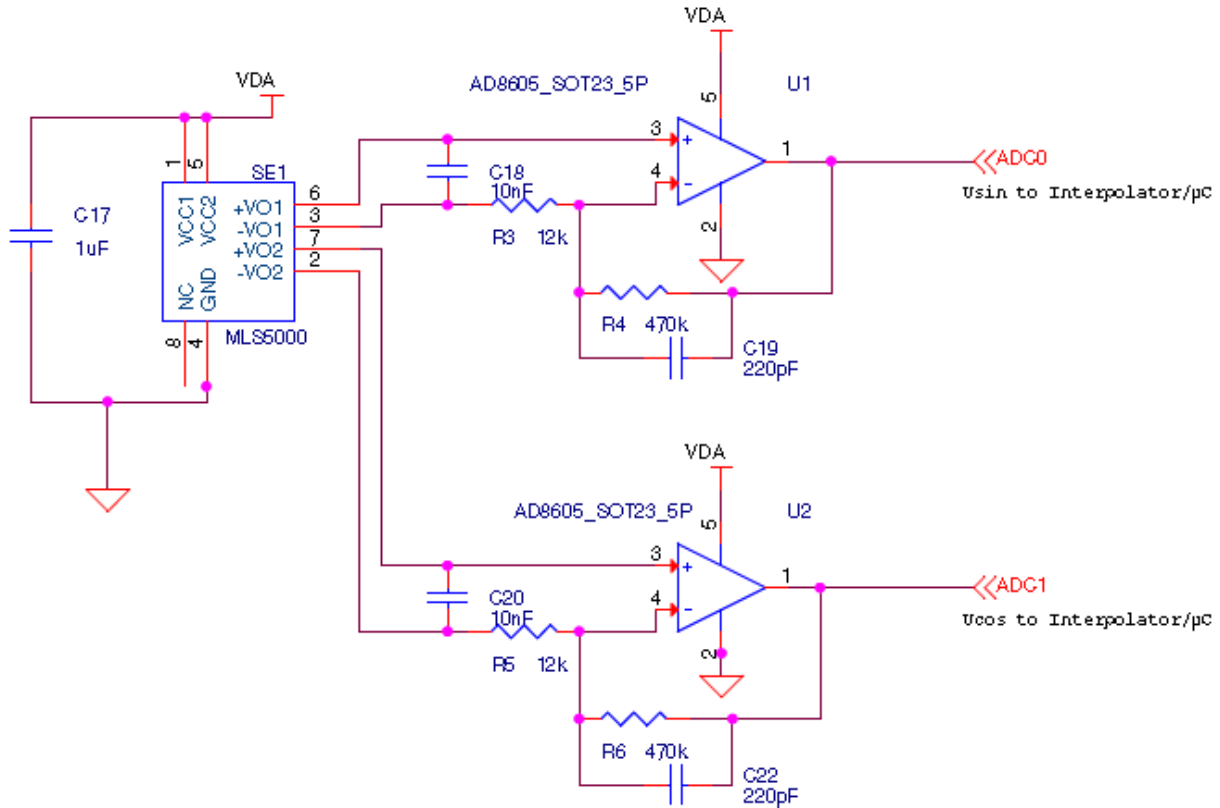

Exemplary hardware configuration using an Analog Devices AD8605 amplifier for preprocessing MLS5000 signals for usage with common Microcontroller

TEST REQUIREMENTS

The parameters of the MLS sensor are measured in combination with a magnetic scale. The magnetic scale consists of magnetic rubber material, bonded on a steel carrier. The pole pitch of the scale has to match to the sensor type (see characteristic values). MEAS can provide short strips of scales for reference.

The maximum used air gap between the sensor module and the scale has to match the sensor type and not exceed:

- MLS1000: 0.5mm
- MLS2000: 1mm
- MLS5000: 2.5mm
- MLS8: 1.25mm

Test temperature: 25°C

MEAS recommends the use of IC-Haus IC-NQ ASIC for signal evaluation.

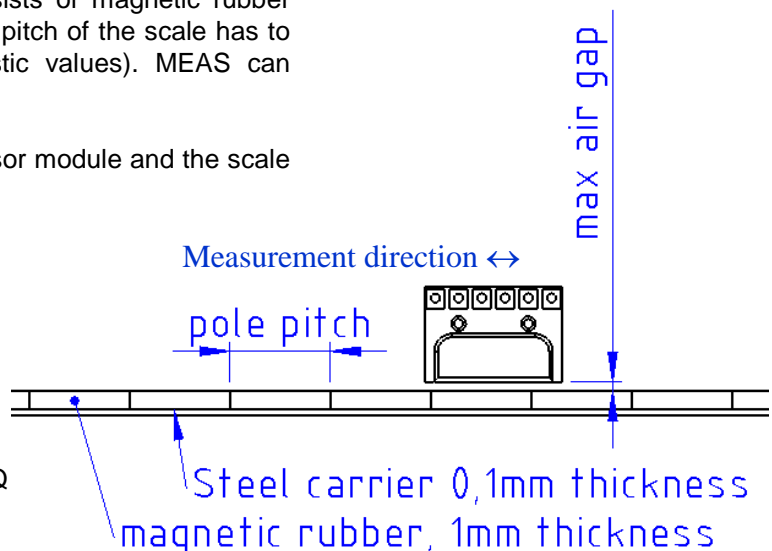

Magnetic Length Sensor MLS (Hybrid)

ORDERING CODES

	MLS1000	MLS2000	MLS5000	MLS8
Large hybrid (HS)	<i>on request</i>	<i>eng. samples</i>	G-MRCO-012	<i>eng. samples</i>
Small hybrid (HK)	<i>on request</i>	<i>eng. samples</i>	G-MRCO-013	<i>eng. samples</i>
2side hybrid (HD)	G-MRCO-038	G-MRCO-039	G-MRCO-040	G-MRCO-041

ORDERING INFORMATION

NORTH AMERICA	EUROPE	ASIA
Measurement Specialties, Inc. 1000 Lucas Way Hampton, VA 23666 United States Phone: +1-800-745-8008 Fax: +1-757-766-4297 Email: sales@meas-spec.com Web: www.meas-spec.com	MEAS Deutschland GmbH Hauert 13 D-44227 Dortmund Germany Phone: +49-(0)231-9740-0 Fax: +49-(0)231-9740-20 Email: info.de@meas-spec.com Web: www.meas-spec.com	Measurement Specialties China Ltd. No. 26, Langshan Road High-tech Park (North) Nanshan District, Shenzhen 518057 China Phone: +86-755-33305088 Fax: +86-755-33305099 Email: info.cn@meas-spec.com Web: www.meas-spec.com

The information in this sheet has been carefully reviewed and is believed to be accurate; however, no responsibility is assumed for inaccuracies. Furthermore, this information does not convey to the purchaser of such devices any license under the patent rights to the manufacturer. Measurement Specialties, Inc. reserves the right to make changes without further notice to any product herein. Measurement Specialties, Inc. makes no warranty, representation or guarantee regarding the suitability of its product for any particular purpose, nor does Measurement Specialties, Inc. assume any liability arising out of the application or use of any product or circuit and specifically disclaims any and all liability, including without limitation consequential or incidental damages. Typical parameters can and do vary in different applications. All operating parameters must be validated for each customer application by customer's technical experts. Measurement Specialties, Inc. does not convey any license under its patent rights nor the rights of others.