

# V-Series Inclinometer



- Single or dual axis inclinometer
- Measurement range  $\pm 5^\circ$   $\pm 15^\circ$  and  $\pm 45^\circ$
- analogue voltage or current output signal
- AL-housing IP 65

## DESCRIPTION

The **V-Series** of conductive single or dual axis inclinometers offers a modern electronic in an environmentally protected and robust aluminium anodizing housing. This fully calibrated inclinometer is available with an analogue voltage output signals or current output signal. They have a compact study design and show large range of applications are possible.

## FEATURES

- Single or dual axis inclinometer
- Analogue voltage or current output signal
- Easy to mounted
- High resolution
- Protection class IP 65
- Rugged M9 7 pins connector
- Robust AL-housing

## APPLICATIONS

- Drilling machines
- Vehicle applications
- Building control
- Mobile and stationary cranes
- Hydraulic leveling
- Platform leveling
- Road construction machines

# V-Series Inclinator

## PERFORMANCE SPECIFICATIONS

|  | Conditions      | Min                              | Type | Max           | Unit  |
|--|-----------------|----------------------------------|------|---------------|-------|
| Measurement range                        |                 | -5 / -15/ -45                    |      | +5 / +15/ +45 | °     |
| Resolution <sup>(1)</sup>                |                 | 0.001                            |      | 0.01          | °     |
| Accuracy                                 | Ta = 0°...70°C, | 0.08 / 0.15 / 0.9 <sup>(4)</sup> |      |               | °     |
| Non-linearity                            |                 | 1.5                              |      |               | %[FS] |
| Cross sensitivity                        |                 | 0.15                             |      |               | %[FS] |
| Voltage output signal <sup>(2),(3)</sup> | V,V2 unit       | -2                               |      | +2            | V     |
| Voltage output signal <sup>(3)</sup>     | V,V2 unit       | 0.5                              |      | 4.5           | V     |
| Current output signal <sup>(3)</sup>     | VI,V2I unit     | 20                               |      | 4             | mA    |
| Current consumption                      |                 | 10                               |      | 30            | mA    |
| Power supply                             |                 | +12                              |      | +24           | VDC   |
| Operation temperature range              |                 | 0                                |      | +70           | °C    |
| Storage temperature range                |                 | -40                              |      | +85           | °C    |
| Weight                                   |                 | 300                              |      | 320           | g     |
| Dimensions                               | W x D x H       | 90 x 60 x 45.5                   |      |               | mm    |

- (1) depend on measurement range
- (2) ratiometric to signal ground GNDx,y
- (3) depending on the circuitry wiring, see pinning schema
- (4) up to measurement range +/-30°

# V-Series Inclinometer

## DIMENSIONS [MM]

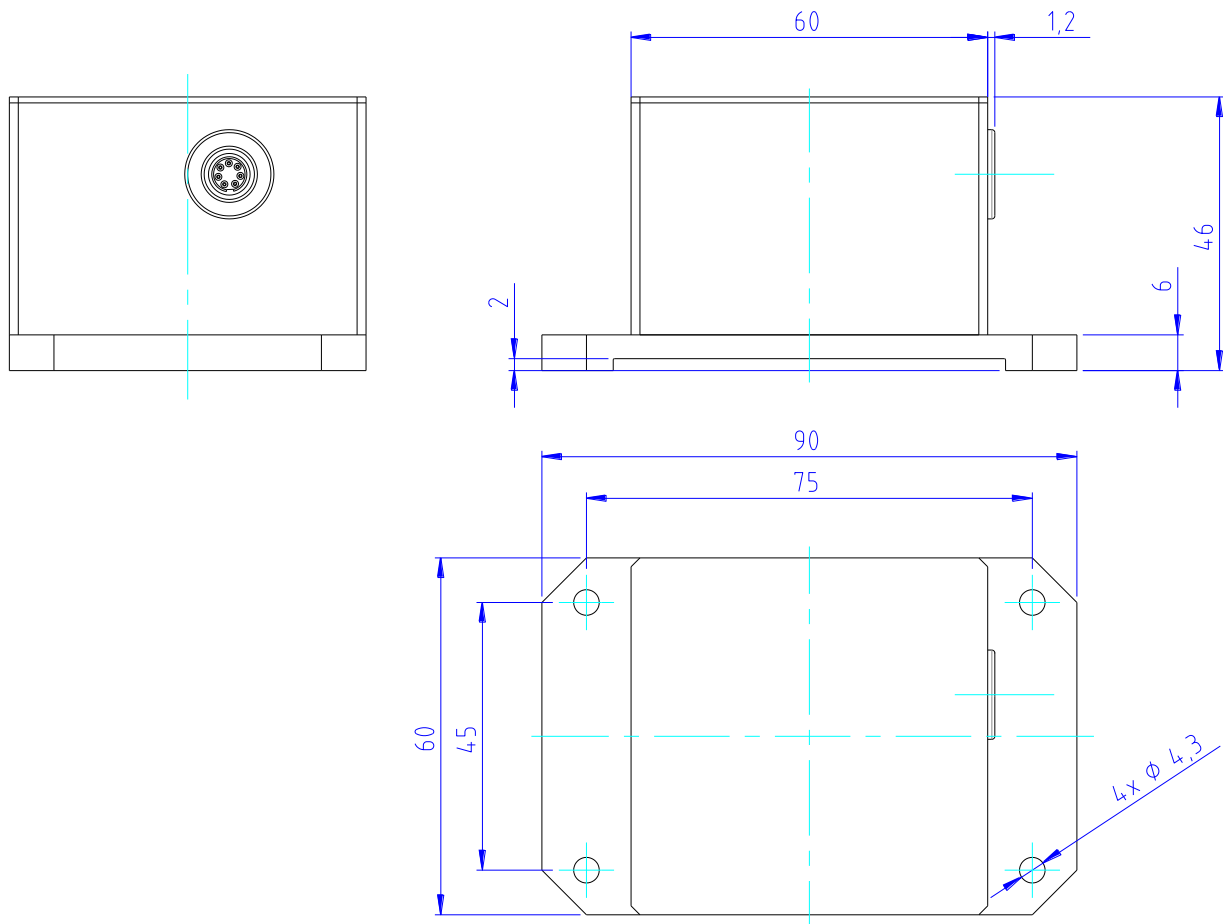

# V-Series Inclinometer

## PINNING

Pinning single axis unit with voltage output signal: NS-5/V, NS-15/V, NS-45/V

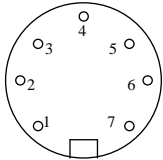

| Pin | Name   | Description                             | Type          | Color schema(1) |
|-----|--------|---|---------------|-----------------|
| 1   | Vcc    | Positive power supply +12...+24VDC      | Supply, Input | white           |
| 2   | GND    | Ground, negative supply voltage         | Supply, Input | brown           |
| 3   | Earth  | Protection conductor                    | Supply, Input | green           |
| 4   | GNDx   | Ground for output voltage signal X axis | Output        | yellow          |
| 5   | n.c.   | n.c.                                    | -             | grey            |
| 6   | Out Vx | Output voltage signal X axis            | Output        | pink            |
| 7   | n.c.   | n.c.                                    | -             | blue            |

(1) by using a Measurement Specialties cable

### Output connecting possibility 1

Pin 6 output voltage signal Vx x-axis



Output signal – 2V ( - 5°) up to +2V ( + 5°)

Output signal – 2V (-15°) up to +2V (+15°)

Output signal – 2V (-45°) up to +2V (+45°)

Pin 4 GNDx analogue ground x-axis

### Output connecting possibility 2

Pin 6 output voltage signal Vx x-axis



Output signal + 0,5V ( - 5°) up to + 4,5V ( + 5°)

Output signal + 0,5V (-15°) up to + 4,5V (+15°)

Output signal + 0.5V (-45°) up to + 4,5V (+45°)

Pin 2 GND supply ground

Pinning single axis unit with current output signal: NS-5/VI, NS-15/VI, NS-45/VI

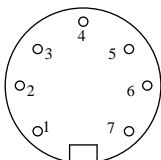

| Pin | Name   | Description                             | Type          | Color schema(1) |
|-----|--------|---|---------------|-----------------|
| 1   | Vcc    | Positive power supply +12...+24VDC      | Supply, Input | white           |
| 2   | GND    | Ground, negative supply voltage         | Supply, Input | brown           |
| 3   | Earth  | Protection conductor                    | Supply, Input | green           |
| 4   | GNDx   | Ground for output current signal X axis | Output        | yellow          |
| 5   | n.c.   | n.c.                                    | -             | grey            |
| 6   | Out Ix | Output Current signal X axis            | Output        | pink            |
| 7   | n.c.   | n.c.                                    | -             | blue            |

(1) by using a Measurement Specialties cable

# V-Series Inclinometer

**Pinning dual axis unit with voltage output signal: NS-5/V2, NS-15/V2, NS-45/V2**

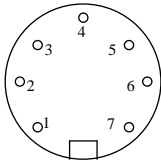

| Pin | Name   | Description                             | Type          | Color schema(1) |
|-----|--------|---|---------------|-----------------|
| 1   | Vcc    | Positive power supply +12...+24VDC      | Supply, Input | white           |
| 2   | GND    | Ground, negative supply voltage         | Supply, Input | brown           |
| 3   | Earth  | Protection conductor                    | Supply, Input | green           |
| 4   | GNDx   | Ground for output voltage signal X axis | Output        | yellow          |
| 5   | GNDy   | Ground for output voltage signal Y axis | Output        | grey            |
| 6   | Out Vx | Output voltage signal X axis            | Output        | pink            |
| 7   | Out Vy | Output voltage signal Y axis            | Output        | blue            |

(1) by using a Measurement Specialties cable

## Output connecting possibility 1

Pin 6,7 output voltage signal Vx x-axis, Vy y-axis



Pin 4,5 GNDx,y analogue ground x,y-axis

Output signal – 2V ( - 5°) up to +2V ( + 5°)

Output signal – 2V (-15°) up to +2V (+15°)

Output signal – 2V (-45°) up to +2V (+45°)

## Output connecting possibility 2

Pin 6,7 output voltage signal Vx x-axis, Vy y-axis



Pin 2 GND supply ground

Output signal + 0,5V ( - 5°) up to + 4,5V ( + 5°)

Output signal + 0,5V (-15°) up to + 4,5V (+15°)

Output signal + 0.5V (-45°) up to + 4,5V (+45°)

**Pinning dual axis unit with current output signal: NS-5/V2I, NS-15/V2I, NS-45/V2I**

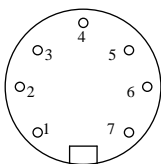

| Pin | Name   | Description                             | Type          | Color schema(1) |
|-----|--------|---|---------------|-----------------|
| 1   | Vcc    | Positive power supply +12...+24VDC      | Supply, Input | white           |
| 2   | GND    | Ground, negative supply voltage         | Supply, Input | brown           |
| 3   | Earth  | Protection conductor                    | Supply, Input | green           |
| 4   | GNDx   | Ground for output current signal X axis | Output        | yellow          |
| 5   | GNDy   | Ground for output current signal Y axis | Output        | grey            |
| 6   | Out Ix | Output Current signal X axis            | Output        | pink            |
| 7   | Out Iy | Output Current signal Y axis            | Output        | blue            |

(1) by using a Measurement Specialties cable

# V-Series Inclinometer

## ORDERING INFORMATION

| PART NUMBERING          | UNIT       | SHORT DESCRIPTION                                 |
|-------------------------|------------|---|
| <b>Single axis unit</b> |            |   |
| G-NSV-001               | NS- 5/V    | single axis,range +/- 5°,Vcc 12...24VDC,output V  |
| G-NSVI-001              | NS- 5/VI   | single axis,range +/- 5°,Vcc 12...24VDC,output I  |
| G-NSV-002               | NS-15/V    | single axis,range +/--15°,Vcc 12...24VDC,output V |
| G-NSVI-003              | NS-15/VI   | single axis,range +/--15°,Vcc 12...24VDC,output I |
| G-NSV-005               | NS-45/V    | single axis,range +/--45°,Vcc 12...24VDC,output V |
| G-NSVI-006              | NS-45/VI   | single axis,range +/--45°,Vcc 12...24VDC,output I |
| <b>Dual axis unit</b>   |            |   |
| G-NSV2-001              | NS- 5/V2   | dual axis,range +/- 5°,Vcc 12...24VDC,output V    |
| G-NSV2I-001             | NS- 5/V2I  | dual axis,range +/- 5°,Vcc 12...24VDC,output I    |
| G-NSV2-003              | NS-15/V2   | dual axis,range +/--15°,Vcc 12...24VDC,output V   |
| G-NSV2I-003             | NS-15/V2I  | dual axis,range +/--15°,Vcc 12...24VDC,output I   |
| G-NSV2-006              | NS-45/V2   | dual axis,range +/--45°,Vcc 12...24VDC,output V   |
| G-NSV2I-006             | NS-45/V2I  | dual axis,range +/--45°,Vcc 12...24VDC,output I   |
| <b>Accessories</b>      |            |   |
| G-NSMIS-001             | Connection | Connector,straight, Submin. 712-series            |
| G-NSMIS-015             | Connection | Connector, angle 90°, Submin. 712-series          |
| G-NSMIS-002             | Connection | 2 m cable, straight connector Submin. 702-series  |
| G-NSMIS-003             | Connection | 2 m cable, angle 90° connector Submin. 702-series |

Other cable length on request

| NORTH AMERICA   | EUROPE   | ASIA  |
|---|--|---|
| Measurement Specialties, Inc.<br>1000 Lucas Way<br>Hampton, VA 23666<br>United States<br>Phone: +1-800-745-8008<br>Fax: +1-757-766-4297<br>Email: <a href="mailto:sales@meas-spec.com">sales@meas-spec.com</a><br>Web: <a href="http://www.meas-spec.com">www.meas-spec.com</a> | MEAS Deutschland GmbH<br>Hauert 13<br>D-44227 Dortmund<br>Germany<br>Phone: +49-(0)231-9740-0<br>Fax: +49-(0)231-9740-20<br>Email: <a href="mailto:info.de@meas-spec.com">info.de@meas-spec.com</a><br>Web: <a href="http://www.meas-spec.com">www.meas-spec.com</a> | Measurement Specialties China Ltd.<br>No. 26, Langshan Road<br>High-tech Park (North)<br>Nanshan District, Shenzhen 518057<br>China<br>Phone: +86-755-33305088<br>Fax: +86-755-33305099<br>Email: <a href="mailto:info.cn@meas-spec.com">info.cn@meas-spec.com</a><br>Web: <a href="http://www.meas-spec.com">www.meas-spec.com</a> |

The information in this sheet has been carefully reviewed and is believed to be accurate; however, no responsibility is assumed for inaccuracies. Furthermore, this information does not convey to the purchaser of such devices any license under the patent rights to the manufacturer. Measurement Specialties, Inc. reserves the right to make changes without further notice to any product herein. Measurement Specialties, Inc. makes no warranty, representation or guarantee regarding the suitability of its product for any particular purpose, nor does Measurement Specialties, Inc. assume any liability arising out of the application or use of any product or circuit and specifically disclaims any and all liability, including without limitation consequential or incidental damages. Typical parameters can and do vary in different applications. All operating parameters must be validated for each customer application by customer's technical experts. Measurement Specialties, Inc. does not convey any license under its patent rights nor the rights of others.