



- Disposable Blood Pressure Sensor
- AAMI Specifications
- Low Cost Disposable
- Dielectric Gel Barrier
- Fully Tested & Calibrated

DESCRIPTION

The 1620 is a fully piezoresistive silicon pressure sensor for use in invasive blood pressure monitoring. The sensor is designed to be used with automated assembly equipment and can be dropped directly into a customer's disposable blood pressure housing. The sensor is designed to meet the requirements as described in the Association for the Advancement of Medical Instrumentation (AAMI) specification for Blood Pressure Transducers.

The pressure sensor consists of a pressure sensing element mounted on a ceramic substrate. Thick film resistors on the ceramic substrate are laser trimmed for compensation and calibration. A plastic cap is attached to the ceramic substrate to provide an easy method of attachment to the customer's assembly and protection for the sensing element. A dielectric gel is placed over the sensor to provide electrical and fluid isolation.

The 1620 pressure sensors are batch manufactured in a 10x12 element array on a ceramic substrate (120 units per substrate). The products are shipped in anti-static shipping containers. They can also be shipped on a tape and reel. Performance characteristics and packaging can be easily tailored on a special order basis to meet the requirements of specific customers.

FEATURES

- Low Cost, Medical Applications
- Small Size and Reliable Performance
- Gel Isolation for Liquids
- Operates from 5°C to 40°C
- Compatible for Automated Assembly
- 1% Accuracy for Replacements
- 5.0 uV/V/mmHg Sensitivity
- Customization for OEM Applications

APPLICATIONS

- Surgical Procedures
- Intensive Care Units
- Infusion Pumps
- Kidney Dialysis Machines
- Vacuum Assisted Birth
- Intrauterine Monitoring

STANDARD RANGES

Range	mmHg
-50 to 300	•

PERFORMANCE SPECIFICATIONS

Supply Voltage: 6.0 Vdc

Ambient Temperature: 23°C (unless otherwise specified)

PARAMETERS	MIN	TYP	MAX	UNITS	NOTES
Operating Pressure Range	-50		300	mmHg	
Over Pressure	125			psi	
Zero Pressure Offset	-20		20	mmHg	
Sensitivity	4.95	5.00	5.05	uV/V/mmHg	
Calibration	97.5	100	102.5	mmHg	1
Linearity and Hysteresis (-30 to 100 mmHg)	-1		1	mmHg	2
Linearity and Hysteresis (100 to 200 mmHg)	-1		1	% Output	2
Linearity and Hysteresis (200 to 300 mmHg)	-1.5		1.5	% Output	2
Input Impedance	1200		3200	Ω	
Output Impedance	285		315	Ω	
Output Symmetry	0.95		1.05	Ratio	3
Supply Voltage	2	6	10	Vdc or Vac rms	
Risk Current (@ 120 Vac rms, 60Hz)			2	uA	
Warm-Up Time		5		Seconds	
Frequency Response		1200		Hz	
Offset Drift			2	mmHg	4
Thermal Span Shift	-0.1		0.1	%/°C	5
Thermal Offset Shift	-0.3		0.3	mmHg/°C	5
Phase Shift (@ 5KHz)			5	Degrees	
Light Sensitivity (3000 Foot Candle)		1		mmHg	
Defibrillator withstand (400 joules)	5			Discharges	6
Sterilization (ETO)	3			Cycles	7
Operating Temperature	5		40	°C	
Storage Temperature	-25		+70	°C	
Humidity (External)	10-90% (non-condensing)				
Operating Product Life	168 Hours				
Shelf Life	5 Years				
Dielectric Breakdown	10,000Vdc				
Media Interface	Dielectric Gel				
Volume Displacement	4.5 x 10 ⁻⁴ mm ³				
Weight	0.5 grams				

Notes

1. Output of sensor with no pressure applied and a 150K Ohms resistor placed across +SUPPLY to +OUTPUT.
2. Best fit straight line.
3. Defined as common mode symmetry between any output and supply terminal.
4. Over an 8 hour time period after a 10 minute warm-up.
5. Over operating temperature range 10-40°C with respect to 23°C.
6. One discharge per minute performed by customer.
7. Sterilization performed by customer.
8. This model is not suitable for surface mount operation.

DIMENSIONS

ALL DIMENSIONS ARE IN INCHES [Millimeters]

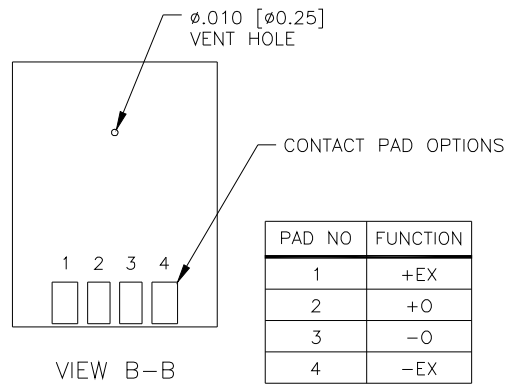
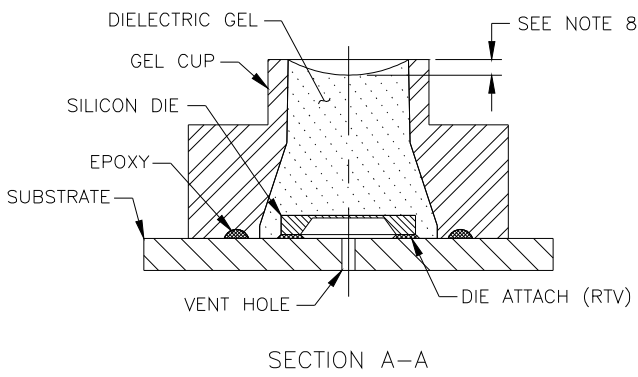
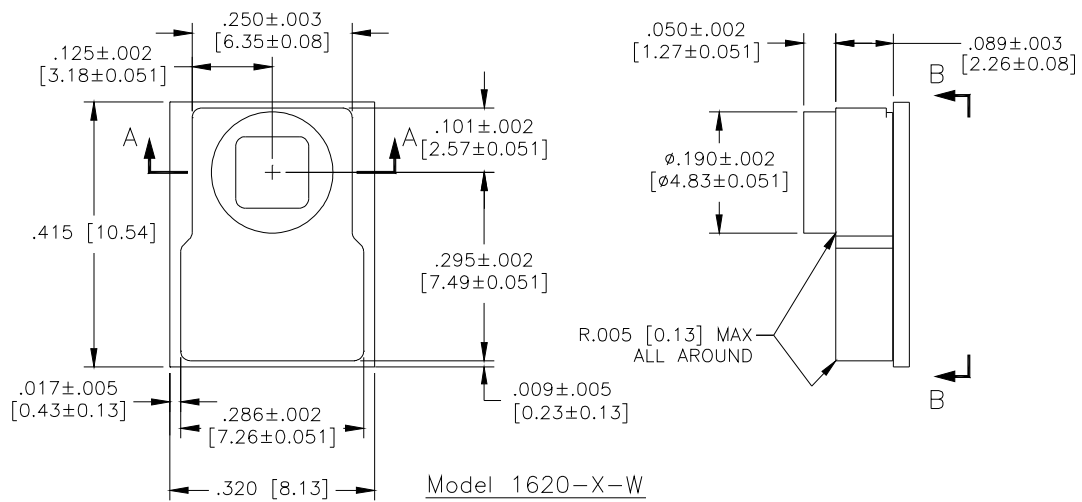
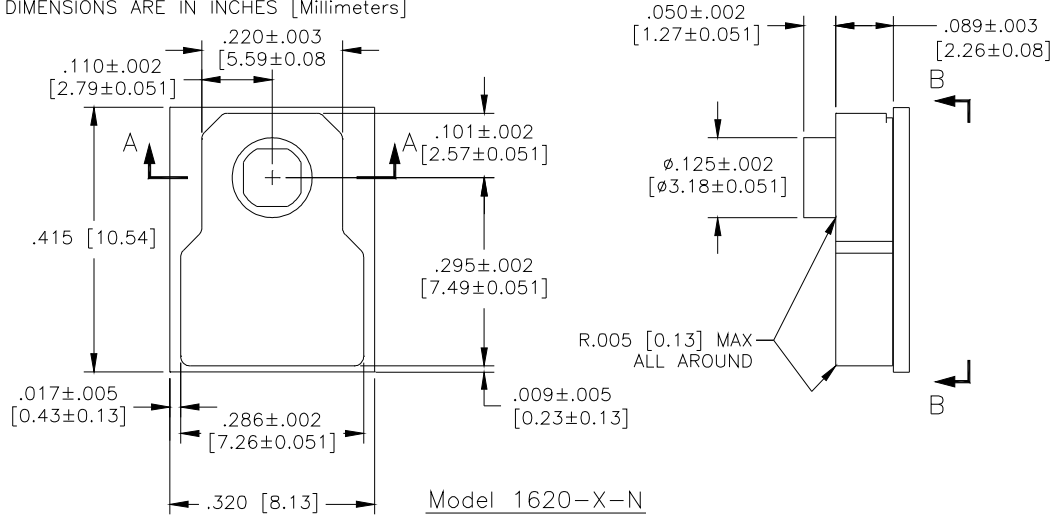

*Dimensions indicated to not include flares.

SHIPPING INFORMATION

SHIPPING CONFIGURATION OPTION: TAPE AND REEL

TAPE SPECIFICATIONS
1/2 SCALE

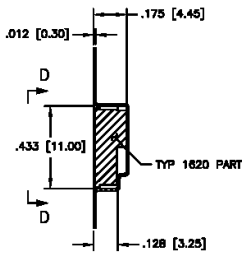
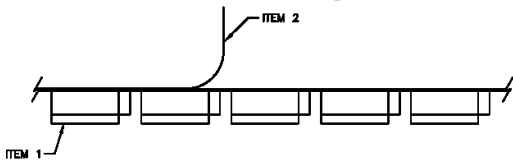
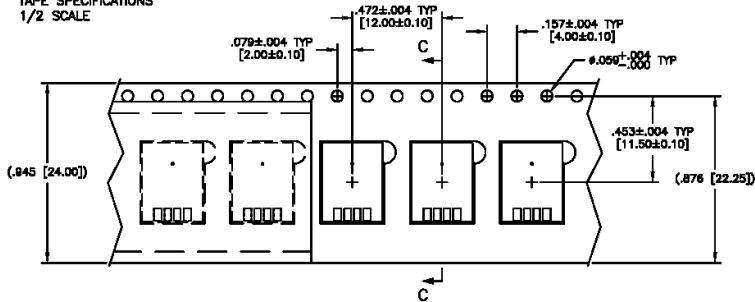

SECTION C-C
SCALE: 2X

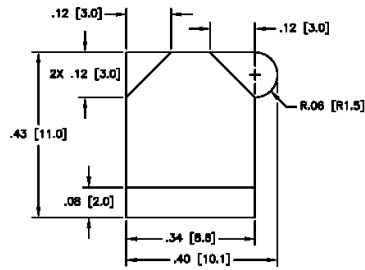

VIEW D-D
SCALE: 4X
SHOWN WITHOUT PART
FOR CLARITY

REEL SPECIFICATIONS
1/8 SCALE

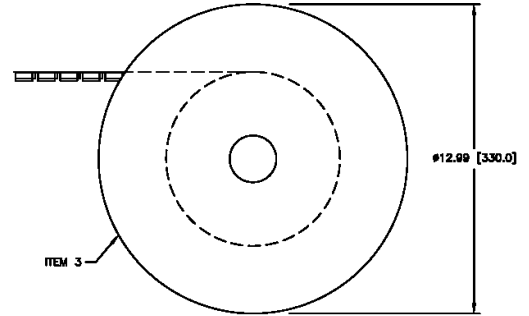

TAPE AND REEL INFO

A) MATERIAL:

- ITEM 1, CARRIER TAPE: POLYCARBONATE
- ITEM 2, COVER TAPE: POLYCARBONATE, HEAT PRESSURE SEAL
- ITEM 3, PACKAGING TRAY: PLASTIC

B). TOTAL PEEL STRENGTH SHOULD BE 10 TO 130 GRAMS.

C). REFERENCE DOC: ANSI/EIA-481-C: 8mm THROUGH 200mm EMBOSSED CARRIER TAPING; 8mm AND 12mm PUNCHED CARRIER TAPING OF SURFACE MOUNT COMPONENTS FOR AUTOMATIC HANDLING.

STANDARD PAD CONFIGURATIONS

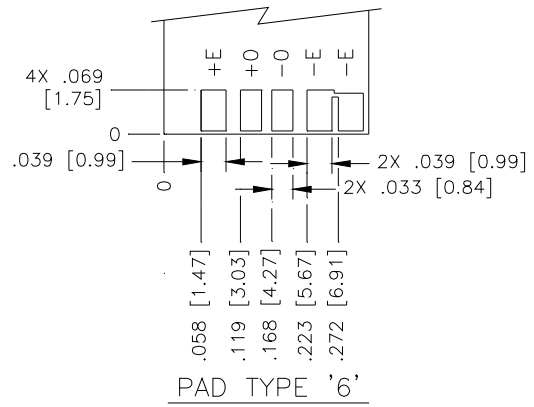
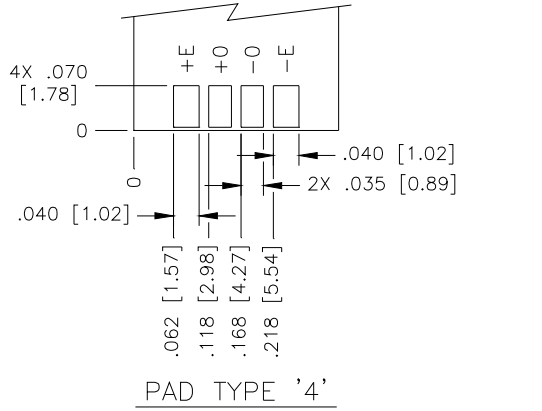

CONNECTIONS

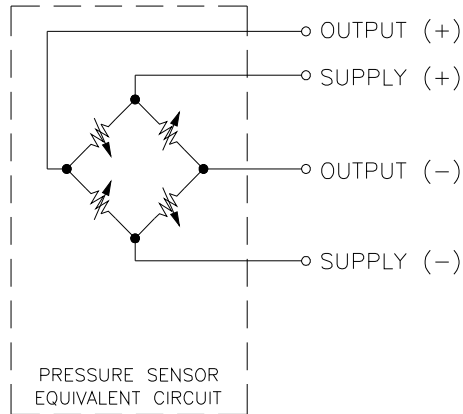

ORDERING INFORMATION

1620 - 4 - N - T

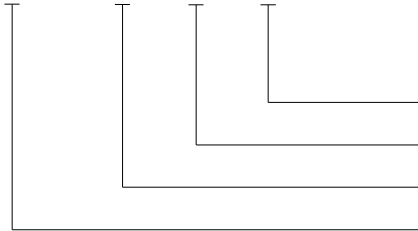

Shipping (T = Tape and Reel)
Body Style (N = Narrow, W = Wide)
Pad Configuration (4, 6)
Model

NORTH AMERICA

Measurement Specialties
45738 Northport Loop West
Fremont, CA 94538
Tel: 1-800-767-1888
Fax: 1-510-498-1578
Sales: pfg.cs.amer@meas-spec.com

EUROPE

Measurement Specialties
(Europe), Ltd.
26 Rue des Dames
78340 Les Clayes-sous-Bois, France
Tel: +33 (0) 130 79 33 00
Fax: +33 (0) 134 81 03 59
Sales: pfg.cs.emea@meas-spec.com

ASIA

Measurement Specialties
(China), Ltd.
No. 26 Langshan Road
Shenzhen High-Tech Park (North)
Nanshan District, Shenzhen 518057
China
Tel: +86 755 3330 5088
Fax: +86 755 3330 5099
Sales: pfg.cs.asia@meas-spec.com

The information in this sheet has been carefully reviewed and is believed to be accurate; however, no responsibility is assumed for inaccuracies. Furthermore, this information does not convey to the purchaser of such devices any license under the patent rights to the manufacturer. Measurement Specialties, Inc. reserves the right to make changes without further notice to any product herein. Measurement Specialties, Inc. makes no warranty, representation or guarantee regarding the suitability of its product for any particular purpose, nor does Measurement Specialties, Inc. assume any liability arising out of the application or use of any product or circuit and specifically disclaims any and all liability, including without limitation consequential or incidental damages. Typical parameters can and do vary in different applications. All operating parameters must be validated for each customer application by customer's technical experts. Measurement Specialties, Inc. does not convey any license under its patent rights nor the rights of others.