

M7100 Pressure Transducer



- Performance standard on and off highway engine and vehicle OEMs
- Rugged for heavy equipment and outdoor use
- Designed specifically for high volume applications
- Stainless Steel wetted surfaces
- Medium to extremely high pressures
- CE Approved
- UL Certified
- Gage and no-vent gage

DESCRIPTION

The M7100 pressure transducer from the Microfused™ line of MEAS sets a new price performance standard for demanding engine and vehicle, and industrial applications. This transducer is suitable for measurement of liquid or gas pressure, even for difficult media such as contaminated water, steam and corrosive fluids.

The transducer pressure cavity is machined from a solid piece of 17-4 PH stainless steel. The standard version includes a 1/4 NPT pipe thread allowing a leak-proof, all metal sealed system. There are no O-rings or organics exposed to the pressure media and the durability is excellent. This automotive grade pressure transducer with stainless steel hermetic pressure ports and integral electrical connector can boast up to 43,000psi (3000Bar). The M7100 is UL certified and exceeds the latest industrial CE requirements including surge protection and is overvoltage protected in both positive and reverse polarity.

FEATURES

- Hermetic Pressure Ports
- Integral Electrical Connector
- Survives High Vibration
- ±0.25% Accuracy
- Water Resistant 1M Immersion

APPLICATIONS

- On and Off Highway Engines and Vehicles
- HVAC Refrigeration Controls
- Compressors
- Hydraulics
- Energy and Water Management

STANDARD RANGES

Range	psiG	psiN	Range	BarG	BarN
0 to 150	•	•	0 to 010	•	•
0 to 200	•	•	0 to 014	•	•
0 to 300	•	•	0 to 020	•	•
0 to 500	•	•	0 to 035	•	•
0 to 01K	•	•	0 to 070	•	•
0 to 1K5	•	•	0 to 100	•	•
0 to 03K		•	0 to 200		•
0 to 05K		•	0 to 350		•
0 to 7K5		•	0 to 500		•
0 to 10K		•	0 to 700		•

For other pressure ranges, please consult factory.

M7100 Pressure Transducer

PERFORMANCE SPECIFICATIONS

Supply Voltage: 5V

Ambient Temperature: 25°C (unless otherwise specified)

PARAMETERS	MIN	TYP	MAX	UNITS	NOTES
Load Resistance	10			KΩ	
Accuracy (combined linearity, hysteresis & repeatability)	-0.25		0.25	%Span	1
Total Error Band	-1.0		1.0	%Span	2
Compensated Temperature	-20		+85	°C	
Operating Temperature	-40		+125	°C	3
Storage Temperature	-50		+125	°C	
Insulation Resistance (500Vdc)	100			MΩ	4
Short Circuit Protected		Yes			
Output Noise @ 1kHz		10		mV	
Long Term Stability	-0.25		0.25	%Span/Year	
Frequency Response @ -3dB		1		KHz	

Notes

1. Best fit straight line.
2. Over the compensated temperature range.
3. Transducer is functional, accuracy specified not guaranteed.
4. Between sensor body to any pins of connector.

ENVIRONMENTAL SPECIFICATIONS

Supply Voltage: 5V

Ambient Temperature: 25°C (unless otherwise specified)

PARAMETERS	MIN	TYP	MAX	UNITS	NOTES
Humidity (@40°C)			93	%RH	
Pressure Overload			2X	Rated	5
Pressure Burst			5X	Rated	6
Pressure Cycle	10M			Cycles	
Media, Pressure Port	Fluids compatible with 17-4PH Stainless Steel				
Mechanical Vibration	20g, 10 ~ 2000Hz MIL-STD-810C, Method 514.2, Curve L				
Mechanical Shock	Half-Sine, Peak: 50g, 11ms MIL-STD-202, Method 213B, Condition A				
Package Protection	IP67 (IEC60529)				

Notes

5. The maximum pressure that can be applied without changing the transducer's performance or accuracy.
6. The maximum pressure that can be applied to a transducer without rupture of either the sensing element or transducer.

M7100 Pressure Transducer

Output Type vs. Supply

Output Type (Code)	3	4
Supply Voltage	4.75 ~ 5.25V*	8 ~ 32V
Supply Current	4.0 ~ 10.0mA	
Output Voltage	0.5 ~ 4.5V*	1.0 ~ 5.0V
Reverse Voltage	16V	
Overvoltage Protection	16V	32V

* Output ratiometric to supply voltage

CHART 1: PRESSURE TRANSFER FUNCTIONS

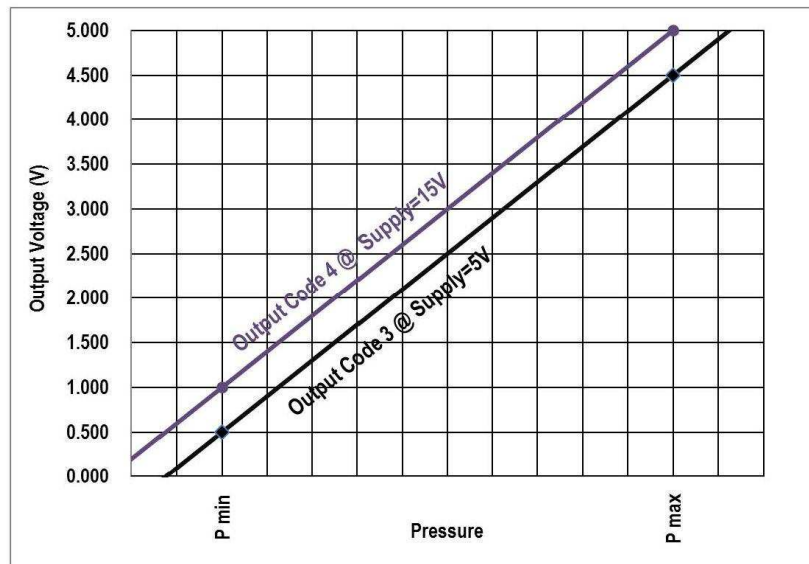

Output Code 3:
Output Voltage = $\frac{80\% \times \text{Supply Voltage}}{P_{\text{max}} - P_{\text{min}}} \times (\text{Pressure applied} - P_{\text{min}}) + 0.500$

Output Code 4:
Output Voltage = $\frac{4}{P_{\text{max}} - P_{\text{min}}} \times (\text{Pressure applied} - P_{\text{min}}) + 1.000$

Agency Approvals

RoHS	RoHS II Compliant
UL 508 Certified	Industrial Control Equipment, CSA22.2 No. 14-10
EMC Performance Criteria	Output Change $\leq \pm 1.5\% \text{ FSO}$
IEC61000-4-2 ESD	8kV Contact / 15kV Air; Discharge Rate > 10s
IEC61000-4-3 EM Field	100V/m, 1kHz 80% Modulation, 80~1000MHz
IEC61000-4-4 Electrical Fast Transient	Level 2, 1KV each line, Capacitance Coupling
IEC61000-4-5 Surge	Level 2, 42Ω Impedance, Figure 11 (L-L 500V, L-E 1KV)
IEC61000-4-6 Conducted RF	Level 2, 3V/130dB, 150KHz~80MHz, 2s Dwell, Clamp Injection
IEC61000-4-9 Pulsed Magnetic Field	Level 3, 100A/m, 10 Second Pulse Interval
IEC55022 Emission	Class B, 30dB @ 30~220MHz, 37dB @ 230~1000MHz

M7100 Pressure Transducer

DIMENSIONS

DIMENSIONS ARE IN INCHES [mm]

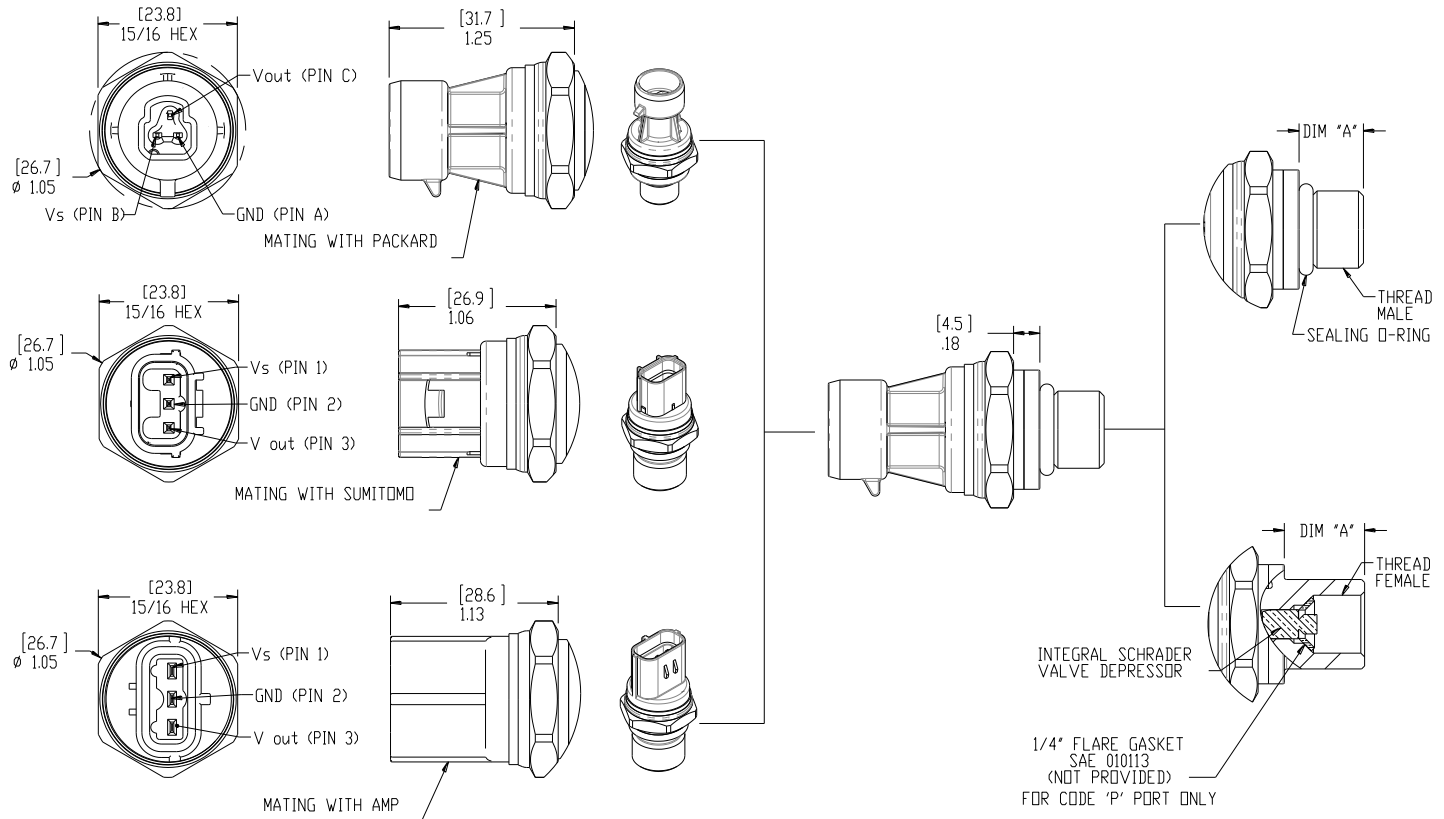

Connector	Vendor	Pin Plating	Mating Connector
Packard Metri-Pack 150 Series	powerandsignal.com	0.003 – 0.005mm Sn	Housing P/N: 12065287 Terminals P/N: 12103881
Sumitomo HV040 Series	sumitomokenki.com	0.003mm Sn over 0.0005 – 0.001mm Cu	Housing P/N: 6189-6907 Terminals P/N: 8100-3067/8
AMP Econoseal-J Mark II 070 Series	te.com	0.0004 mm Au over 0.0013 mm Ni	Housing P/N: 174357 Terminals P/N: 171630

Note: Connector
Do not apply torque to the connector housing of transducer.
To ensure proper environmental sealing and electrical connections when using a mating connector, follow the connector manufacturer's installation guidelines.

Pressure Port Options	Dim A (inches) [mm]	Tightening Torque (Nm)
2 = G1/, BS5380, Male	.43[11.0]	30~35
4 = 7-16-20 UNF, SAE J1926-2, Male, w/ O-Ring	.43[11.0]	18~20
5 = 1/4-18 NPT Male	.56[14.2]	2~3 T.F.F.T.*
6 = 1/8-27 NPT Male	.38[9.7]	2~3 T.F.F.T.*
G = M14x1.5, ISO 6149-2, Male	.43[11.0]	30~35
P = 7/16-20UNF Female w/ Integral Valve Depressor; 1/4 Flare Gasket SAE J513C, Copper	.54[13.7]	15~16
Q = M10x1.0, ISO 6149-2, Male	.37[9.5]	15~16

Others pressure ports available upon request
*T.F.F.T. Turns From Finger Tight

Notes: Installation
Transducers can be installed by either spanner or deep socket. Values provided are for reference; actual torque depends upon mating port material, surface finish, lubrication and sealing mechanism. Transducer calibration and/or zero may shift if it is over-torqued when installing. Check for a zero shift after installing.

M7100 Pressure Transducer

ORDERING INFORMATION

M7138-300PG-200000

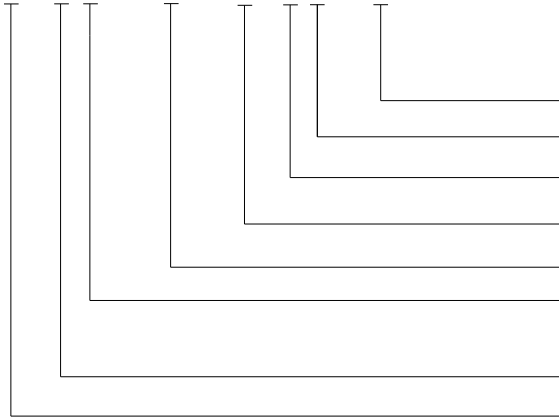

Specials (nnnn = Custom Drawing)
 Port Material (0 = 17-4PH SST)
 Pressure Port (See Pressure Port Options Table)
 Type (G = Gage, N = No Vent Gage)
 Pressure Range (See Pressure Range Table)
 Connection (7 = AMP Connector, 8 = Sumitomo Connector HV040,
 9 = Packard Connector [Supply; PIN B])
 Output (3 = 0.5 - 4.5V, 4 = 1 - 5V)
 Model

NORTH AMERICA

Measurement Specialties
 45738 Northport Loop West
 Fremont, CA 94538
 Tel: 1-800-767-1888
 Fax: 1-510-498-1578
 Sales: pfg.cs.amer@meas-spec.com

EUROPE

Measurement Specialties
 (Europe), Ltd.
 26 Rue des Dames
 78340 Les Clayes-sous-Bois, France
 Tel: +33 (0) 130 79 33 00
 Fax: +33 (0) 134 81 03 59
 Sales: pfg.cs.emea@meas-spec.com

ASIA

Measurement Specialties
 (China), Ltd.
 No. 26 Langshan Road
 Shenzhen High-Tech Park (North)
 Nanshan District, Shenzhen 518057
 China
 Tel: +86 755 3330 5088
 Fax: +86 755 3330 5099
 Sales: pfg.cs.asia@meas-spec.com

The information in this sheet has been carefully reviewed and is believed to be accurate; however, no responsibility is assumed for inaccuracies. Furthermore, this information does not convey to the purchaser of such devices any license under the patent rights to the manufacturer. Measurement Specialties, Inc. reserves the right to make changes without further notice to any product herein. Measurement Specialties, Inc. makes no warranty, representation or guarantee regarding the suitability of its product for any particular purpose, nor does Measurement Specialties, Inc. assume any liability arising out of the application or use of any product or circuit and specifically disclaims any and all liability, including without limitation consequential or incidental damages. Typical parameters can and do vary in different applications. All operating parameters must be validated for each customer application by customer's technical experts. Measurement Specialties, Inc. does not convey any license under its patent rights nor the rights of others.