

# MS4525DO



- PCB Mounted Digital Output Transducer
- Combination Temperature and Pressure
- I<sup>2</sup>C or SPI Protocol
- Differential, Gage, Absolute & Compound, Vacuum
- Temperature Compensated
- 3.3 or 5.0 Vdc Supply Voltage
- Low Power Option Available (standby < 1uA)

## DESCRIPTION

The MS4525DO is a small, ceramic based, PCB mounted pressure transducer from Measurement Specialties. The transducer is built using Measurement Specialties' proprietary UltraStable™ process and the latest CMOS sensor conditioning circuitry to create a low cost, high performance Digital Output Pressure (14bit) and Temperature (11bit) transducer designed to meet the strictest requirements from OEM customers.

The MS4525DO is fully calibrated and temperature compensated with a total error band (TEB) of less than 1.0% over the compensated pressure range. The sensor operates from single supply of either 3.3 or 5.0Vdc and requires a single external component for proper operation.

The rugged ceramic transducer is available in side port, top port, and manifold mount and can measure absolute, gauge, differential, vacuum or compound pressure from 1 to 150psi. The 1/8" barbed pressure ports mate securely with 3/32" ID tubing.

## FEATURES

- PSI Pressure Ranges
- PCB Mountable
- Digital Output
- Barbed Pressure Ports

## APPLICATIONS

- Factory Automation, Vacuum Switch
- Altitude and Airspeed Measurements
- Medical Instruments
- Leak Detection

## STANDARD RANGE (PSI)

Pressure	Absolute	Gauge	Differential	Compound	Vacuum
1		DS, SS, TP, MM	DS, SS,TP, MM		
2		DS, SS, TP, MM	DS, SS,TP, MM		
5		DS, SS, TP, MM	DS, SS,TP ,MM		
15	SS, TP	DS, SS, TP, MM	DS, MM	SS, TP	SS, TP, DS
30	SS, TP	DS, SS, TP, MM	DS, MM	SS, TP	
50	SS, TP	DS, SS, TP, MM	DS, MM	SS, TP	
100	SS, TP	DS, SS, TP, MM	DS, MM	SS, TP	
150	SS, TP	DS, SS, TP, MM	DS, MM	SS, TP	

See Package Configurations: DS= Dual Side Port, SS= Single Side Port, TP= Top Port, MM= Manifold Mount  
 Only I<sup>2</sup>C Protocol is Available on "L" type Pin Styles; Reference Ordering Information for Details  
 Pin Style "L" is only available SS and MM port types.

# MS4525DO

## BLOCK DIAGRAM

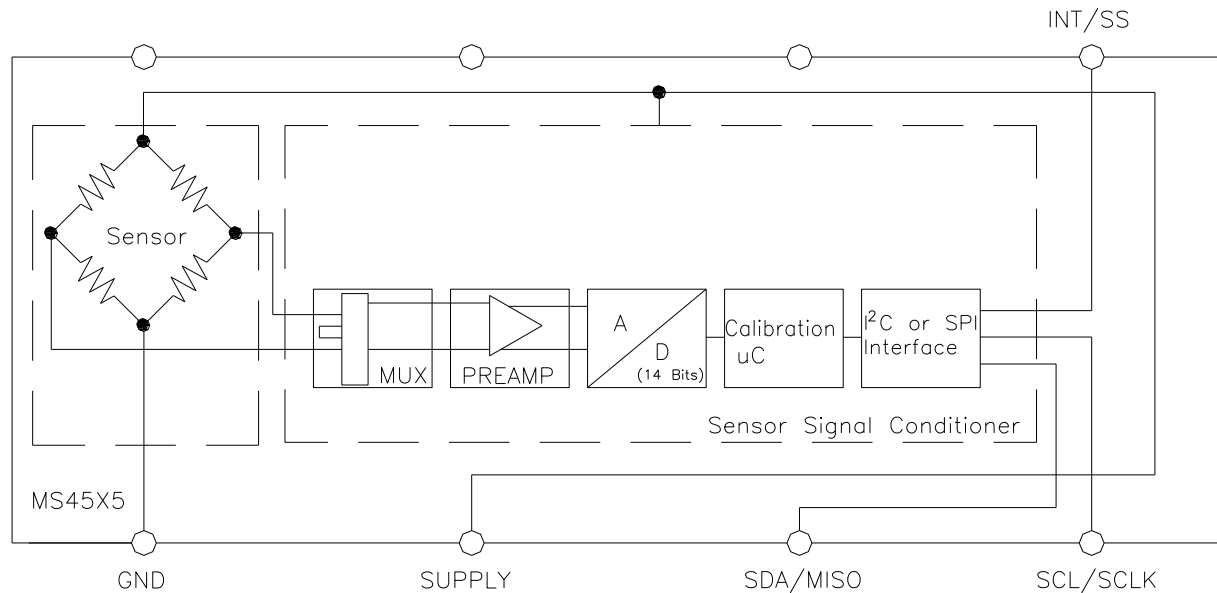

## ABSOLUTE MAXIMUM RATINGS

Parameter	Conditions	Min	Max	Unit	Notes
Supply Voltage	T <sub>A</sub> = 25 °C	2.7	5.5	V	
Output Current	T <sub>A</sub> = 25 °C		3	mA	
Storage Temperature		-40	+125	°C	
Humidity	T <sub>A</sub> = 25 °C		95	%RH	Non Condensing
Overpressure	T <sub>A</sub> = 25 °C, both Ports	Not to Exceed 300		psi	
Burst Pressure	T <sub>A</sub> = 25 °C, Port 1			psi	See Table 1
ESD	HBM	-4	+4	kV	EN 61000-4-2
Solder Temperature		250°C, 5 sec max.			

**TABLE 1- BURST PRESSURE BY RANGE AND PACKAGE STYLE**

Range	DS	SS, TP, MM	Unit
001	20	20	psi
002	20	20	psi
005	15	20	psi
015	45	90	psi
030	90	200	psi
050	150	300	psi
100	300	300	psi
150	300	300	psi

# MS4525DO

## ENVIRONMENTAL SPECIFICATIONS

Parameter	Conditions
Mechanical Shock	Mil Spec 202F, Method 213B, Condition C, 3 Drops
Mechanical Vibration	Mil Spec 202F, Method 214A, Condition 1E, 1Hr Each Axis
Thermal Shock	100 Cycles over Storage Temperature, 30 minute dwell
Life	1 Million FS Cycles
MTTF	>10Yrs, 70 °C, 10 Million Pressure Cycles, 120%FS Pressure

## PERFORMANCE SPECIFICATIONS

Supply Voltage<sup>1</sup>: 5.0V or 3.3 Vdc

Reference Temperature: 25°C (unless otherwise specified)

PARAMETERS	MIN	TYP	MAX	UNITS	NOTES
Pressure Accuracy	-0.25		0.25	%Span	2
Total Error Band (TEB)	-1.0		1.0	%Span	3,7
Temperature Accuracy		1.5		°C	4
Supply Current		3		mA	7
Compensated Temperature	-10		85	°C	5
Operating Temperature	-25		+105	°C	
Output Pressure Resolution			14	bits	
Output Temperature Resolution	8		11	bits	
Update Time		0.5		mS	6
Start Time to Data Ready			8.4	mS	6
Weight		3		grams	
Media	Non-Corrosive Dry Gases Compatible with Ceramic, Silicon, Pyrex, PPS, RTV, Gold, Aluminum and Epoxy. See "Wetted Material by Port Designation" chart below.				

### Notes

1. Proper operation requires an external capacitor placed as shown in Connection Diagram. Output is not ratiometric to supply voltage.
2. The maximum deviation from a best fit straight line (BFSL) fitted to the output measured over the pressure range at 25C. Includes all errors due to pressure non linearity, hysteresis, and non repeatability.
3. Total pressure error band includes all accuracy errors, thermal errors over the compensated temperature range and span and offset calibration tolerances. For ideal sensor output with respect to input pressure and temperature, reference Transfer Function charts below. TEB values are valid only at the calibrated supply voltage.
4. The deviation from a best fit straight line (BFSL) fitted to the output measured over the compensated temperature range.
5. For errors beyond the compensated temperature range, see Extended Temperature Multiplier chart below.
6. Start time to data ready is the time to get valid data after POR (power on reset). The time to get subsequent valid data is then specified by the update time specification.
7. This product can be configured for custom OEM requirements, contact factory for lower power consumption or higher accuracy.

# MS4525DO

## CONNECTION DIAGRAM

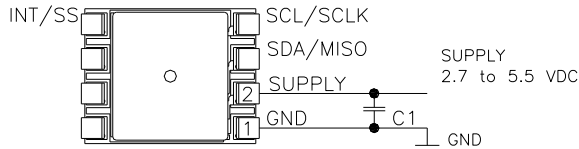

### Notes

- Place 100nF capacitor between Supply and GND to within 2 cm of sensor.

## PRESSURE AND TEMPERATURE TRANSFER FUNCTION

### Gage, Differential and Compound Pressure Types

Pressure Transfer Functions

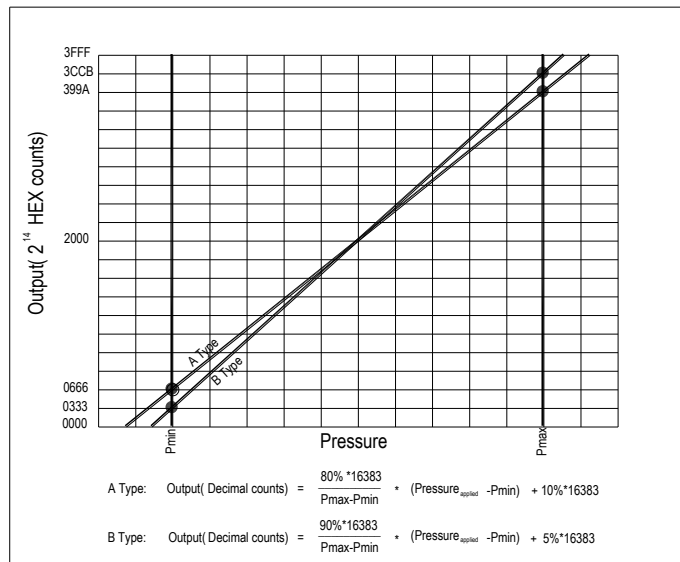

Temperature Transfer Functions

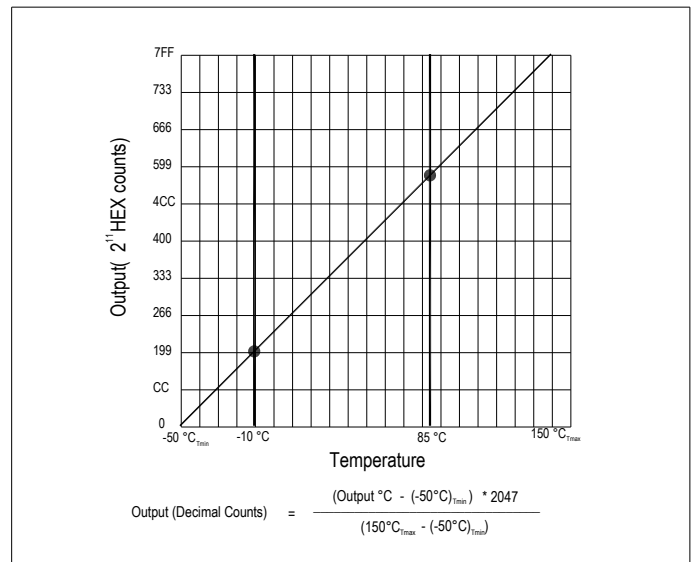

Sensor Output at Significant Percentages

% of Counts	Output Type A (PSI)	Output Type B (PSI)	Digital Counts (decimal)	Digital Counts (hex)
0	$P_{\text{min}} - (P_{\text{max}} - P_{\text{min}}) \cdot 10/80$	$P_{\text{min}} - (P_{\text{max}} - P_{\text{min}}) \cdot 5/90$	0	0 X 0000
5		$P_{\text{min}}$	819	0 X 0333
10	$P_{\text{min}}$		1638	0 X 0666
50			8192	0 X 2000
90	$P_{\text{max}}$		14746	0 X 399A
95		$P_{\text{max}}$	15563	0 X 3CCB
100	$P_{\text{max}} + (P_{\text{max}} - P_{\text{min}}) \cdot 10/80$	$P_{\text{max}} + (P_{\text{max}} - P_{\text{min}}) \cdot 5/90$	16383	0 X 3FFF

Temperature Output vs Counts

Output °C	Digital Counts (decimal)	Digital Counts (hex)
-50	0	0 X 0000
0	511	0 X 01FF
10	614	0 X 0266
25	767	0 X 02FF
50	1023	0 X 03FF
85	1381	0 X 0565
150	2047	0 X 07FF

# MS4525DO

## Vacuum Pressure Type

Vacuum Series Pressure Transfer Functions

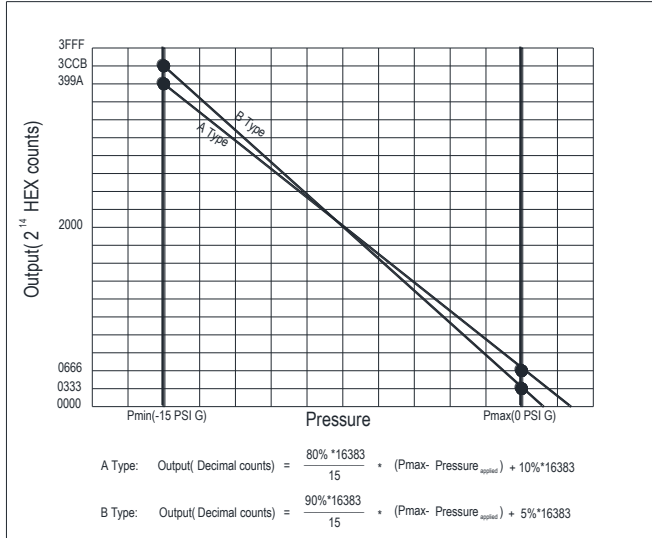

Temperature Transfer Functions

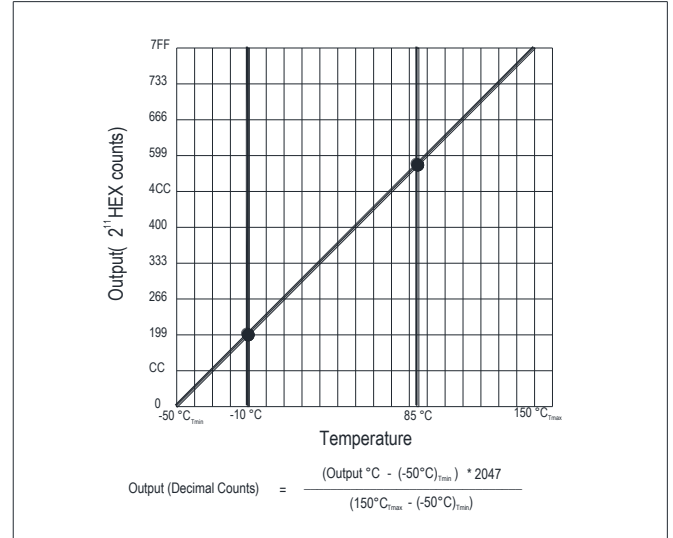

Sensor Output at Significant Percentages

% of Counts	Output Type A (PSIG)	Output Type B (PSIG)	Digital Counts (decimal)	Digital Counts (hex)
0	1.6875	0.833	0	0 X 0000
5		0	819	0 X 0333
10	0		1638	0 X 0666
50			8192	0 X 2000
90	-15		14746	0 X 399A
95	-	-15	15563	0 X 3CCB
100	-	-	16383	0 X 3FFF

Temperature Output vs Counts

Output °C	Digital Counts (decimal)	Digital Counts (hex)
-50	0	0 X 0000
0	511	0 X 01FF
10	614	0 X 0266
25	767	0 X 02FF
50	1023	0 X 03FF
85	1381	0 X 0565
150	2047	0 X 07FF

# MS4525DO

## EXTENDED TEMPERATURE MULTIPLIER CHART

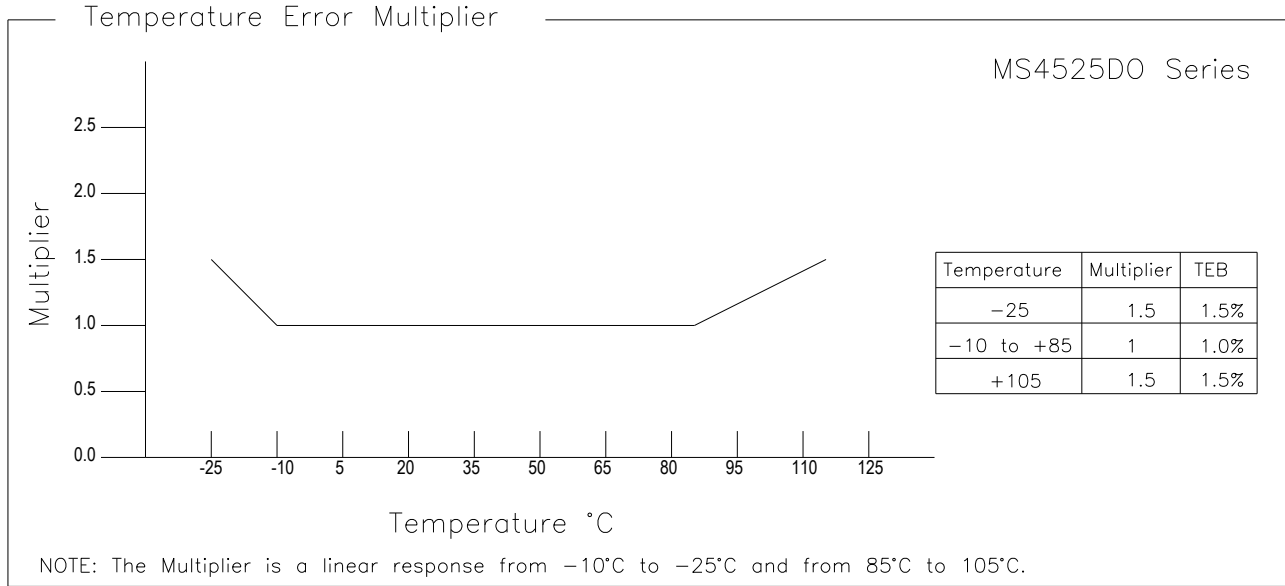

## PACKAGE, PINOUT & PRESSURE TYPE CONFIGURATION

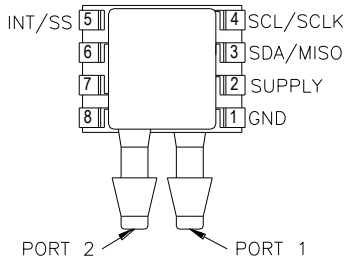

MS4525DO-DSvoixxyP

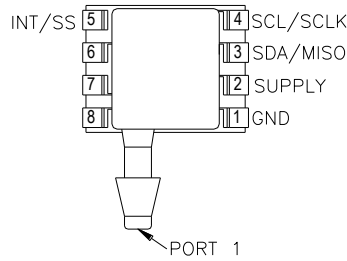

MS4525DO-SSvoixxyP

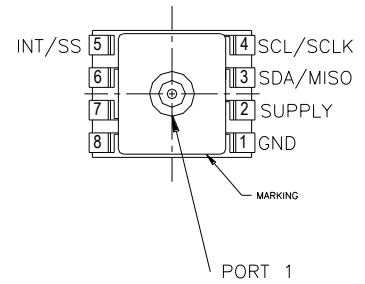

MS4525DO-TPvoixxyP

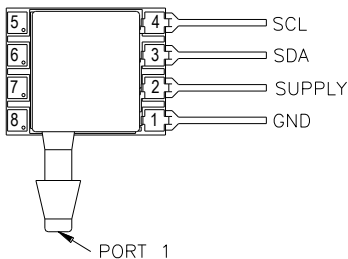

MS4525DO-SSvoixxyL

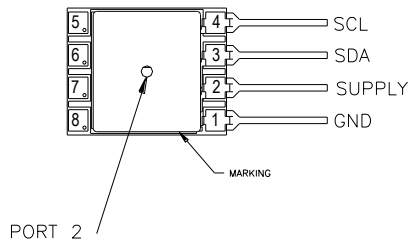

MS4525DO-MMvoixxyL

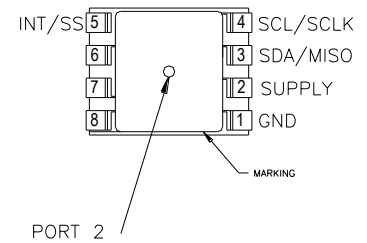

MS4525DO-MMvoixxyP

# MS4525DO

Pin Name	Pin	Function
GND	1	Ground
SUPPLY	2	Positive Supply Voltage
SDA MISO	3	I2C Data SPI Data
SCL SCLK	4	I2C Clock SPI Clock
INT SS	5	I2C Interrupt SPI Chip Select
	6-8	No Connection

INT is not available for Pin Style "L" models

Pressure Type	Pmin	Pmax	Description
Absolute	0psiA	+Prange	Output is proportional to the difference between 0psiA (Pmin) and pressure applied to Port 1.
Differential/ Bidirectional	-Prange	+Prange	Output is proportional to the difference between Port 1 and Port 2. Output swings positive when Port 1 > Port 2. Output is 50% of total counts when Port 1=Port 2.
Gauge	0psiG	+Prange	Output is proportional to the difference between 0psiG (Pmin) and Port 1. Output swings positive when Port 1 > Port 2.
Vacuum	-15psiG	+0psiG	Output is inversely proportional to the difference between -15psiG pressure (Pmin) and pressure applied to Port 1.
Compound	-15psiG	+Prange	Output is proportional to the difference between -15psiG pressure (Pmin) and pressure applied to Port 1.

Prange is equal to the maximum full scale pressure specified in the ordering information.

## WETTED MATERIAL BY PORT DESIGNATION

Style	Port	Material							
		PPS	Ceramic	Silicon	Pyrex	RTV	Gold	Aluminum	Epoxy
DS, MM	Port 1	X	X	X	X	X			X
	Port 2	X	X	X	X	X	X	X	X
SS, TP	Port 1	X	X	X	X	X	X	X	X

"X" Indicates Wetted Material

# MS4525DO

## DIMENSIONS

DIMENSIONS ARE IN INCHES [mm]

Model MS4525DO-DSvoixxyP

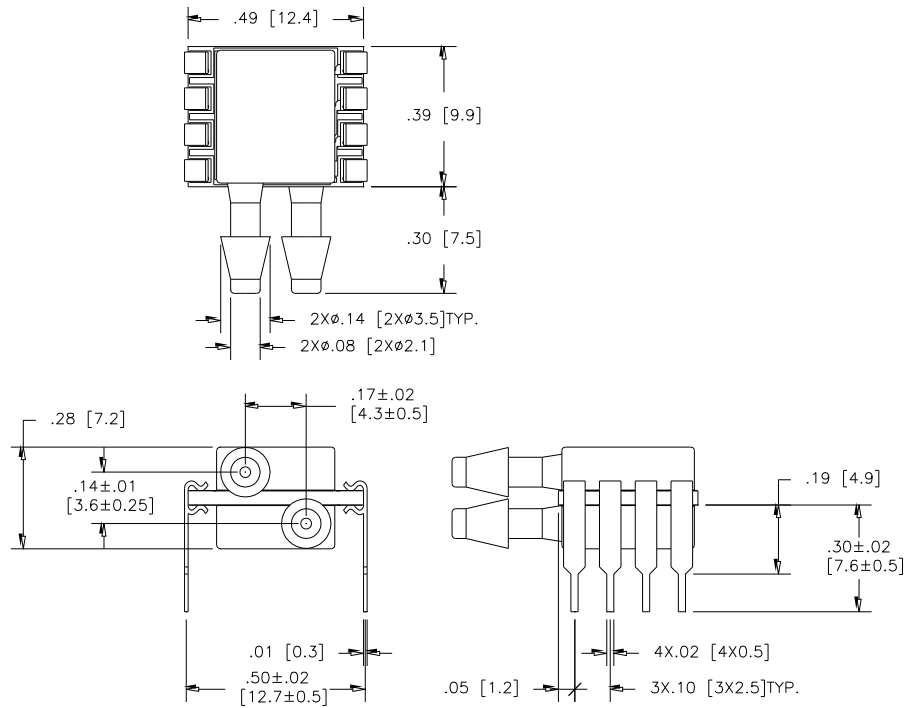

Model MS4525DO-DSvoixxyS

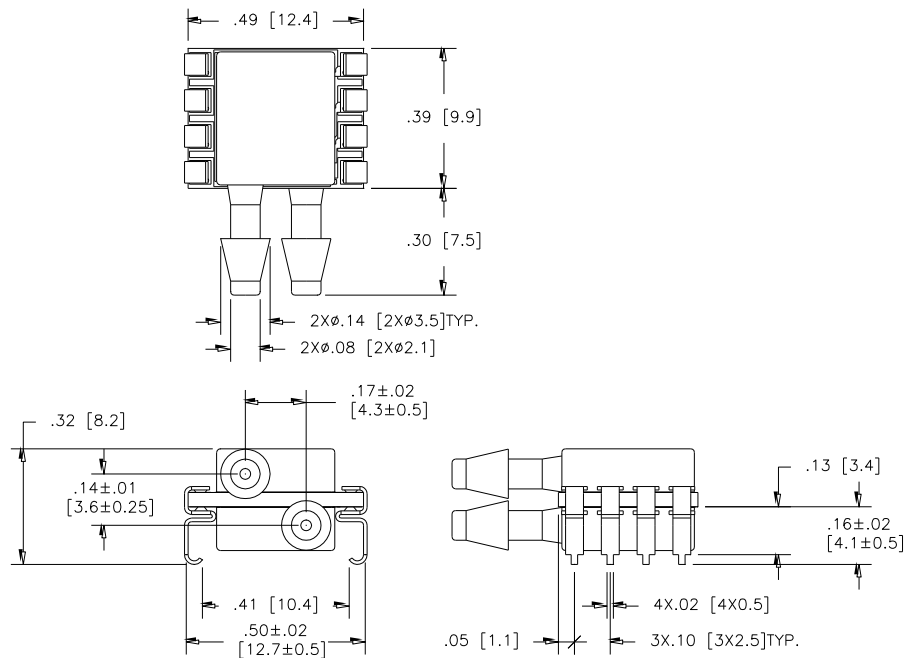



# MS4525DO

DIMENSIONS ARE IN INCHES [mm]

Model MS4525DO-SSvoixxyP

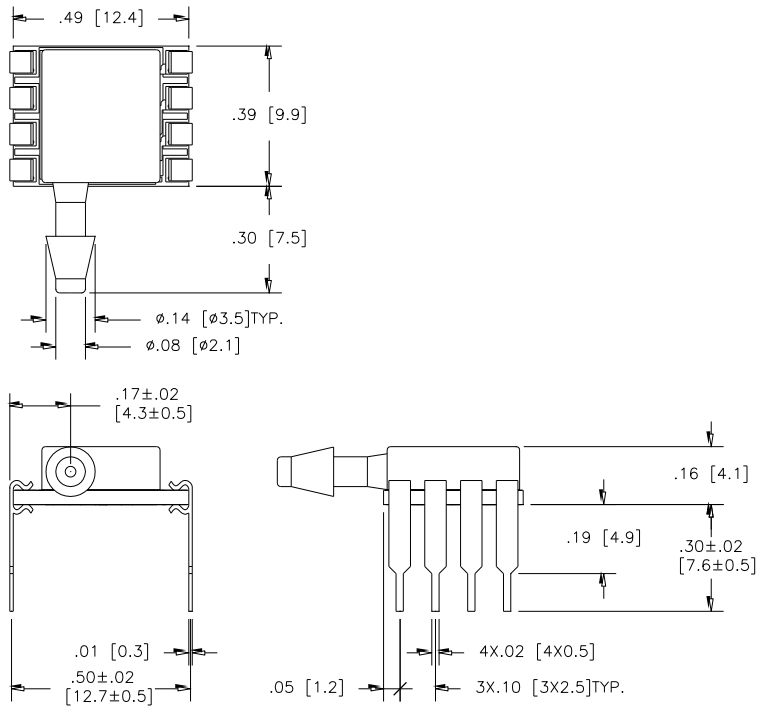

Model MS4525DO-SSvoixxyS

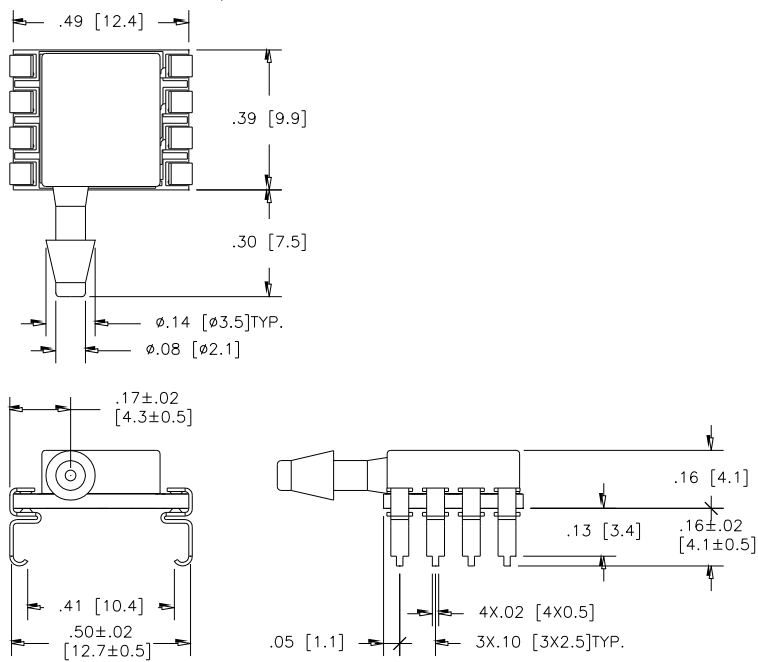

# MS4525DO

DIMENSIONS ARE IN INCHES [mm]

Model MS4525DO-TPvoixxyP

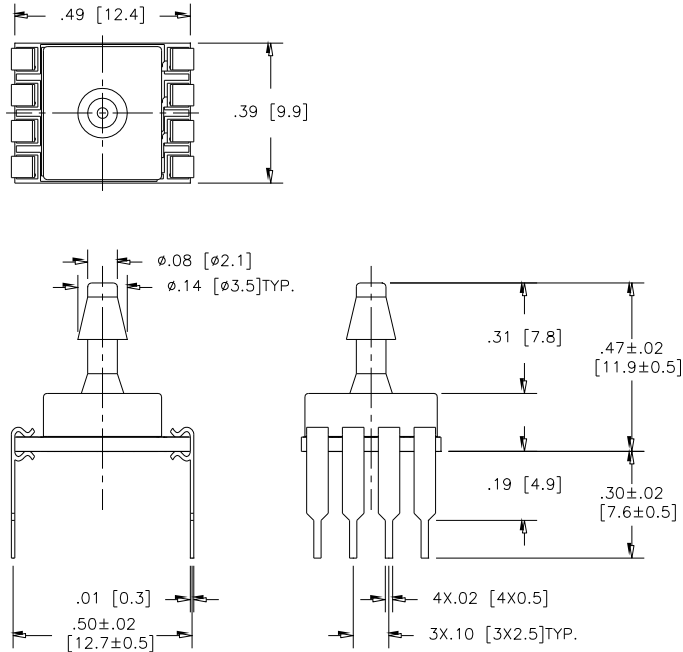

Model MS4525DO-TPvoixxyS

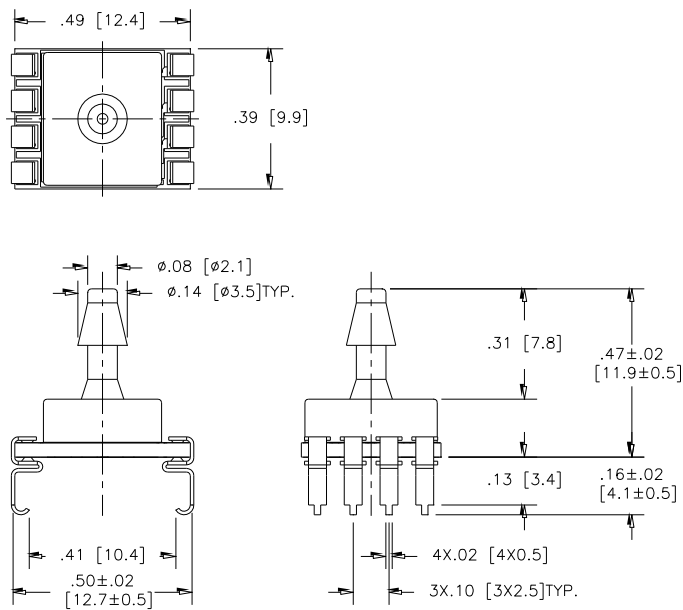

# MS4525DO

DIMENSIONS ARE IN INCHES [mm]

Model MS4525DO-SSvoixxyL

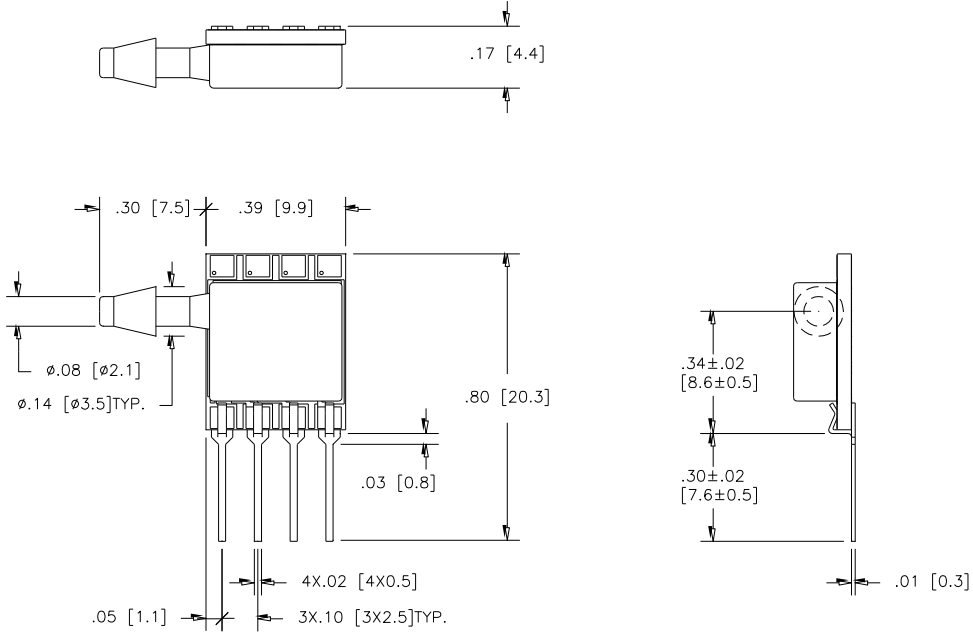

Model MS4525DO-MMvoixxyL

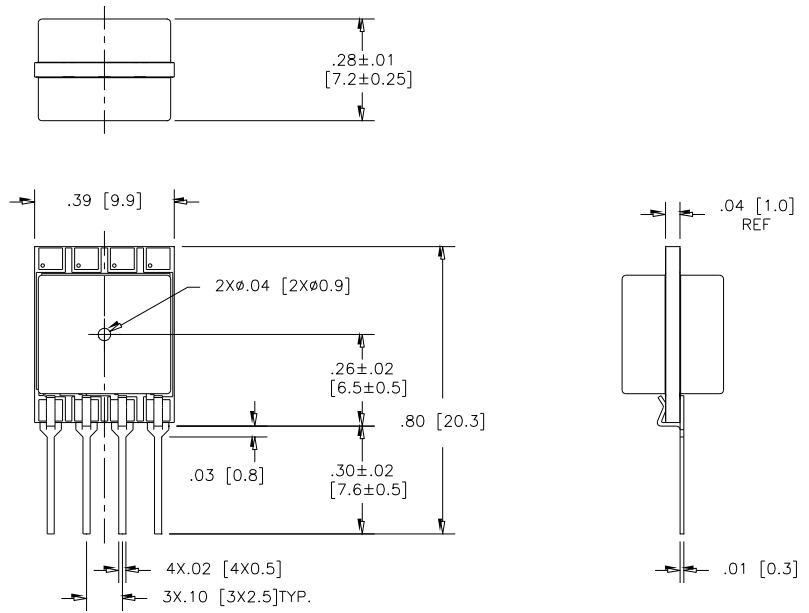

# MS4525DO

DIMENSIONS ARE IN INCHES [mm]

Model MS4525DO-MMvoixxyP

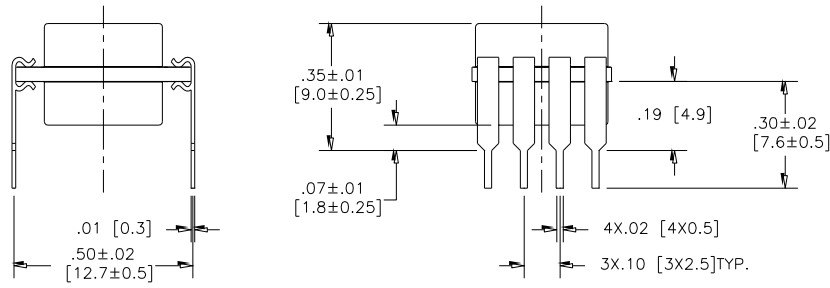
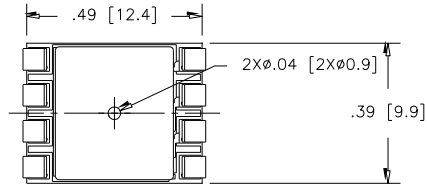

Model MS4525DO-MMvoixxyS

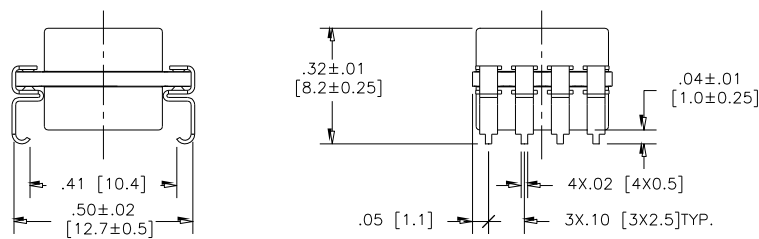
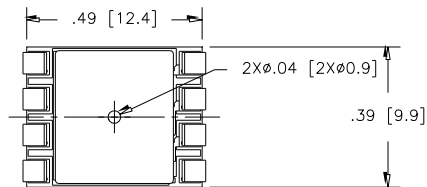

# MS4525DO

---

## APPLICATION NOTES

---

Measurement Specialties offers a comprehensive selection of product support documentation. The items below can be found on the Literature tab under **PRESSURE SENSOR - MS45XX SERIES**.

### *MS45xx Series Application Note*

- Bypass Capacitor Selection
- Pressure Hose Recommendations
- PCB Layout Recommendations

### *Interfacing to MEAS Digital Pressure Modules*

- I<sup>2</sup>C or SPI Protocol Description
- Data Fetch, Measurement Request Commands
- Timing Diagrams

### *Configuration, POR and Power Consumption*

- Standard and Low Power Configuration
- Power On Reset (POR)
- Current Consumption by Sampling Frequency

---

## AVAILABLE OPTIONS

---

### **Gel Coat (-F Option)**

The MS45x5 is designed for non ionic and clean dry air applications. Select this option for added protection in high humidity or slightly corrosive environments with the application of a silicone gel elastomer to sensor and ASIC. For questions concerning media compatibility, contact the factory.

### **Low Power (-L Option)**

Select this option for battery powered or handheld device applications. In this configuration, the sensor and calibration microcontroller are powered down, drawing a current of  $\sim 0.6\mu\text{A}$  ( $V_s=5.0\text{ Vdc}$ ). When the master sends a **Read MR** (measurement request) command (I<sup>2</sup>C or SPI); the sensor is “awaken” and begins the measurement cycle; data is then placed onto the output registers. The sensor and calibration microcontroller are powered down again, awaiting the **Read DF** (data fetch) command from the master.

# MS4525DO

## ORDERING INFORMATION

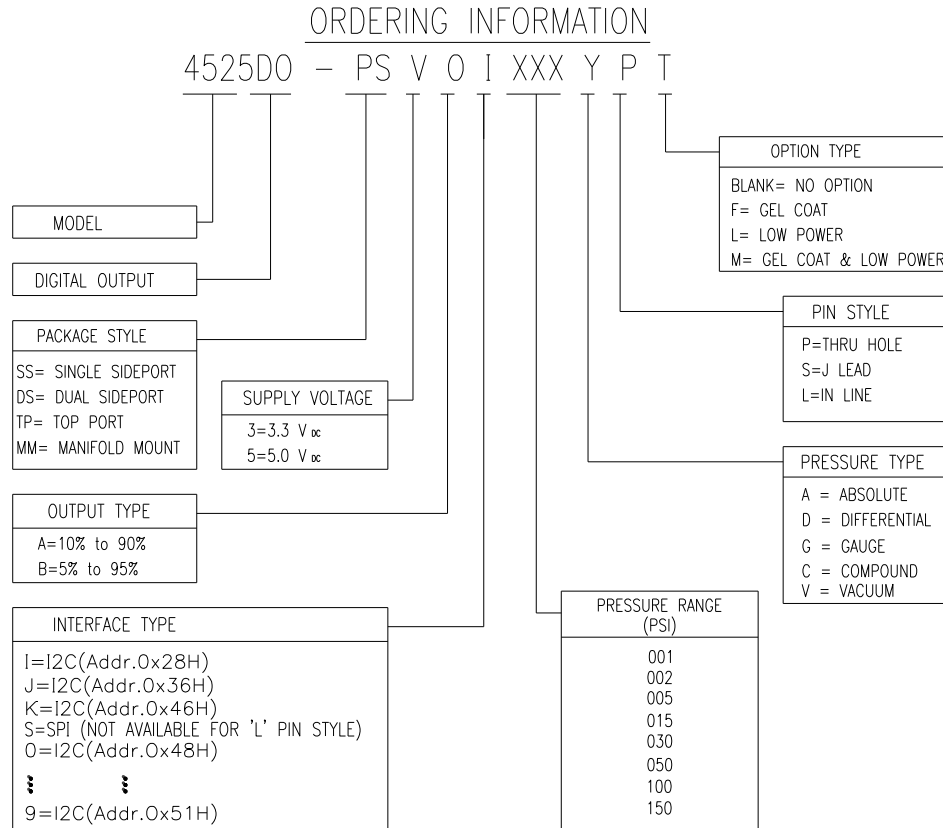

### NORTH AMERICA

Measurement Specialties  
 45738 Northport Loop West  
 Fremont, CA 94538  
 Tel: 1-800-767-1888  
 Fax: 1-510-498-1578  
 Sales: [pfg.cs.amer@meas-spec.com](mailto:pfg.cs.amer@meas-spec.com)

### EUROPE

Measurement Specialties  
 (Europe), Ltd.  
 26 Rue des Dames  
 78340 Les Clayes-sous-Bois, France  
 Tel: +33 (0) 130 79 33 00  
 Fax: +33 (0) 134 81 03 59  
 Sales: [pfg.cs.emea@meas-spec.com](mailto:pfg.cs.emea@meas-spec.com)

### ASIA

Measurement Specialties  
 (China), Ltd.  
 No. 26 Langshan Road  
 Shenzhen High-Tech Park (North)  
 Nanshan District, Shenzhen 518057  
 China  
 Tel: +86 755 3330 5088  
 Fax: +86 755 3330 5099  
 Sales: [pfg.cs.asia@meas-spec.com](mailto:pfg.cs.asia@meas-spec.com)

The information in this sheet has been carefully reviewed and is believed to be accurate; however, no responsibility is assumed for inaccuracies. Furthermore, this information does not convey to the purchaser of such devices any license under the patent rights to the manufacturer. Measurement Specialties, Inc. reserves the right to make changes without further notice to any product herein. Measurement Specialties, Inc. makes no warranty, representation or guarantee regarding the suitability of its product for any particular purpose, nor does Measurement Specialties, Inc. assume any liability arising out of the application or use of any product or circuit and specifically disclaims any and all liability, including without limitation consequential or incidental damages. Typical parameters can and do vary in different applications. All operating parameters must be validated for each customer application by customer's technical experts. Measurement Specialties, Inc. does not convey any license under its patent rights nor the rights of others.