

89BSD Digital Output

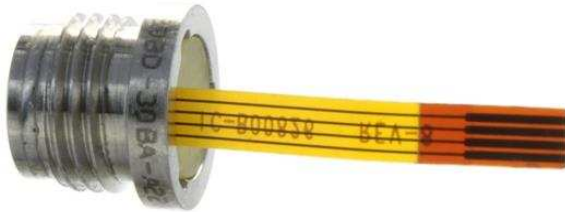

- Stainless Steel with O-Ring Seal
- Pressure/Temperature Read-Out
- Digital Output (24-bit $\Delta\Sigma$ ADC)
- ASIC Calibrated
- Absolute, Sealed Gage
- 9mm Diameter



DESCRIPTION

The 89BSD is a 9mm diameter small profile, media compatible, piezoresistive silicon pressure sensor packaged in a 316L stainless steel housing. This low power 24-bit $\Delta\Sigma$ ADC digital output pressure sensor supports an I²C interface protocol and is designed for threaded o-ring mounting. A custom ASIC is used for temperature compensation and offset correction. The sensing package utilizes silicone oil to transfer pressure from the 316L stainless steel diaphragm to the sensing element. A flex cable allows the 89BSD to connect to a smaller connection terminal where size is of primary concern.

The 89BSD is designed for high performance, low pressure applications.

For a similar sensor with a plastic threaded fitting, refer to the LM pressure transducer.

FEATURES

- Threaded/Weldable
- I²C Interface
- Low Power: <1 μ A
- Standby Power: <0.15 μ A
- Supply Voltage: 1.8 to 3.6Vdc

APPLICATIONS

- Level Controls
- Tank Level Measurement
- Corrosive Fluids and Gas Measurement Systems
- Sealed Systems
- Manifold Pressure Measurement
- Barometric Pressure Measurement
- Dive Computers

STANDARD RANGES

Range	BarA	BarS
0 to 006	•	•
0 to 012	•	•
0 to 018	•	•
0 to 028	•	•
0 to 030	•	•

Intermediate pressure ranges available, contact factory

89BSD Digital Output

PERFORMANCE SPECIFICATIONS

Supply Voltage: 3Vdc

Ambient Temperature: 25°C (unless otherwise specified)

PARAMETERS	MIN	TYP	MAX	UNITS	NOTES
ADC			24	bit	
Input Voltage Range	1.8		3.6	V	2
Supply Current		See Table 1		mA	
Pressure Resolution		See Table 3		%Span	3
Pressure Accuracy		±0.3		%Span	
Total Error Band		See Graph 1		%Span	
Conversion Time		See Table 2		ms	3
Long Term Stability		±0.2		%Span/yr	
Compensated Temperature	-20		+85	°C	
Temperature Resolution		See Table 3		°C	
Temperature Accuracy	-2		+2	°C	
Operating Temperature	-40		+85	°C	
Storage Temperature	-40		+125	°C	
Pressure Overload			2X	Rated	4
Pressure Burst			3X	Rated	5
Interface Type		I ² C			6
Media, Pressure Port	Liquids and gases compatible with 316/316L Stainless Steel				

Notes

1. Coefficients must be read by microcontroller software and are to be used in a mathematical calculation for converting D1 and D2 into compensated pressure and temperature values. For calculation methods and coefficients, see application note APP-01006.
2. Output is not ratiometric to supply voltage.
3. Oversampling ratio: 256 / 512 / 1024 / 2048 / 4096. See Table 2.
4. 2X or 400psi, whichever is less. The maximum pressure that can be applied without changing the transducer's performance or accuracy.
5. 3X or 600psi, whichever is less. The maximum pressure that can be applied to a transducer without rupture of either the sensing element or transducer.
6. Output protocol is I²C only. CSB is tied to GND, setting I²C address: 11101111 EF

89BSD Digital Output

Table 1: Supply Current Characteristics

PARAMETERS	Symbol	Conditions	MIN	TYP	MAX	UNITS
Supply Current (1 Sample per second)	I_{DD}	OSR 4096		12.5		
		2048		6.3		
		1024		3.2		μA
		512		1.7		
		256		0.9		
Peak Supply Current		During Conversion		1.4		mA
Standby Supply Current		@ 25°C		0.02	0.14	μA

Table 2: Analog Digital Converter (ADC)

PARAMETERS	Symbol	Conditions	MIN	TYP	MAX	UNITS
Conversion Time	t_c	OSR 4096	7.40	8.22	9.04	
		2048	3.72	4.13	4.54	
		1024	1.88	2.08	2.28	ms
		512	0.95	1.06	1.17	
		256	0.48	0.54	0.60	

Table 3: Typical Resolution

OSR	Typical Pressure Resolution (%Span)	Typical Temperature Resolution (°C)
4096	0.0015	0.002
2048	0.0025	0.003
1024	0.003	0.005
512	0.005	0.008
256	0.008	0.012

Graph 1:

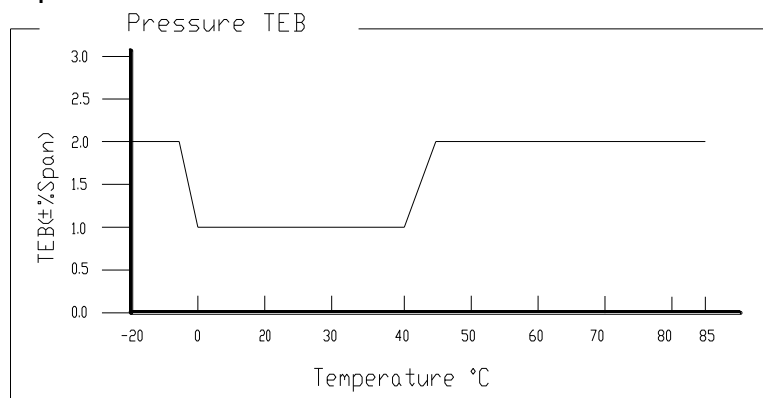

89BSD Digital Output

DIMENSIONS

DIMENSIONS ARE IN INCHES [MM]

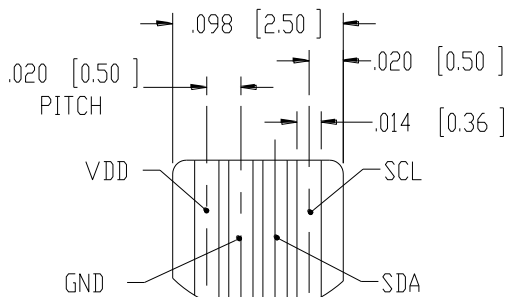
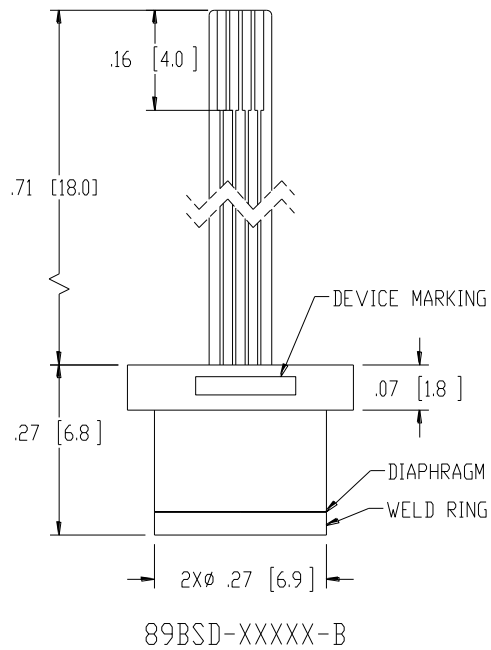
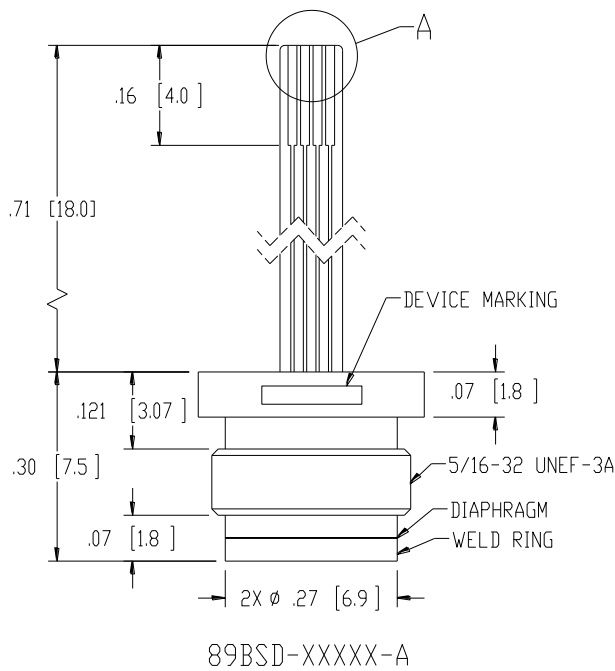
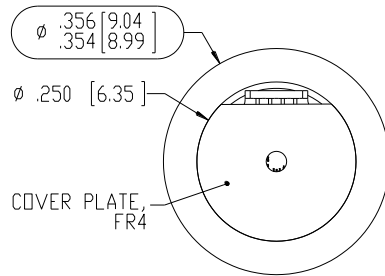
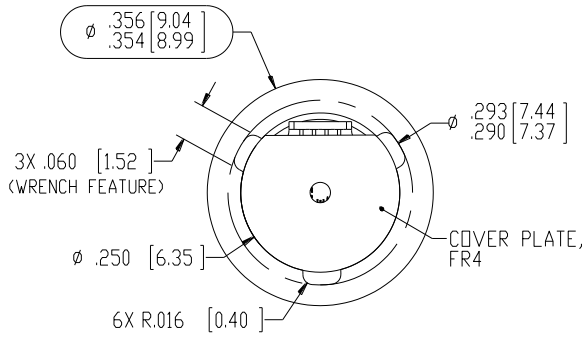

DETAIL A
SCALE 8 : 1
RECOMMEND MOLEX CONNECTOR 52746-0471
(OR EQUIVALENT) TO MATE WITH FPC CABLE

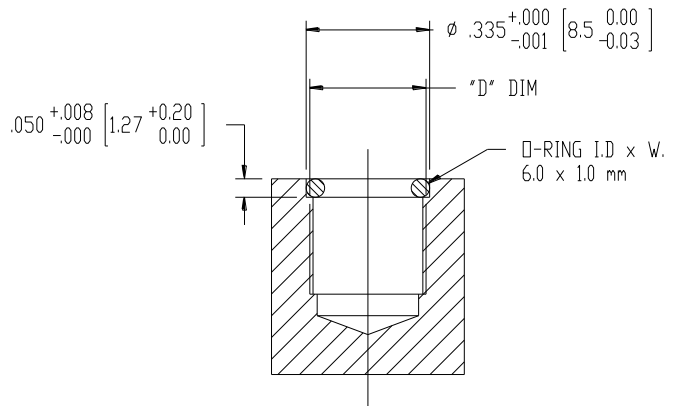

D-RING SEAL MOUNTING
RECOMMENDATIONS
FOR FITTING TYPES A & B

89BSD Digital Output

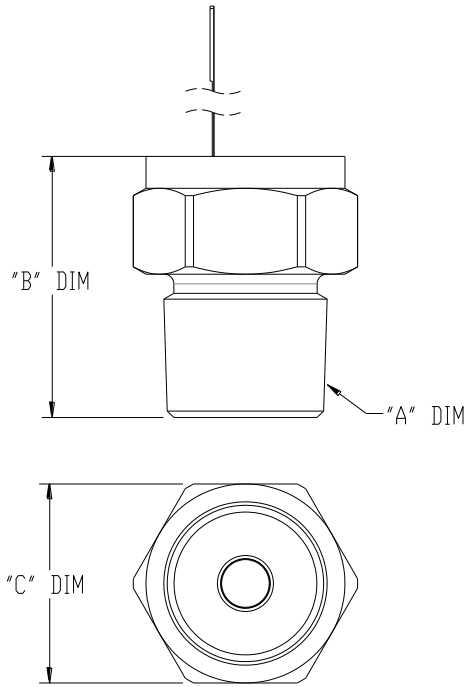

FITTING TYPE	"A" DIM	"B" DIM	"C" DIM	"D" DIM
4	1/4-18 NPT	.82 [20.8]	5/8 [15.9] HEX	N/A
5	1/4-19 BSP	.82 [20.8]	3/4 [19.0] HEX	
8	1/8-27 NPT	.71 [18.0]	5/8 [15.9] HEX	
A	NO FITTING, THREADED CAPSULE, 5/16-32 UNEF-3A			5/16-32 UNEF-3B ∇ .25
B	NO FITTING, NO THREAD CAPSULE			ϕ .28 ∇ .25
NOTE : FITTING TYPE '-4' ASSEMBLY SHOWN FAR LEFT ALL DIMS ARE FOR REFERENCE ONLY				

89BSD-XXXX-4, -5, -8

BLOCK DIAGRAM

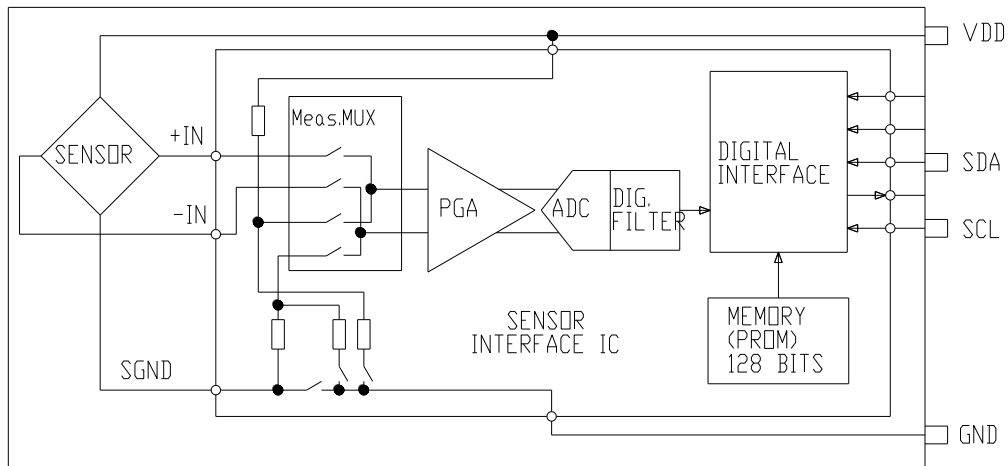

89BSD Digital Output

RECOMMENDED WRENCH DIMENSIONS

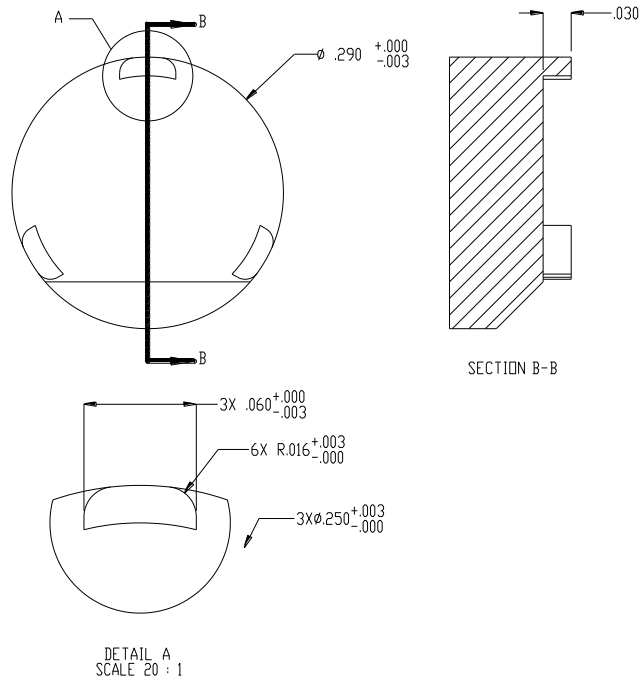

ORDERING INFORMATION

89BSD - 012BA - A

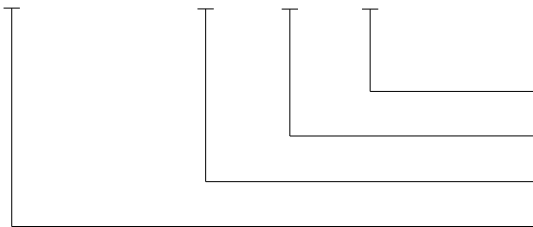

Fitting Type (See Table 4)
Type (A = Absolute, S = Sealed Gage)
Pressure Range
Model

NORTH AMERICA

Measurement Specialties
45738 Northport Loop West
Fremont, CA 94538
Tel: 1-800-767-1888
Fax: 1-510-498-1578
Sales: pfg.cs.amer@meas-spec.com

EUROPE

Measurement Specialties
(Europe), Ltd.
26 Rue des Dames
78340 Les Clayes-sous-Bois, France
Tel: +33 (0) 130 79 33 00
Fax: +33 (0) 134 81 03 59
Sales: pfg.cs.emea@meas-spec.com

ASIA

Measurement Specialties
(China), Ltd.
No. 26 Langshan Road
Shenzhen High-Tech Park (North)
Nanshan District, Shenzhen 518057
China
Tel: +86 755 3330 5088
Fax: +86 755 3330 5099
Sales: pfg.cs.asia@meas-spec.com

The information in this sheet has been carefully reviewed and is believed to be accurate; however, no responsibility is assumed for inaccuracies. Furthermore, this information does not convey to the purchaser of such devices any license under the patent rights to the manufacturer. Measurement Specialties, Inc. reserves the right to make changes without further notice to any product herein. Measurement Specialties, Inc. makes no warranty, representation or guarantee regarding the suitability of its product for any particular purpose, nor does Measurement Specialties, Inc. assume any liability arising out of the application or use of any product or circuit and specifically disclaims any and all liability, including without limitation consequential or incidental damages. Typical parameters can and do vary in different applications. All operating parameters must be validated for each customer application by customer's technical experts. Measurement Specialties, Inc. does not convey any license under its patent rights nor the rights of others.