

TPT300V IR Pyrometer



✓RoHS

CE

- Contactless Temperature Measurement
- High Accuracy
- Wide Temperature Range
- Digital and Analogue Interface
- Industrial Usage (IP65)

DESCRIPTION

TPT 300 is a contactless temperature measuring system - called pyrometer - based on the detection of infrared radiation.

TPT 300 is equipped with a lens and an infrared sensor (Thermopile) in front. It has to be pointed at the target object.

The basic working principle is:

- Detection of infrared radiation with a Thermopile sensor
- Further analogue signal processing
- Calculation of the objects temperature using a microcontroller
- Providing the objects temperature at digital or analogue output

The main fields of applications are temperature measuring in industrial applications i.e. at moving or inaccessible parts.

FEATURES

- 0°C – 300°C Measurement Range
- 9V – 24V Supply Voltage Range
- RS232 Interface & Analogue Voltage Output
- IP65 protected

APPLICATIONS

- Contactless Temperature Measurement
- Industrial Process Control

TPT300V IR Pyrometer

ABSOLUTE MAXIMUM RATINGS

Absolute maximum ratings are limiting values of permitted operation and should never be exceeded under the worst possible conditions either initially or consequently. If exceeded by even the smallest amount, instantaneous catastrophic failure can occur. And even if the device continues to operate satisfactorily, its life may be considerably shortened.

Parameter	Symbol	Conditions	Min	Typ	Max	Unit
Supply Voltage	Vcc	Measured versus GND	-1		28	V
Storage Temperature	Tstor		-20		85	°C

OPERATING CONDITIONS

Parameter	Symbol	Conditions	Min	Typ	Max	Unit
Supply Voltage	Vcc	Measured versus GND	9		24	V
Supply Current	I	Full ambient temp. range, no output load		22		mA
Thermal Emission Coefficient of Object	ϵ	Adjustable via RS232	10		100	%
Field of View	FOV			±5		°
Digital Output Rate		adjustable	0.1		10	Hz
Digital Output Settings			9600 Baud, 8 Bit, No Parity, 1 Stop Bit			

OPERATING CHARACTERISTICS

Parameter	Symbol	Conditions	Min	Typ	Max	Unit
Object Temperature Range	Tobj		0		300	°C
Ambient Temperature Range	Tamb		0		85	°C
Spectral Sensitivity	S		8		14	µm
Accuracy of Target Temp. Measuring	Acc ₁	Tambient = 25°C	± 1% of Full Scale Range resp. ± 3°C			°C
Accuracy of Target Temp. Measuring	Acc ₂	Full ambient temp. range	± 1.5% of Full Scale Range resp. ± 4.5°C			°C
Resolution Digital	Res		0.3	°C	14	µm
Analog Output Characteristics			T[°C] x 5V/300°C			V
Analog Output Range			0.2 – 4.8			V
Resolution Analog			0.3			°C
Analog Output Source Resistance			40			Ω
Housing			Stainless steel			
Protection class			IP 65			

TPT300V IR Pyrometer

MECHANICAL DIMENSIONS

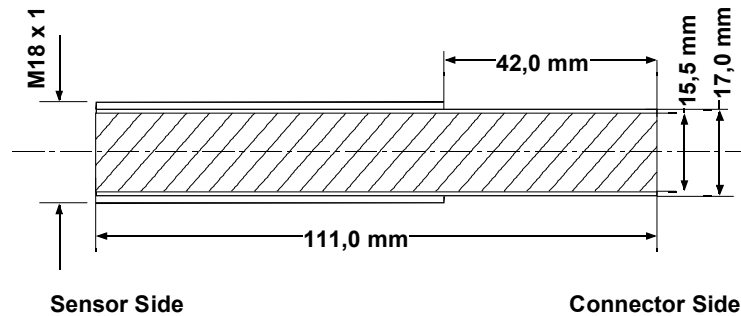

TERMINALS

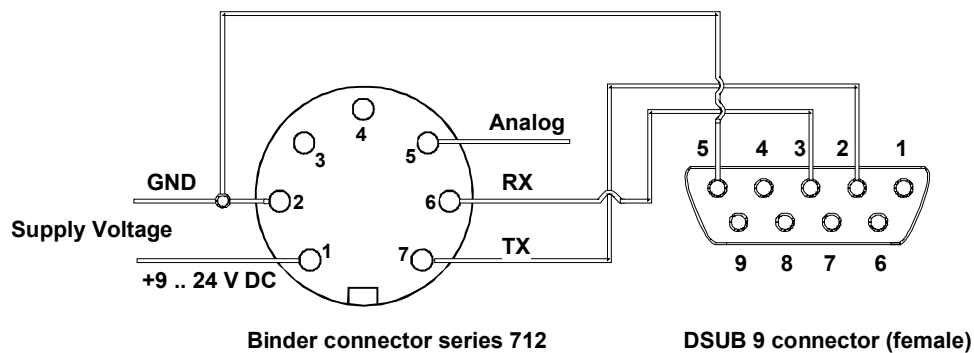

Please take care: pin numbers are marked
on the Binder and on most DSUB connectors!

Pin	Symbol	Description	Typ
1	+VS	Supply Voltage	Supply
2	GND	Ground potential	Supply
3	NC		
4	NC		
5	AN	Analog Output (Voltage)	Analog Output
6	RX	Receive Data (RS232)	Digital Input/Output
7	TX	Transmit Data (RS232)	Digital Input/Output

TPT300V IR Pyrometer

FUNCTION

RS232 PROTOCOL

Fixed RS232 settings: 9600 Baud, 8 Bit, No Parity, 1 Stop Bit

TPT MODES

There are two modes implemented in TPT sensors: the Free Running mode and the On Request mode.

In the Free Running mode the sensor cyclically sends measuring results via RS232. In this mode no further communication (for instance changing sensor parameters) is possible. The only telegram which is accepted in this mode is the "Set On Request Mode" telegram, which stops sensor output.

In On Request mode the sensor only sends data via RS232 after user has sent any request telegram. Only in this mode the changing of sensor parameters is possible.

NOTE: Updating the analog output is directly correlated with updating the RS232 output. Only if output data are sent via RS232 the analog output is updated. Two cases are possible: the "Request Result Data" telegram causes updating serial and analog output and - on the other hand - the cyclically sending data in Free Running Mode.

FACTORY SETTINGS

After delivery following parameters are set:

Parameter	Default Setting
Output Mode	Free Running
Output Format	Object and Ambient Temperature
Output Rate	100ms
Emissivity	98%

TPT300V IR Pyrometer

COMMANDS

command	to the sensor	sensor response	explanation
Request Software Version and Serial Number	„V“	“HL-Planartechnik “ “TPT V2.2 yywwnnn-2” <CR> <LF>	manufacturer company, software version, serial number with yy =Year, ww = week of year, nnn = consecutive number, -2 = product code for TPT300V
Set Output Mode “Free Running”	“F”	“F”	“Free Running” mode is active
Set Output Mode “On Request”	“f”	“f”	“On Request” mode is active
Set Output Format “Object and Ambient Temperature”	“I”	“I”	Format “Object and Ambient Temperature” is active
Set Output Format “Object Temperature”	“i”	“i”	Format “Object Temperature” is active
Set Emissivity Factor	“e” <Emissivity>	“e” <Emissivity>	Emissivity in percentage (10..100), 1 Byte Binary-Format,
Read Emissivity Factor	“E”	“99”	Answer Emissivity in percentage (10..100); ASCII-Format
Request Result Data (While Output Format “Object and Ambient Temperature”)	“R”	“+255:+784” <CR> <LF>	with +255 = sensor temperature in tenth of degree C (1-3 digit with sign) +784 = object temperature in tenth of degree C (1-4 digit with sign);
Request Result Data (While Output Format “Object Temperature”)	“R”	“+784” <CR> <LF>	with +784 = object temperature in tenth of degree C (1-4 digit with sign)
Software Reset	“q”	-	No Echo. It takes about 1 second until software reset is done and sensor acts normal (as after power-up)
Set Output Data Rate for Output Mode “Free Running”	“O” “(Data Rate Code)”	“O” “(Data Rate Code)”	(Note 1), ASCII-Format

“” = ASCII-Format, <> = Binary-Format, <CR>= Carriage Return, <LF> = Line Feed

No reset is necessary to activate the new settings.

Note 1:

Data Rate Code	Output Data Rate
“0”	100 ms
“1”	500 ms
“2”	1000 ms
“3”	5000 ms
“4”	10000 ms

TPT300V IR Pyrometer

CE CONFORMITY

The sensor meets the normative requirements for use in industrial environment. The complete compliance with the norm is given under following conditions:

- Housing is connected to PE by screws
- Meas connecting cable is used
- Shield is connected to GND at user side

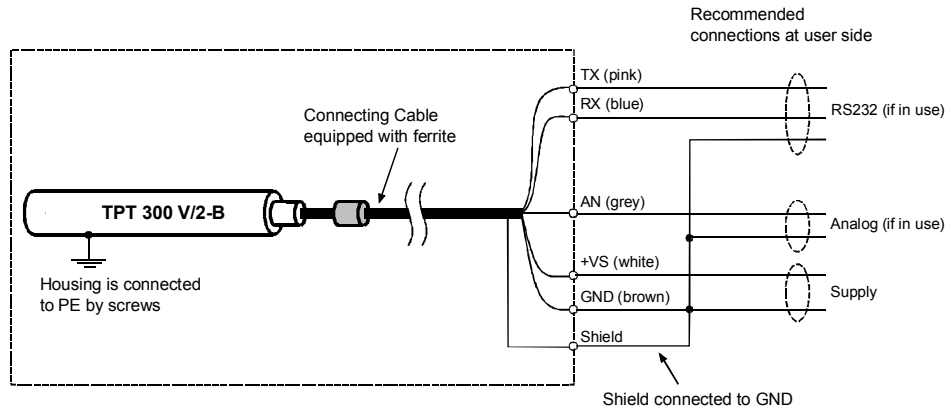

If the user intends to employ his own connecting cable, it is recommended to equip this cable with a ferrite near the sensor. A suitable type is Würth #74271112.

TECHNICAL CONTACT INFORMATION

ORDERING INFORMATION

Part No.	Part Description
G-TPSY-002	TPT300 V

convenient cable on request

NORTH AMERICA	EUROPE	ASIA
Measurement Specialties, Inc. 1000 Lucas Way Hampton, VA 23666 United States Phone: +1-800-745-8008 Fax: +1-757-766-4297 Email: sales@meas-spec.com Web: www.meas-spec.com	MEAS Deutschland GmbH Hauert 13 D-44227 Dortmund Germany Phone: +49-(0)231-9740-0 Fax: +49-(0)231-9740-20 Email: info.de@meas-spec.com Web: www.meas-spec.com	Measurement Specialties China Ltd. No. 26, Langshan Road High-tech Park (North) Nanshan District, Shenzhen 518057 China Phone: +86-755-33305088 Fax: +86-755-33305099 Email: info.cn@meas-spec.com Web: www.meas-spec.com

The information in this sheet has been carefully reviewed and is believed to be accurate; however, no responsibility is assumed for inaccuracies. Furthermore, this information does not convey to the purchaser of such devices any license under the patent rights to the manufacturer. Measurement Specialties, Inc. reserves the right to make changes without further notice to any product herein. Measurement Specialties, Inc. makes no warranty, representation or guarantee regarding the suitability of its product for any particular purpose, nor does Measurement Specialties, Inc. assume any liability arising out of the application or use of any product or circuit and specifically disclaims any and all liability, including without limitation consequential or incidental damages. Typical parameters can and do vary in different applications. All operating parameters must be validated for each customer application by customer's technical experts. Measurement Specialties, Inc. does not convey any license under its patent rights nor the rights of others.